

STAR TREK STARSHIP HANDBOOKS

<http://trek.escape-committee.co.uk>



trek.escape-committee.co.uk



<http://trek.escape-committee.co.uk>

THE STARSHIP HANDBOOK

Compiled by Mark Gill

mark.gill@escape-committee.com

<http://trek.escape-committee.co.uk>

First Edition - Summer 2010 - Version 1.05 (4th May 2014)



[Ex Astris Excellentia](#)

May 2008

Created with Serif PagePlus software.

This ebook was produced purely for reference and fun, on a non-profit, not-for-sale basis.

All copyrights are acknowledged and no infringement is intended.

Star Trek and all photos, symbols and designs copyright Paramount Pictures and CBS Studios Inc. as far as I am aware.

This document © Mark Gill 2004-2014.

INTRODUCTION

I've been waiting for years for someone to produce the definitive book on the starships of Star Trek. So, in 2004, with the wealth of data and images collected by fans on the web, I decided to try put something together myself. This is the result. In this ebook you'll find specs, data and orthographics on over 130 spacecraft from the Star Trek series and movies, culled and collated from around the web.

The project started as a series of individual volumes, each covering nineteen vessels. These PDFs began purely as a personal project so I could print off the schematics I'd come across in a nice, consistent format. The style was inspired by an old World War II fighter planes book I used to have, along with a nod to Adam Lebowitz and Rob Bonchune's excellent Starship Spotter, which is one of my favourite Trek tech manuals. But in 2006 a couple of fellow fans suggested I put them online for others to enjoy too. Since then I've endeavoured to contact and obtain permission from the creators and owners of each schematic and image to use them, and I'm immensely grateful to everyone who's kindly granted that permission. If I've used your image and haven't managed to reach you, or I've not credited you, my apologies - please [contact me](#).

It was always my plan to eventually collate these volumes into one combined, (hopefully!) definitive guide to the major starships of Star Trek, and this is the culmination of that work. All the sources used are credited in the Bibliography (along with the names of the designers of the models and CGI meshes used in the shows themselves). The web links include some of the finest Trek sites out there, and are all well worth checking out, particularly if you'd like to delve further.

With regard to the specs and lists of the vessels included, I wanted to try stick to canon data where possible, or otherwise the most commonly accepted information in fandom (or very occasionally my own preference). Other webmasters have done a tremendous job of creating and adding detailed speculative data themselves, and have done it far better than I would, so I'll leave that extra depth to them.

This project is intended to be a resource and reference for other Trek fans - as well as a showcase for the amazing work of both the talented designers and modellers involved with the Star Trek series, and the artists out there who've created the schematics and renderings. As well as everyone in the Bibliography, I'd like to particularly thank Bernd Schneider, whose starship database was one of the inspirations for this ebook; Graham Kennedy, whose exhaustive specs were an invaluable reference; Doug Drexler and John Eaves, whose blogs have provided a wonderful insight into the background of vessels both well-known and obscure; everyone at Memory Alpha - the ultimate online Star Trek reference; and finally my old friend James Lawson, who's kindly hosted the site and the PDFs since 2007.

This is the Star Trek book I always wanted - I hope you enjoy it too.

Mark Gill

CONTENTS

INTRODUCTION.....	3	EARTH & FEDERATION CIVILIAN	
CONTENTS.....	4	VESSELS.....	93
EARTH & FEDERATION STARFLEET		CLASS III FREIGHTER.....	94
VESSELS.....	7	CONESTOGA.....	96
AERIE CLASS.....	8	DY-100 CLASS.....	98
AKIRA CLASS.....	10	EARTH J CLASS.....	100
AMBASSADOR CLASS.....	12	EARTH Y CLASS.....	102
ATLAS CLASS.....	14	MAQUIS RAIDER.....	104
CENTAUR CLASS.....	16	PHOENIX.....	106
CHALLENGER CLASS.....	18	WHORFIN CLASS.....	108
CHEYENNE CLASS.....	20	KLINGON STARSHIPS.....	111
CONSTELLATION CLASS.....	22	BIRD-OF-PREY (22nd Century).....	112
CONSTITUTION CLASS.....	24	BIRD-OF-PREY (23rd Century).....	114
CONSTITUTION CLASS (Refit).....	26	D4 CLASS.....	116
DAEDALUS CLASS.....	28	D5 CLASS.....	118
DANUBE CLASS.....	30	D7 CLASS.....	120
DEFIANT CLASS.....	32	K'T'INGA CLASS.....	122
EXCELSIOR CLASS.....	34	NEGH'VAR CLASS.....	124
EXCELSIOR CLASS (Refit).....	36	RAPTOR CLASS.....	126
FREEDOM CLASS.....	38	VOR'CHA CLASS.....	128
GALAXY CLASS.....	40	ROMULAN STARSHIPS.....	131
HOLOSHIP.....	42	BIRD-OF-PREY (22nd Century).....	132
ICELAND CLASS.....	44	BIRD-OF-PREY (23rd Century).....	134
INTREPID CLASS.....	46	D'DERIDEX CLASS.....	136
MIRANDA CLASS.....	48	DRONE SHIP.....	138
NEBULA CLASS.....	50	KESTREL CLASS.....	140
NEW ORLEANS CLASS.....	52	MOGAI CLASS.....	142
NIAGARA CLASS.....	54	NEH'VOR CLASS.....	144
NORWAY CLASS.....	56	TERETHI CLASS.....	146
NOVA CLASS.....	58	CARDASSIAN STARSHIPS.....	149
NV CLASS.....	60	GALOR CLASS.....	150
NX CLASS.....	62	GROUMALL CLASS.....	152
NX PROTOTYPE.....	64	HIDEKI CLASS.....	154
OBERTH CLASS.....	66	KELDON CLASS.....	156
OLYMPIC CLASS.....	68	FERENGI STARSHIPS.....	159
PROMETHEUS CLASS.....	70	FERENGI MARAUDER.....	160
PTOLEMY CLASS.....	72	THOLIAN STARSHIPS.....	163
SABER CLASS.....	74	THOLIAN PATROL SHIP.....	164
SALADIN/HERMES CLASS.....	76	THOLIAN WARSHIP.....	166
SHELLEY CLASS.....	78	DOMINION STARSHIPS.....	169
SHERMAN CLASS.....	80	JEM'HADAR ATTACK SHIP.....	170
SOVEREIGN CLASS.....	82	JEM'HADAR BATTLECRUISER.....	172
SOYUZ CLASS.....	84	JEM'HADAR BATTLESHIP.....	174
SPRINGFIELD CLASS.....	86	BREEN WARSHIP.....	176
STEAMRUNNER CLASS.....	88	KAREMMA TRADING VESSEL.....	178
SYDNEY CLASS.....	90		

SON'A BATTLESHIP.....	180	DELTA FLYER.....	268
SON'A COMMAND SHIP.....	182	EXECUTIVE SHUTTLE.....	270
BORG STARSHIPS.....	185	INSPECTION POD.....	272
BORG CUBE.....	186	MISSION SCOUT SHIP.....	274
BORG QUEEN'S SHIP.....	188	PEREGRINE CLASS FIGHTER.....	276
BORG PROBE.....	190	SOVEREIGN CAPTAIN'S YACHT.....	278
BORG SPHERE.....	192	TRAVEL POD.....	280
BORG TACTICAL CUBE.....	194	TYPE 1 SHUTTLEPOD.....	282
BORG TYPE 03.....	196	TYPE 3 SHUTTLECRAFT.....	284
VULCAN STARSHIPS.....	199	TYPE 6 SHUTTLECRAFT.....	286
APOLLO CLASS.....	200	TYPE 7 SHUTTLECRAFT.....	288
D'KYR CLASS.....	202	TYPE 8 SHUTTLECRAFT.....	290
SUUROK CLASS.....	204	TYPE 9 SHUTTLECRAFT.....	292
T'PLANA HATH CLASS.....	206	TYPE 10 SHUTTLECRAFT.....	294
VAHKLAS CLASS.....	208	TYPE 11 SHUTTLECRAFT.....	296
ANDORIAN STARSHIPS.....	211	TYPE 15 SHUTTLEPOD.....	298
KUMARI CLASS.....	212	TYPE 18 SHUTTLEPOD.....	300
SULIBAN STARSHIPS.....	215	WORK BEE.....	302
CELL SHIP (SHORT).....	216	SIZE COMPARISON CHARTS.....	305
CELL SHIP (LONG).....	218	MAJOR STARFLEET VESSELS.....	306
SALVAGE SHIP.....	220	OTHER STARFLEET VESSELS.....	307
STEALTH CRUISER.....	222	ALPHA & BETA QUADRANTS.....	308
XINDI STARSHIPS.....	225	GAMMA & DELTA QUADRANTS.....	309
XINDI-AQUATIC CRUISER.....	226	22nd CENTURY VESSELS.....	310
XINDI-INSECTOID WARSHIP.....	228	AUXILIARY VESSELS.....	311
SPHERE BUILDER POD.....	230	SUPPLEMENTAL.....	312
DELTA QUADRANT STARSHIPS.....	233	BIBLIOGRAPHY.....	313
DEVORE WARSHIP.....	234	BOOKS & WEBSITES.....	314
HIROGEN HUNTER SHIP.....	236	IMAGE SOURCES.....	315
HIROGEN VENATIC CLASS.....	238		
KAZON CARRIER.....	240		
KAZON RAIDER.....	242		
KRENIM WARSHIP.....	244		
MALON EXPORT VESSEL.....	246		
SPECIES 8472 BIOSHIP.....	248		
VIDIIAN CRUISER.....	250		
VIDIIAN INTERCEPTOR.....	252		
VOTH CITY SHIP.....	254		
VOTH RESEARCH VESSEL.....	256		
EARTH & FEDERATION AUXILIARY			
VESSELS.....	259		
AEROSHUTTLE.....	260		
ARGO TRANSPORT SHUTTLE.....	262		
ATAI LONG RANGE SHUTTLE.....	264		
CLASS F SHUTTLECRAFT.....	266		



EARTH & FEDERATION STARFLEET STARSHIPS

AERIE CLASS

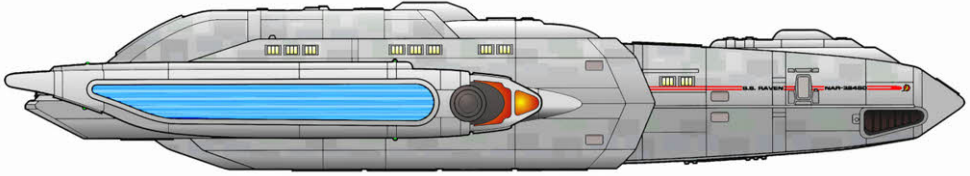

Class: Aerie

Type: Surveyor

Commissioned: 2347

Production Base: Utopia

Planitia Fleet Yards, Mars

Length: 90 metres

Beam: 57.5 metres

Height: 16 metres

Mass: 5,300 metric tons

Crew: 2-10

Cruising Speed: Warp 5

Maximum Speed: Warp 8

Armament: 2 Type VII phaser banks, 1 Mk 22 photon torpedo launcher

NAR Known Ships (SS)

32002 Aerie ϕ

32450 Raven \dagger

\dagger Lost or destroyed

ϕ Non-canon

CLASS INFORMATION:

A deep-space surveyor, the *Aerie*-class was developed by Starfleet at the request of the Federation Science Council. The design filled a niche for a small but well-equipped science vessel which could be loaned out to scientists and research groups for Federation-funded work - avoiding the reassignment of larger ships.

The atmosphere-capable *Aerie* features a Class 4 sensor array mounted on the nose of the ship, with supplementary arrays along the hull. Berthing and storage facilities can be removed in favour of additional laboratories, enabling the ship to be configured for missions of between five and twenty years. The class features eight cargo bay doors on the underside of the hull for easy loading.

One of the first of its class, the S.S. *Raven* NAR-32450 was assigned to Doctors Magnus and Erin Hansen for extended exobiology observation in the Delta Quadrant. The Hansens tracked and studied a Borg cube, but were assimilated in 2356.



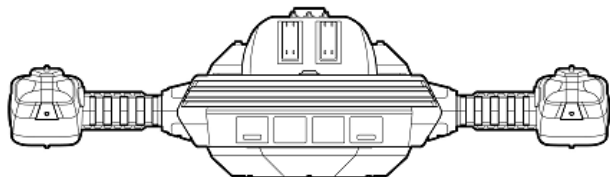
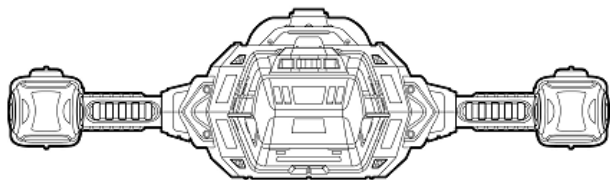
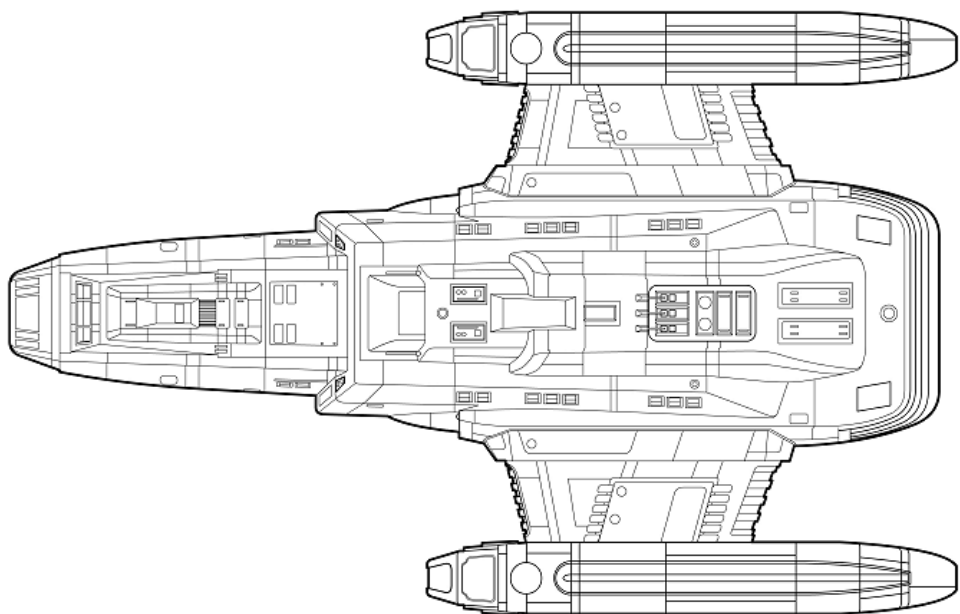
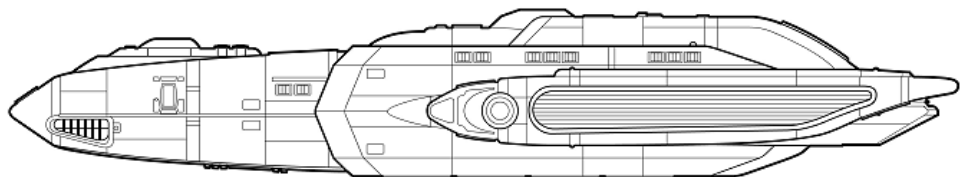

AKIRA CLASS

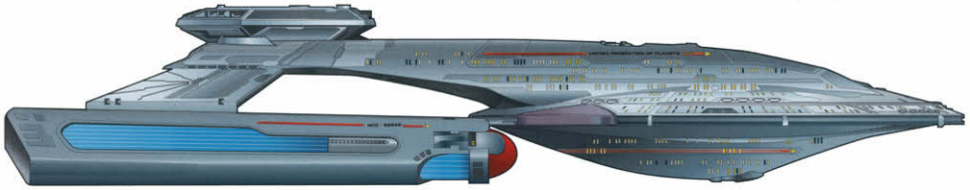

Class: Akira
Type: Heavy Cruiser
Commissioned: 2368
Production Base: Antares & Utopia Planitia Fleet Yards
Length: 440 metres
Beam: 303 metres
Height: 82 metres

Mass: 3,055,000 metric tons
Crew: 500
Cruising Speed: Warp 6
Maximum Speed: Warp 9.8
Armament: 6 Type X phaser arrays, 15 Mk 80 photon torpedo launchers, 2 Mk 80 quantum torpedo launchers

NCC	Known Ships (USS)
62497	Akira
63293	Rabin
65549	Spector
63549	Thunderchild

CLASS INFORMATION:

Designed to supplement tactical support, the *Akira*-class vessel was developed as one of Starfleet's first combat-oriented starships. Initially an R&D design as a testbed for advanced weaponry during the Cardassian War, it was finally commissioned in 2368, a decade after conception, as a response to the growing Borg threat. Effectively a gun boat, the ship features a dedicated weapons pod, housing multiple photon and quantum torpedo tubes, providing formidable strike capability.

As a support ship, the *Akira*-class has three quick pressure shuttle bays: a heavily shielded forward bay for rapid deployment of shuttles or fighters, and two aft bays between the catamarans for protected recovery of small craft.

Akira-class vessels distinguished themselves during the Dominion War, playing vital roles at the Battle of Chin'toka and in Operation Return. They are now a key element of Starfleet's defence forces.



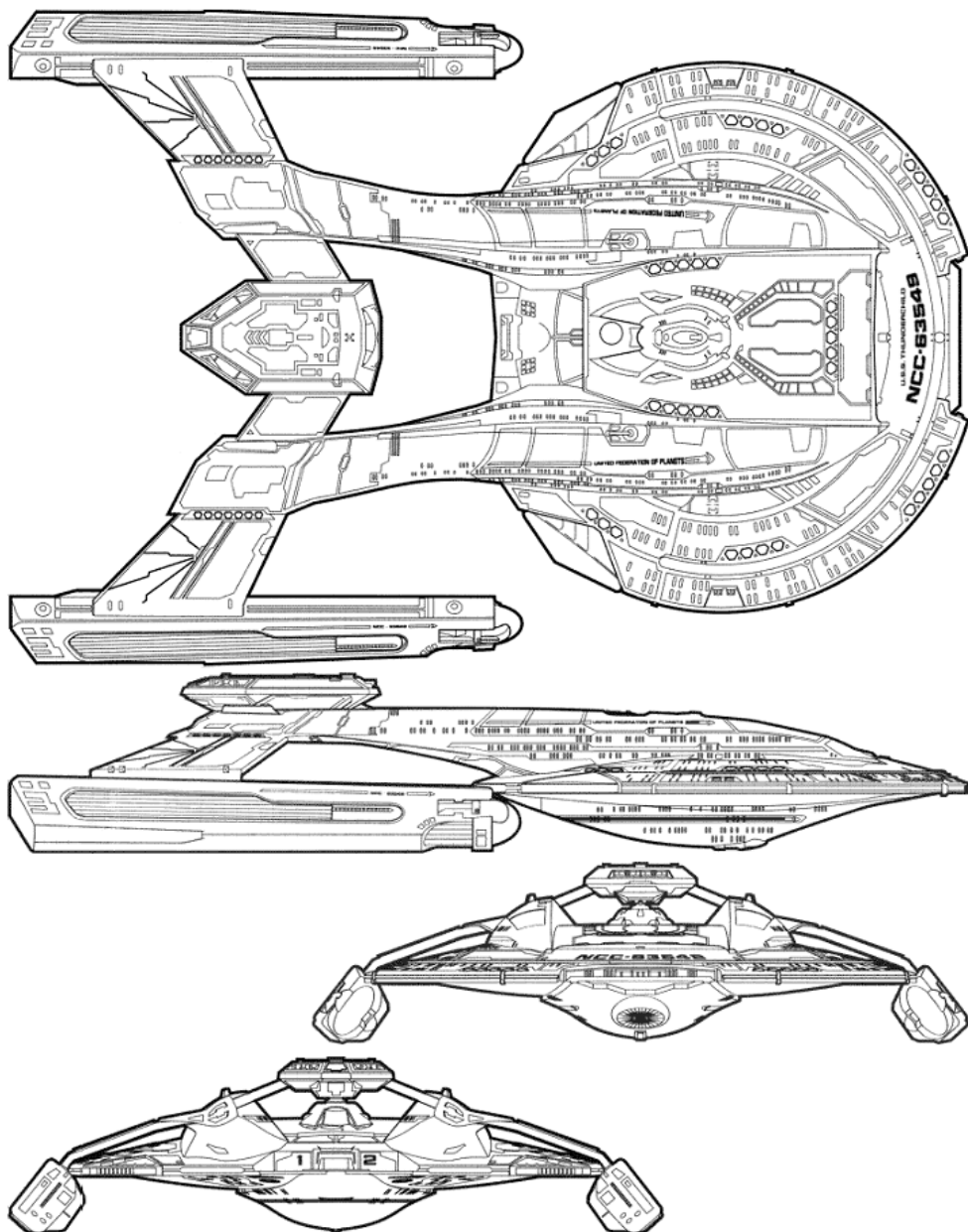

AMBASSADOR CLASS

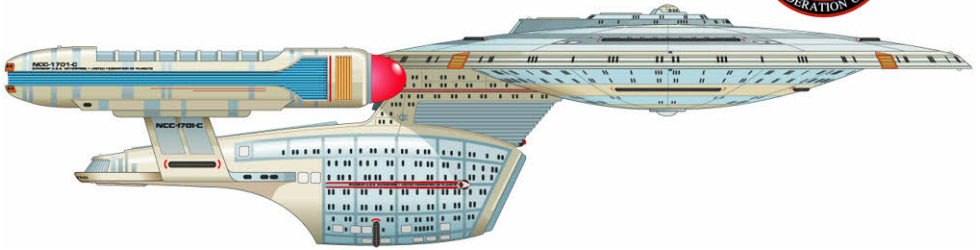
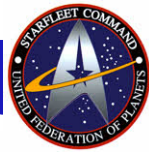

Class: Ambassador

Type: Heavy Cruiser

Commissioned: 2325

Production Base: Utopia Planitia & San Francisco Fleet Yards

Length: 526 metres

Beam: 325 metres

Height: 124 metres

Mass: 3,710,000 metric tons

Crew: 700

Cruising Speed: Warp 6

Maximum Speed: Warp 9

Armament: 11 Type IX phaser arrays, 2 Mk 75 photon torpedo launchers

NCC **Known Ships (USS)**

26849 Adelphi

10521 Ambassador

1701-C Enterprise †

26517 Excalibur *

26531 Exeter

26632 Gandhi

10532 Horatio †

26198 Valdemar

26510 Yamaguchi *†

26136 Zhukov *

* Refit † Lost or destroyed

CLASS INFORMATION:

Developed as a complement to the *Excelsior*-class, the *Ambassador*-class was Starfleet's primary instrument of exploration during the second quarter of the 24th century. The *Ambassador* was the first vessel to employ triple-redundant electro-plasma system (EPS) taps and collimated phaser arrays, laid on the hull in strips rather than in banks.

Several of the second run of *Ambassador*-class vessels were built to an improved specification, including structural improvements and enlarged shuttle bay facilities.

The *Ambassador*-class served with distinction during the Cardassian War, but the introduction of the *Galaxy*-class from 2357 saw the *Ambassadors* relegated to more routine work, and only a relatively small number remain in service.

Famous vessels of the class include the *U.S.S. Enterprise* NCC-1701-C, launched in 2332 and destroyed at Narendra III in 2344, and the *U.S.S. Excalibur* NCC-26517.



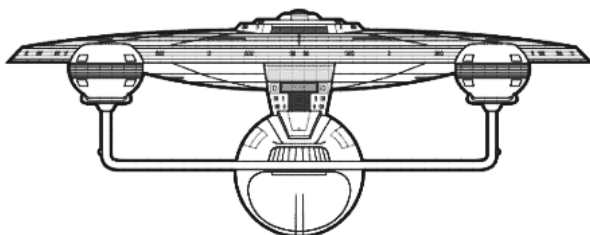
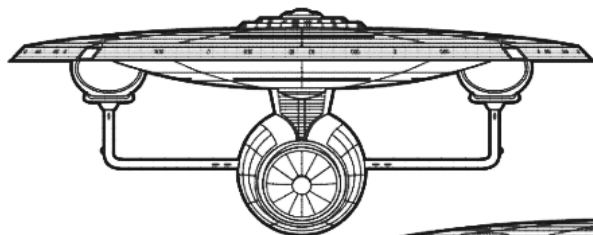
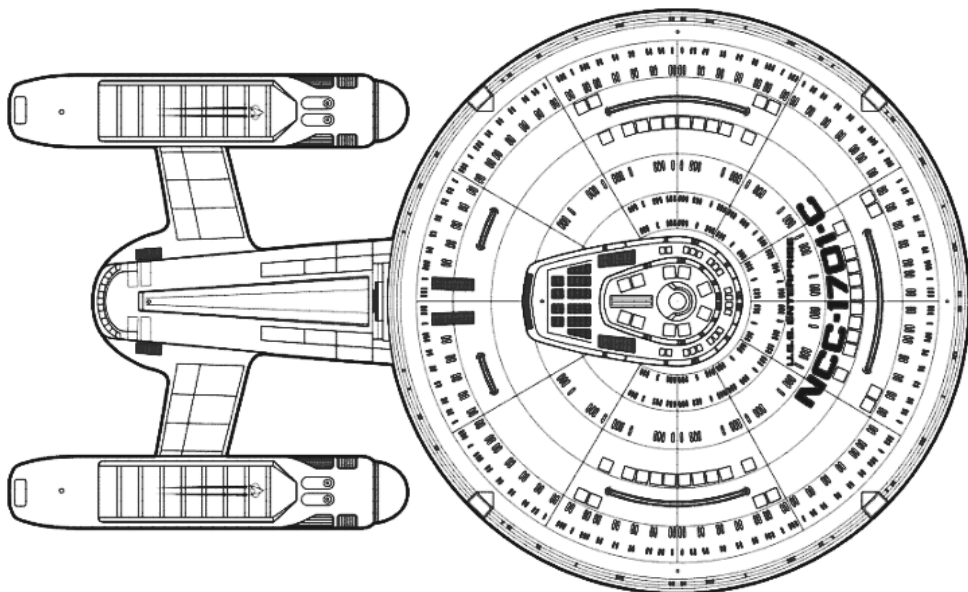
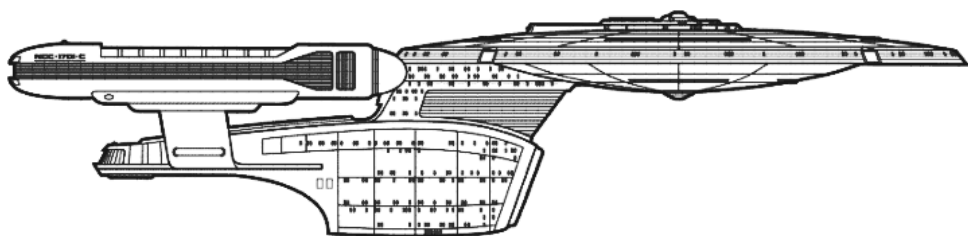

ATLAS CLASS

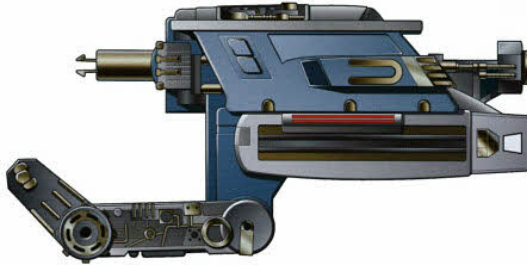

Class: Atlas
Type: Tug
Commissioned: 2370
Production Base: Various
Length: 66 metres
Beam: 54.5 metres
Height: 33 metres
Mass: 7,800 metric tons

Crew: 0
Cruising Speed: Warp 3
Maximum Speed: Warp 4
Armament: None

NCC **Known Ships (USS)**
Ertl

CLASS INFORMATION:

The *Atlas*-class tug was a type of specialized Federation starship used exclusively for towing damaged or disabled vessels.

The compact and utilitarian design incorporated two small nacelles on either side of the main hull, and a pair of powerful tractor emitters mounted on twin pylons which trailed behind the craft. The tug could be automated or operated remotely, requiring no flight crew, but was capable of towing ships of at least the size of an *Excelsior*-class starship.

During the Dominion War *Atlas*-class tugs were utilized in the evacuation of disabled vessels from battle zones. The *U.S.S. Fredrickson* NCC-42111 was one starship to benefit from these utility vessels in 2374.



drex files

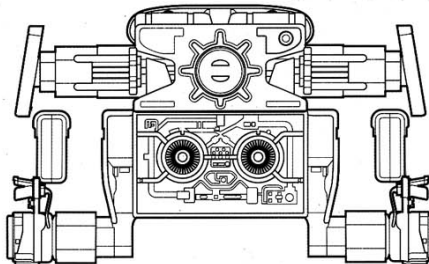
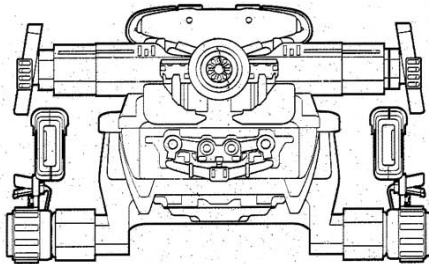
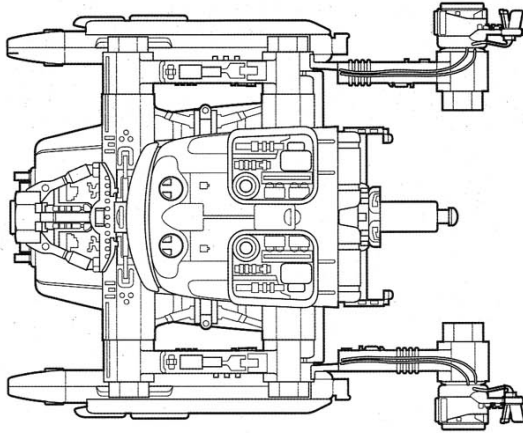
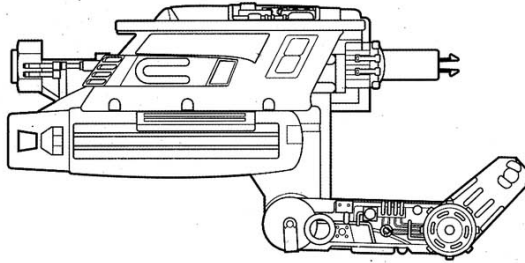

CENTAUR CLASS

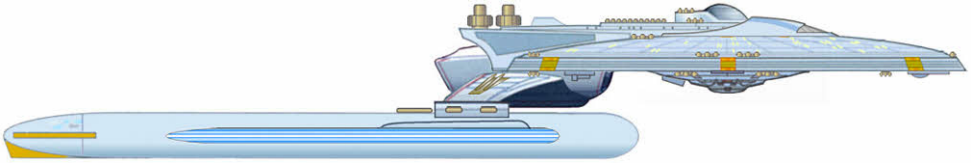

Class: Centaur
Type: Medium Cruiser
Commissioned: 2325
Production Base: Utopia Planitia Fleet Yards, Mars
Length: 210 metres
Beam: 116 metres
Height: 36 metres

Mass: 145,000 metric tons
Crew: 52
Cruising Speed: Warp 6
Maximum Speed: Warp 9.6
Armament: 9 Type VIII phaser banks, 4 Mk 22 photon torpedo launchers

NCC	Known Ships (USS)
42043	Buckner Centaur

CLASS INFORMATION:

The *Centaur*-class was developed as a companion to the larger *Excelsior*-class vessels in the early 24th century. The design features an *Excelsior*-style primary hull with a shuttlebay just forward of the bridge. It also has a weapons pod, similar to that of the *Miranda*, at the bottom of the saucer between the warp nacelles. The *Centaur* is designated as a medium cruiser but frequently functions as a scout.

The lead ship of the class - the *U.S.S. Centaur* NCC-42043 - was commanded by Captain Charles Reynolds. In 2374 the *Centaur* encountered a Jem'Hadar attack ship commanded by Captain Benjamin Sisko and his crew on a secret mission deep inside Cardassian space. Not knowing that the ship was piloted by a Starfleet crew, Reynolds engaged and damaged it before being fought off. The *Centaur* served with distinction during the Dominion War.



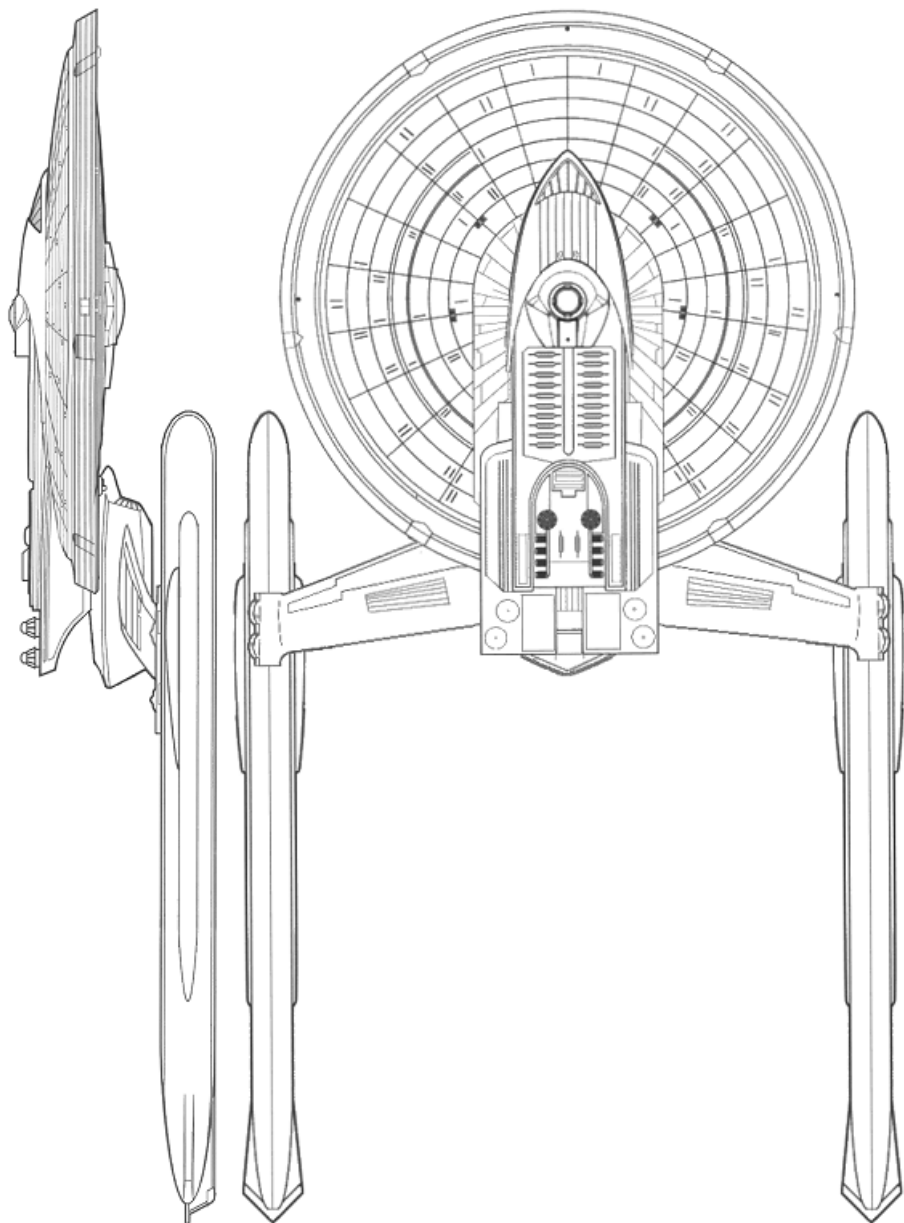

CHALLENGER CLASS

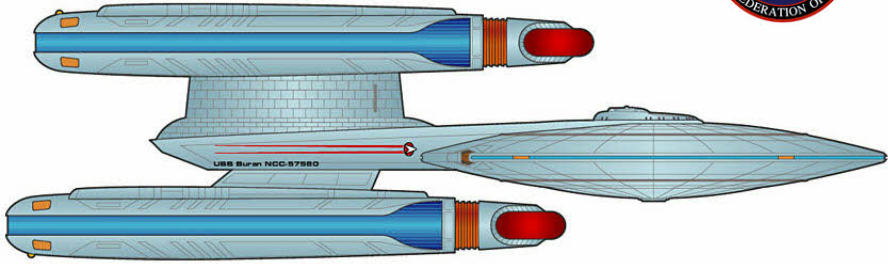

Class: Challenger

Type: Light Cruiser

Commissioned: 2344

Production Base: Copernicus

Ship Yards, Luna

Length: 392 metres

Beam: 265 metres

Height: 114 metres

Mass: 1,900,000 metric tons

Crew: 300

Cruising Speed: Warp 6

Maximum Speed: Warp 9.2

Armament: 3 Type IX phaser arrays, 2 Mk 75 photon torpedo launchers

NCC **Known Ships (USS)**

57537 Armstrong

57580 Buran †

57566 Challenger

57566 Kearsarge

† *Lost or destroyed*

CLASS INFORMATION:

The *Challenger*-class is a light cruiser related to the *Galaxy*-class starship family and utilises the same saucer and warp nacelles as the *New Orleans*-class frigate.

Utilizing two vertically arranged nacelles, the *Challenger* perpetuates an older design lineage not seen for some time on Federation ships. While the vertical nacelle configuration doesn't yield a major benefit, the vessel's centre of gravity does make manoeuvrability more solid and robust at impulse speed, particularly during atmospheric flight. However problems with warp field balance and the antimatter containment ejection system during trials meant only four were built.

Notable ships of the *Challenger*-class include the *U.S.S. Buran* NCC-57580 which was destroyed by the Borg at the Battle of Wolf 359, and the *U.S.S. Armstrong* NCC-57537 which was ambushed by a Klingon battle group in 2373.

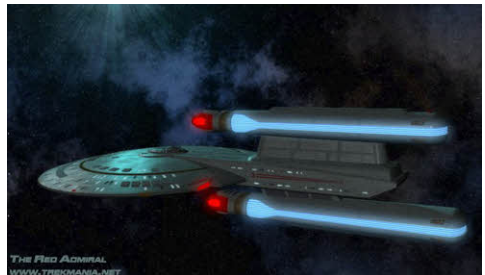

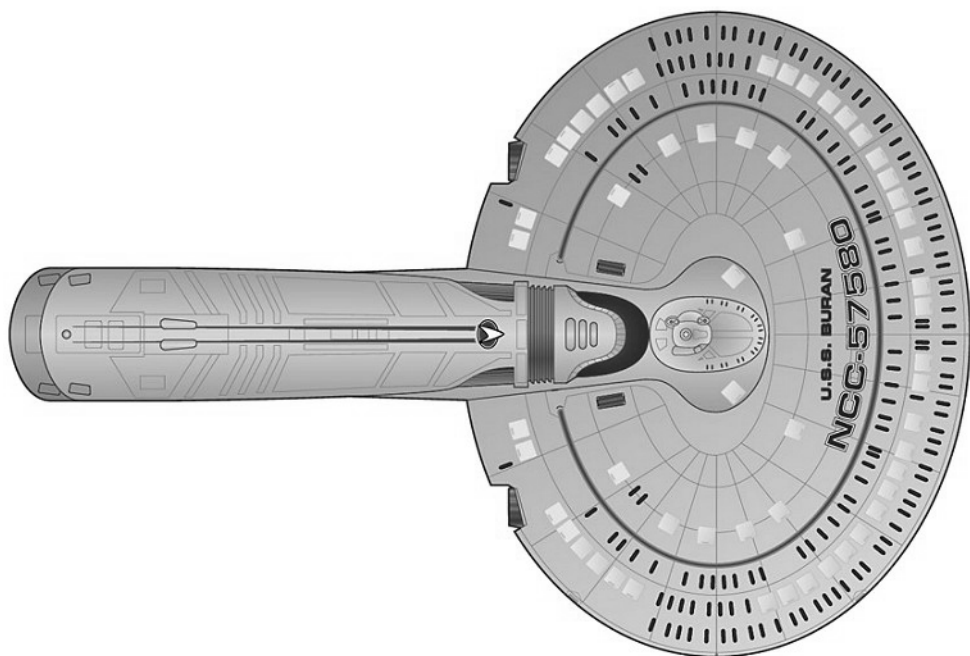
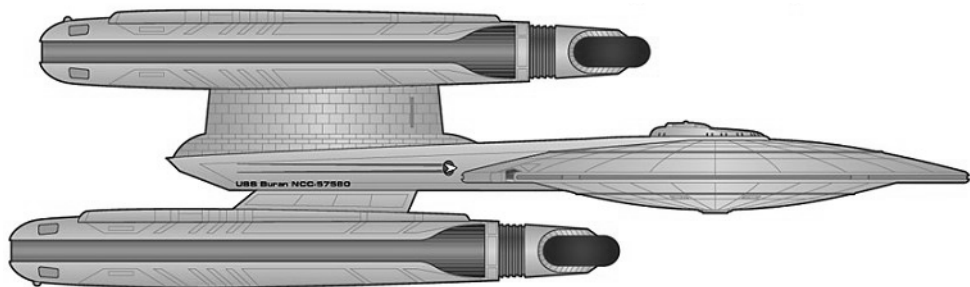

CHEYENNE CLASS

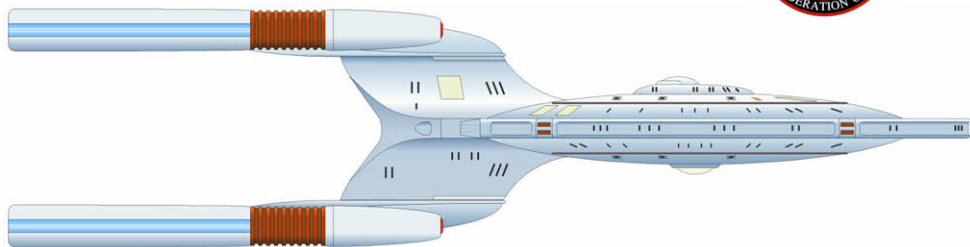

Class: Cheyenne
Type: Medium Cruiser

Commissioned: 2352

Production Base: Utopia Planitia & San Francisco Fleet Yards

Length: 366 metres

Beam: 265 metres

Height: 90 metres

Mass: 1,900,000 metric tons

Crew: 245

Cruising Speed: Warp 7

Maximum Speed: Warp 9.4

Armament: 6 Type IX phaser arrays, 2 Mk 75 photon torpedo launchers

NCC	Known Ships (USS)
71620	Ahwahnee
	Cheyenne

CLASS INFORMATION:

The *Cheyenne*-class was conceived as Starfleet's replacement for the aging *Constellation*-class and is part of the *Galaxy*-class family of starships. Like its predecessor, the *Cheyenne*'s four-nacelle configuration makes it ideal for long-range exploration missions as well as providing extra power for defensive patrol duties.

Like the *Galaxy*-class, the *Cheyenne* was one of the first Starfleet vessels to be equipped with holodecks and recreational facilities designed with families in mind.

The most famous *Cheyenne*-class starship is the *U.S.S. Ahwahnee* NCC-71620 which fought the Borg at Wolf 359 in 2367 and took part in the blockade of Romulan ships supplying the Duras family's forces in the Klingon Civil War of 2368.

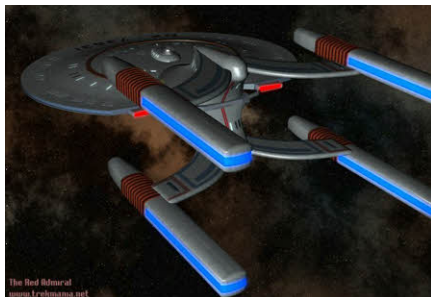

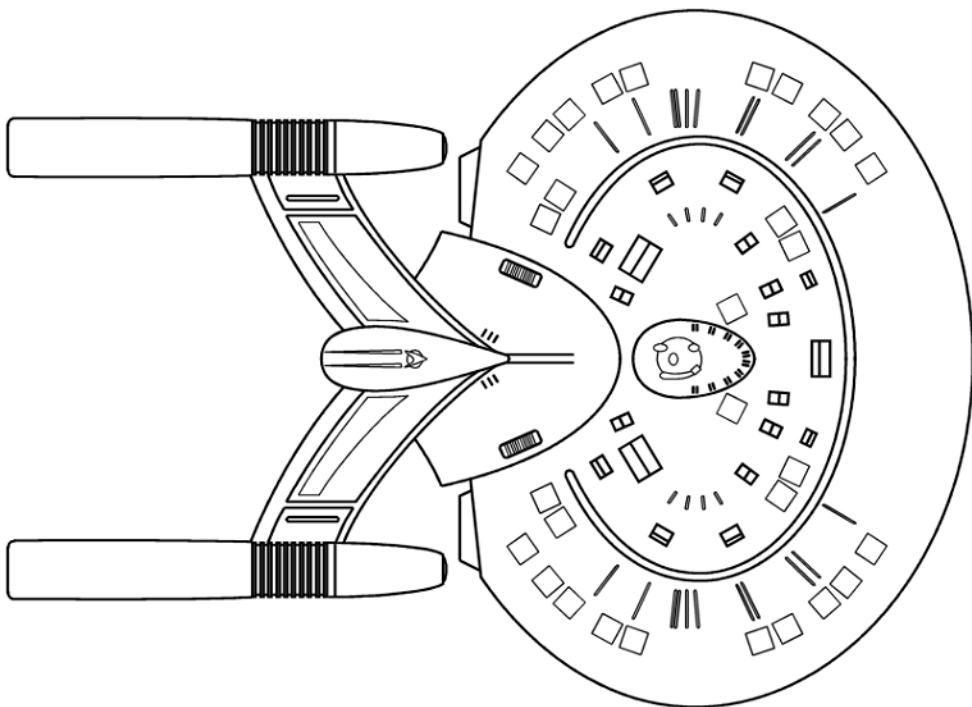
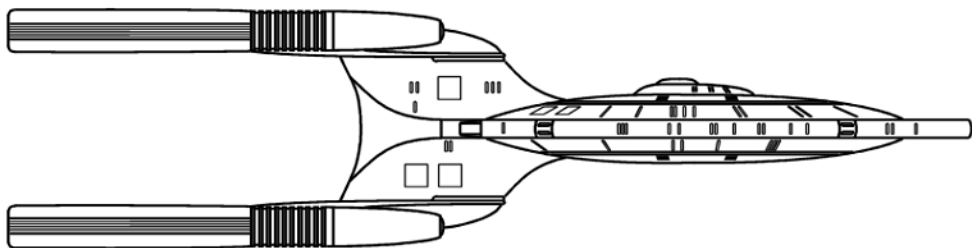

CONSTELLATION CLASS

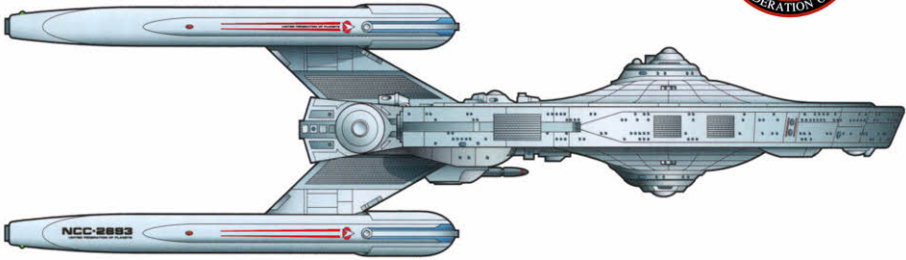

Class: Constellation
Type: Medium Cruiser
Commissioned: 2284
Production Base: Copernicus Ship Yards, Luna
Length: 310 metres
Beam: 175 metres
Height: 86 metres

Mass: 325,000 metric tons
Crew: 535
Cruising Speed: Warp 6
Maximum Speed: Warp 9
Armament: 6 Type VII phaser banks, 2 pulse phaser cannons, 4 Mk 70 photon torpedo launchers

NCC	Known Ships (USS)
1974	Constellation
3890	Gettysburg
9761	Gihlan
2593	Hathaway
3069	Magellan
2893	Stargazer †
2590	Valkyrie
9754	Victory

† Lost (later recovered)

CLASS INFORMATION:

First commissioned in 2284, the *Constellation*-class was developed to complement and eventually replace the similar-sized *Constitution*-class vessels in deep-space exploration duties.

The four warp nacelle configuration favoured long-range missions as well as providing extra power for defensive patrol duties.

The most famous *Constellation*-class vessel was the *U.S.S. Stargazer* NCC-2893, the first command of Captain Jean-Luc Picard, who after a field-promotion in 2333 became Starfleet's youngest ever captain.

Only a handful of *Constellation*-class vessels remain in service, and are now mostly used for courier and transportation duties within the core worlds of the Federation.



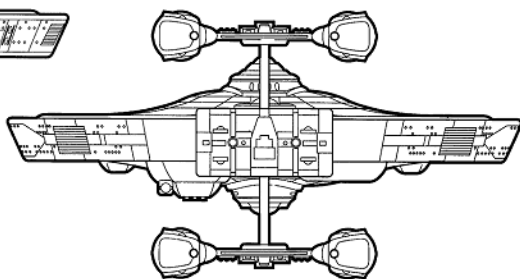
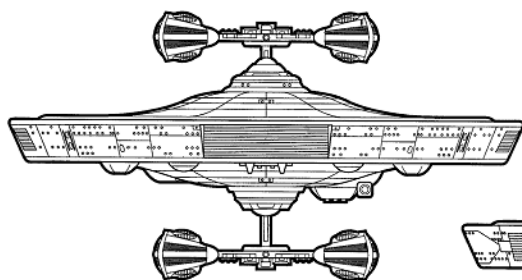
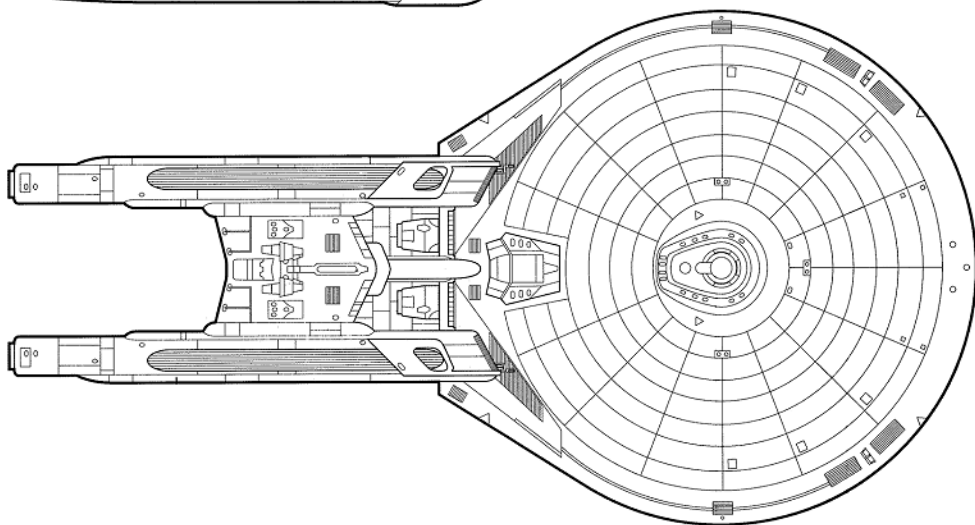
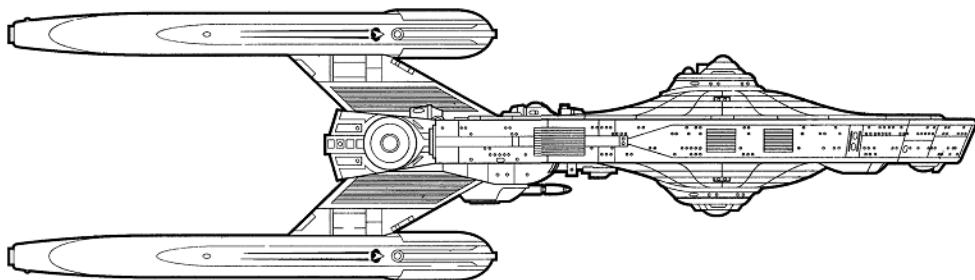

CONSTITUTION CLASS

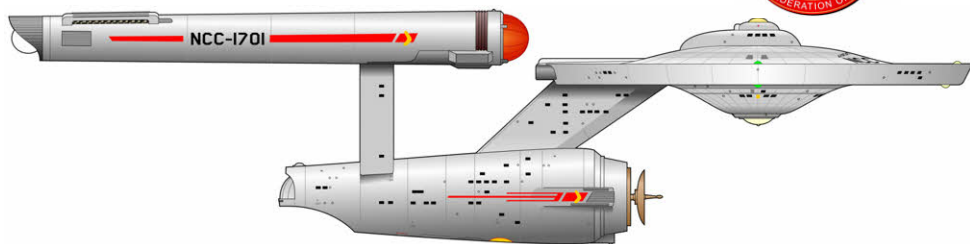

Class: Constitution
Type: Heavy Cruiser

Commissioned: 2245

Production Base: San Francisco Yards & Tranquility Base

Length: 288.6 metres

Beam: 127.1 metres

Height: 72.6 metres

Mass: 190,000 metric tons

Crew: 430

Cruising Speed: Warp 6 *

Maximum Speed: Warp 8 *

Armament: 4 Phaser banks, 2 Mk 12 photon torpedo launchers

* *Original Cochrane Unit (OCU)*

NCC Known Ships (USS)

1017	Constellation †
1700	Constitution
1764	Defiant †
956	Eagle
1895	Endeavour
1701	Enterprise †
1697	Essex
1664	Excalibur
1672	Exeter
1647	Farragut †
1703	Hood
1631	Intrepid †
1710	Kongo
1709	Lexington
1715	Merrimac
1657	Potemkin
1371	Republic
1717	Yorktown

† *Lost or destroyed*

CLASS INFORMATION:

First commissioned in 2245, the *Constitution*-class was the largest and most powerful starship design of its day.

Built for a wide range of missions from long-range exploration and scientific surveys to patrol and defence duties, the *Constitution* featured fourteen science labs, a large hangar bay, and a then-formidable arsenal.

Twelve ships of what was originally called *Starship Class* were initially constructed. The most famous was the *U.S.S. Enterprise* NCC-1701, whose five-year mission under Captain James T. Kirk has passed into legend. So successful were the *Enterprise's* exploits that the ship's insignia was subsequently adopted by the whole of Starfleet. The *Enterprise* was the first of its class to be refitted in the 2270s.

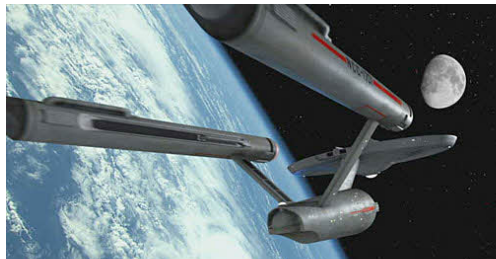

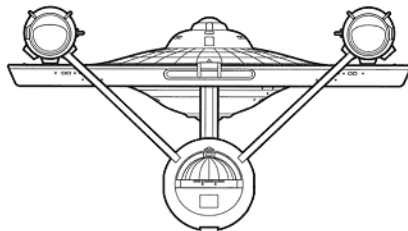
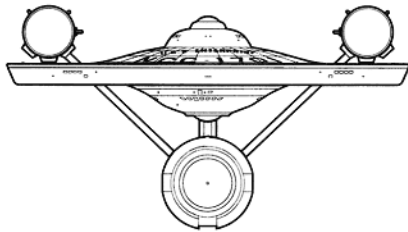
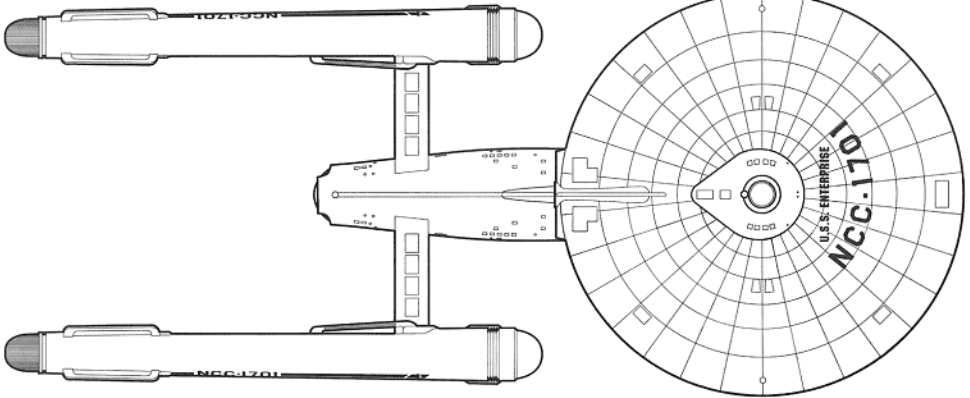
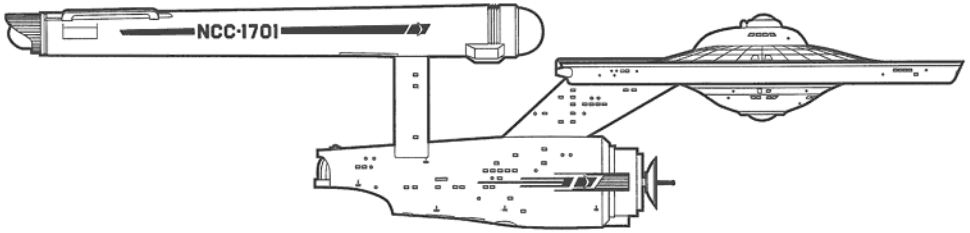

CONSTITUTION CLASS (Refit)

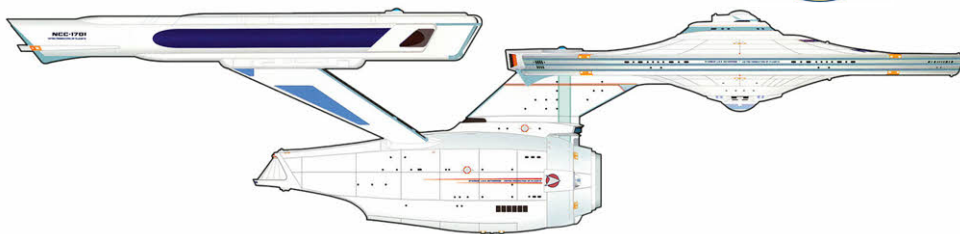

Class: Constitution (Refit)

Type: Heavy Cruiser

Commissioned: 2273

Production Base: San Francisco Fleet Yards, Earth

Length: 304.8 metres

Beam: 141.7 metres

Height: 71.3 metres

Mass: 210,000 metric tons

Crew: 500

Cruising Speed: Warp 8 *

Maximum Speed: Warp 12 *

Armament: 12 Type VII phaser banks, 2 Mk 6 photon torpedo launchers

* *Original Cochrane Unit (OCU)*

NCC **Known Ships (USS)**

2048 Ahwahnee

1700 Constitution

956 Eagle

1895 Endeavour

1701 Enterprise †

1701-A Enterprise

1697 Essex

1664 Excalibur

1672 Exeter

1703 Hood

1707 Intrepid

1732 John Muir

1710 Kongo

1709 Lexington

1715 Merrimac

1657 Potemkin

1371 Republic

1717 Yorktown

† *Lost or destroyed*

CLASS INFORMATION:

The original *Constitution*-class configuration was first commissioned in 2245. Subsequent advancements in technology were incorporated into a major redesign a quarter of a century later. The first refit vessel, the legendary *U.S.S. Enterprise* NCC-1701, was rushed back into service in 2273 to intercept the V'Ger probe.

The class was the first to feature linear warp drive, as well as upgraded transporters and computer systems which helped it continue in its role as Starfleet's leading exploration, research and defence tool for the remainder of the 23rd century.

The *U.S.S. Enterprise* NCC-1701-A was also a *Constitution*-class vessel. She and her crew helped pave the way for Klingon and Federation cooperation at the signing of the Khitomer Accords in 2293.



Plans CONSTITUTION CLASS (Refit)

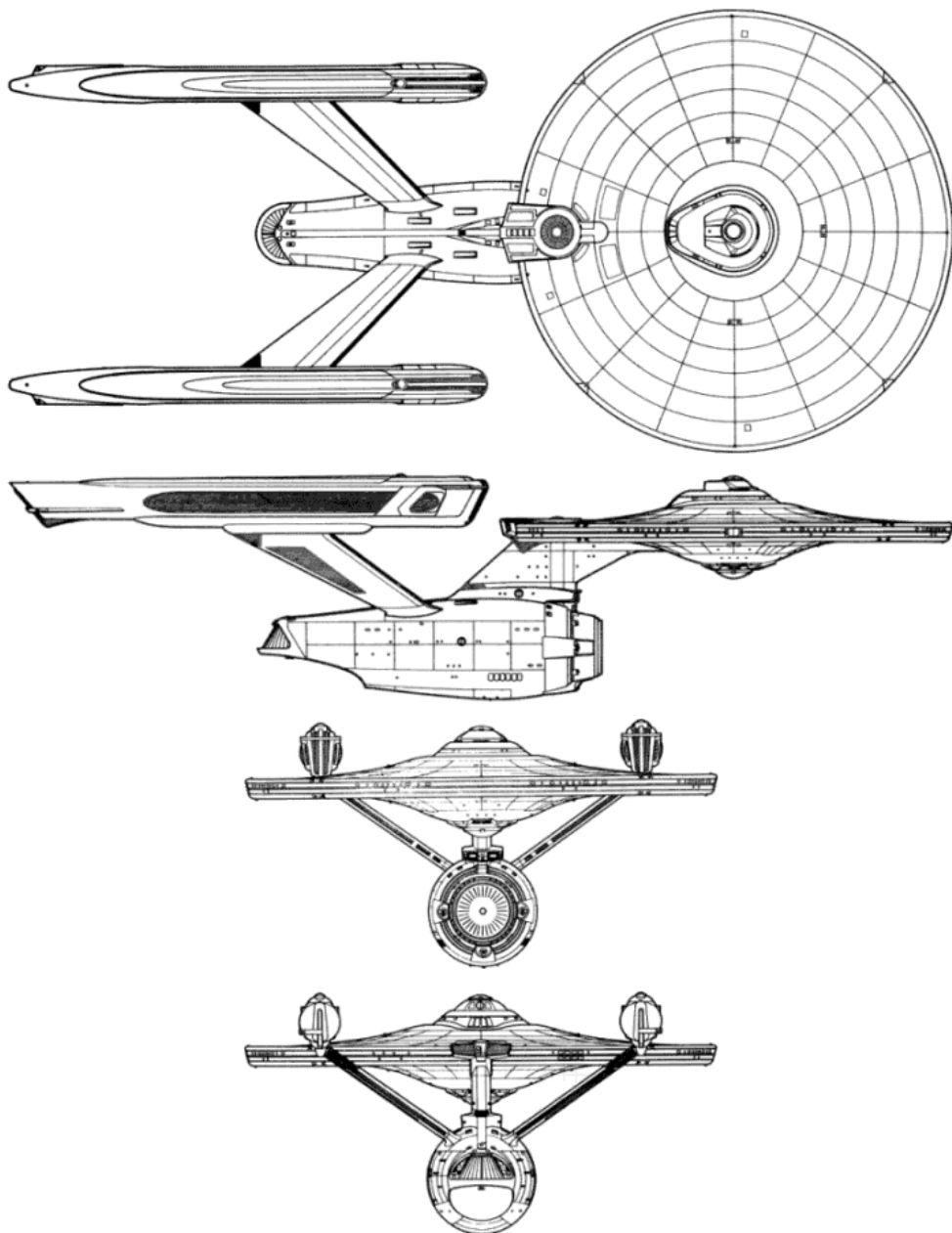

DAEDALUS CLASS

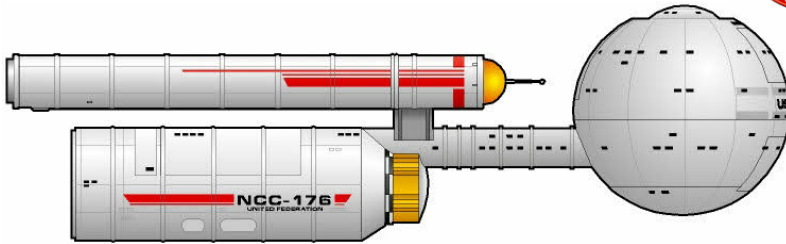

Class: Daedalus

Type: Cruiser

Commissioned: 2161

Production Base: Utopia
Planitia Fleet Yards, Mars

Length: 105 metres

Beam: 48 metres

Height: 31 metres

Mass: 92,000 metric tons

Cruising Speed: Warp 5 *

Maximum Speed: Warp 7 *

Crew: 229

Armament: 3 Phase cannons, 2
photonic torpedo launchers

* *Original Cochrane Unit (OCU)*

NCC **Known Ships (USS)**

189 Archon †

160 Carolina

129 Daedalus

173 Essex †

176 Horizon †

430 Lovell †

† *Lost or destroyed*

‡ *Non-canon*

CLASS INFORMATION:

The *Daedalus*-class was one of the first deep-space starship designs commissioned and operated under the auspices of the United Federation of Planets through the second half of the 22nd century. The last ships of this class were taken out of service by the year 2196.

The *Daedalus*-class was among the first to demonstrate the primary/secondary hull and warp nacelle configurations that would become characteristic of many Starfleet vessels. This design pioneered the spherical primary hull configuration used by the *Olympic*-class nearly two centuries later.

Famous ships of the class include the *U.S.S. Archon* NCC-189, whose crew were assimilated by the computer Landru at Beta III in 2167, and the *U.S.S. Horizon* NCC-176, destroyed at Sigma Iotia II the following year.

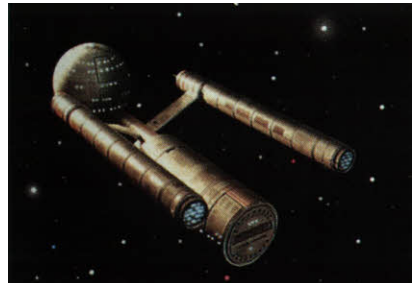
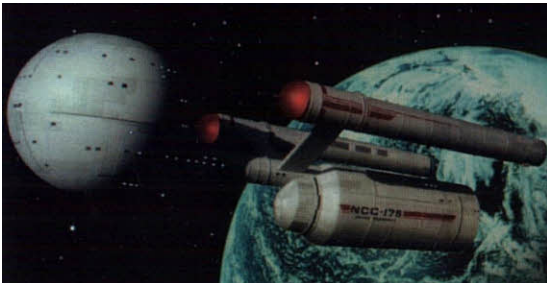

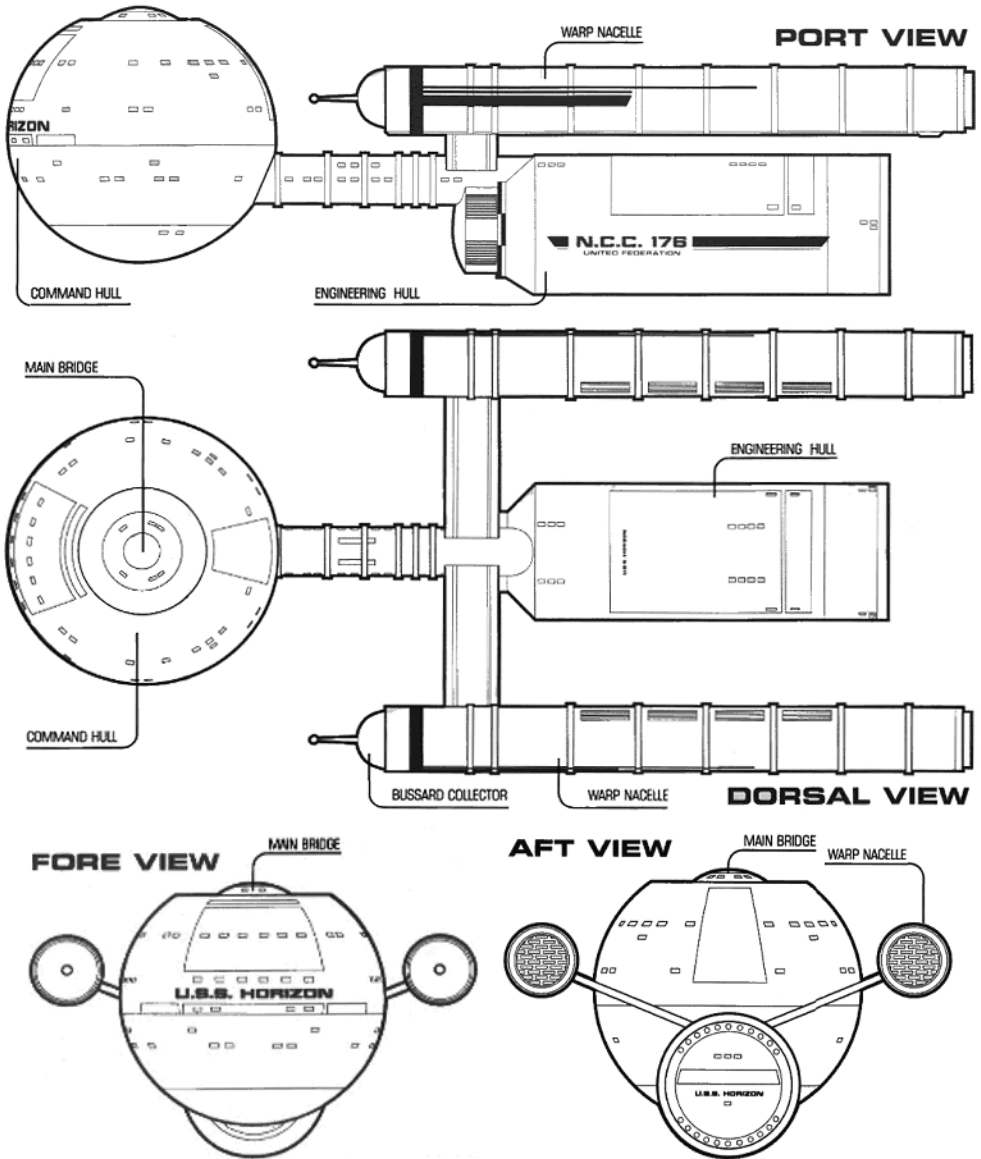

DANUBE CLASS

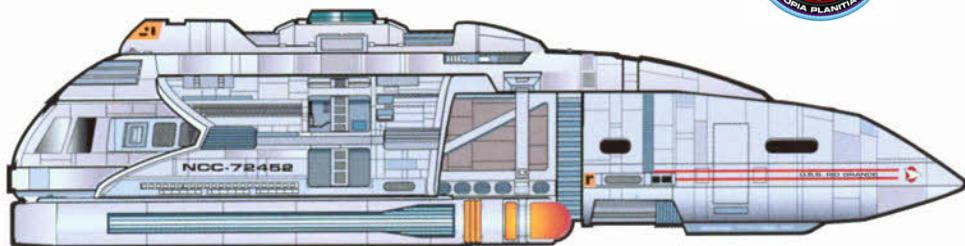

Class: Danube

Type: Runabout

Commissioned: 2368

Production Base: Utopia
Planitia Fleet Yards & others

Length: 23.1 metres

Beam: 13.7 metres

Height: 5.4 metres

Mass: 158.7 metric tons

Crew: 2-4

Cruising Speed: Warp 4

Maximum Speed: Warp 8.3

Armament: 6 Type VI phaser
arrays, 2 Mk 25 photon micro-
torpedo launchers

NCC **Known Ships (USS)**

72003 Danube

72311 Gander †

72454 Ganges †

72617 Mekong †

72905 Orinoco †

72452 Rio Grande

72936 Rubicon †

73024 Shenandoah †

73196 Volga

72453 Yangtze Kiang †

74602 Yukon †

73918 (Name unknown)

† *Lost or destroyed*

CLASS INFORMATION:

A small, versatile vessel for short-term support missions, the *Danube*-class runabout features an interchangeable midsection allowing the ship to be customised for a variety of uses. A mission-specific equipment pod containing torpedoes or sensors can also be attached amidships.

Aft of the detachable (in emergency) cockpit section and labs the runabout features a small living area for extended missions.

Entering service in 2368 immediately after successful trials, the first three runabouts were assigned to space station *Deep Space Nine*, though of these only the U.S.S. *Rio Grande* NCC-72454 remains in service.



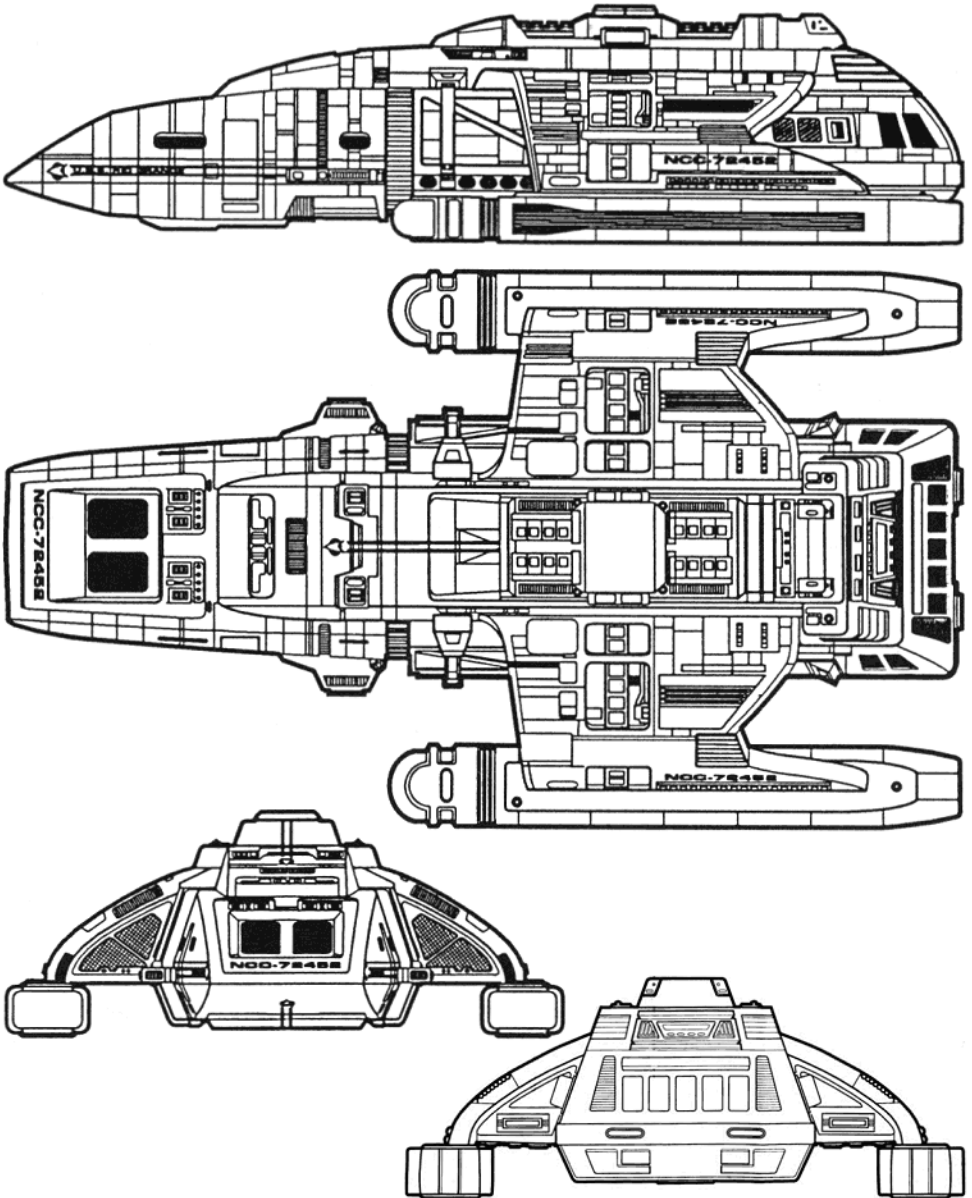

DEFIANT CLASS

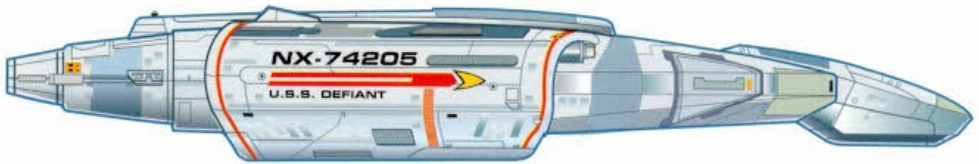

Class: Defiant

Type: Escort

Commissioned: 2370

Production Base: Antares & Utopia Planitia Fleet Yards

Length: 119.5 metres

Beam: 90.3 metres

Height: 25.5 metres

Mass: 355,000 metric tons

Crew: 40

Cruising Speed: Warp 6

Maximum Speed: Warp 9.982

Armament: 4 Type XII pulse phaser cannons, 2 Type X phaser arrays, 4 Mk 75 photon/quantum torpedo launchers

NCC Known Ships (USS)

74205 Defiant †

75633 Sao Paulo *

74210 Valiant †

75418 Valiant

* Renamed Defiant

† Lost or destroyed

CLASS INFORMATION:

Originally developed as Starfleet's 'Borg-buster' - a pure warship - the *Defiant* was a testbed for cutting-edge technology.

The class features compact, protected warp nacelles, pulse phaser cannons, quantum torpedoes and ablative armour. First commissioned in 2370, the prototype *U.S.S. Defiant NX-74205* also carried a Romulan cloaking device as part of its subsequent role defending *Deep Space Nine* from Dominion attack.

The *Defiant* has a compact warp core capable of powering a starship four times its size, which initially could not be run at full output due to structural stresses. Field testing by the crew of *DS9* ironed out this and other initial flaws, and the *Defiant*-class was put into production ahead of full hostilities with the Dominion.

The original *U.S.S. Defiant* was destroyed by the Breen in 2375. It was replaced by the *U.S.S. Sao Paulo* NCC-75633 which was renamed *Defiant* by Starfleet.



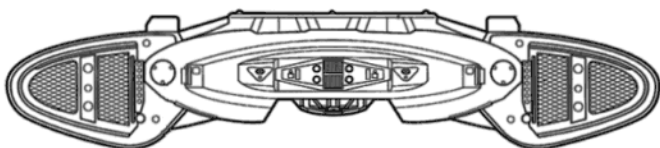
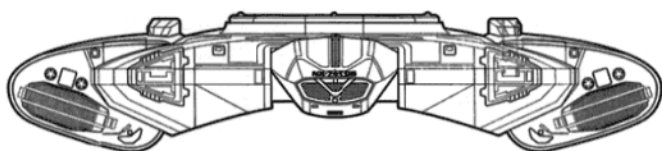
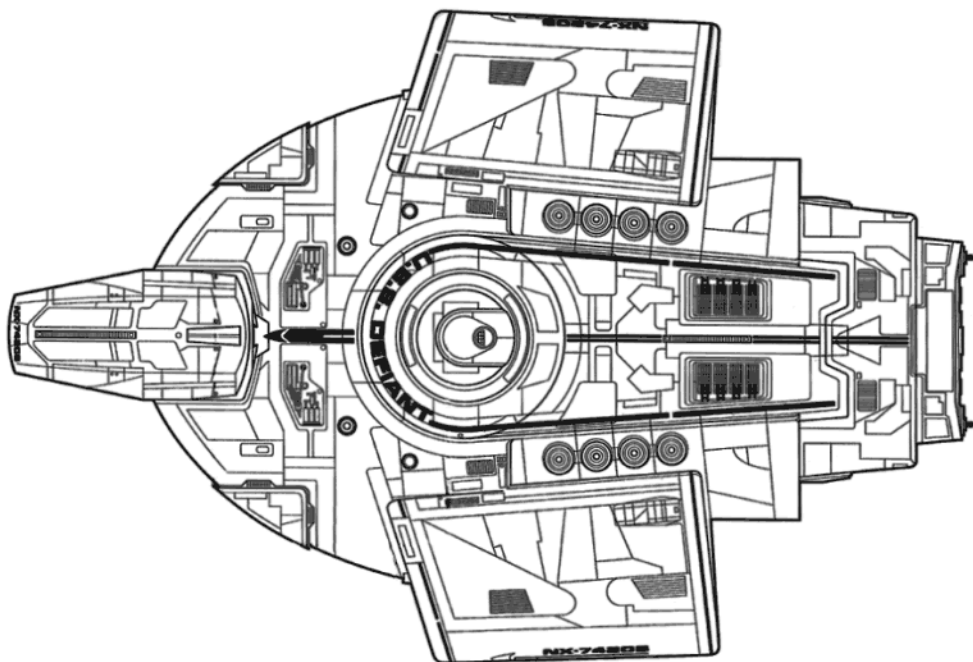
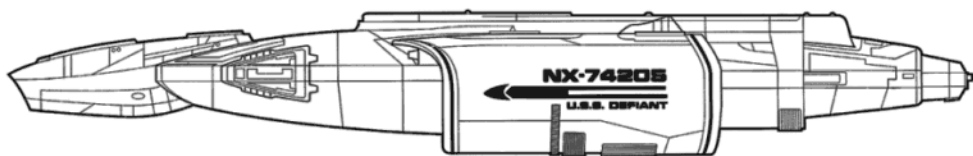

EXCELSIOR CLASS

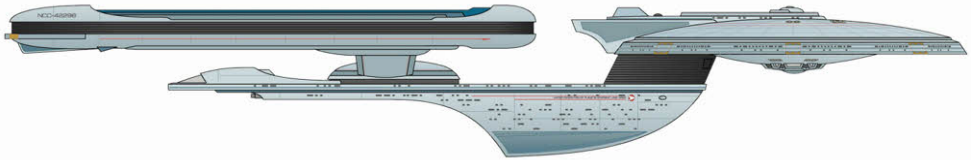

Class: Excelsior

Type: Explorer

Commissioned: 2284

Production Base: Utopia Planitia & San Francisco Fleet Yards

Length: 467 metres

Beam: 186 metres

Height: 78 metres

Mass: 2,350,000 metric tons

Crew: 750

Cruising Speed: Warp 8

Maximum Speed: Warp 9.5

Armament: 16 Type VIII phaser banks, 4 Mk 70 photon torpedo launchers

NCC Known Ships (USS)

42995	Al-Batani
14232	Berlin
42136	Cairo †
2032	Challenger
42285	Charleston
50446	Crazy Horse
38955	Crockett
1701-B	Enterprise *
2000	Excelsior
2582	Farragut
14598	Fearless
42111	Frederickson
40512	Gorkon
42857	Grissom †
42296	Hood
38907	Intrepid
42768	Lakota *
14427	Lexington †
34099	Livingston
38997	Malinche
62043	Melbourne †
13958	Okinawa
18253	Potemkin
2544	Repulse
2573	Roosevelt †
14934	Tecumseh
43305	Valley Forge
* Refit † Lost or destroyed	

CLASS INFORMATION:

Launched in 2284, the *U.S.S. Excelsior* NX-2000 was initially fitted with an experimental transwarp drive. 'The Great Experiment', as it was dubbed, was a failure, but the promising spaceframe was refitted with a standard warp drive and became the blueprint for one of Starfleet's most enduring and successful starship designs.

The *Excelsior*-class was produced for over sixty years, and has been continually refitted and upgraded, still serving as the backbone of the fleet into the 2370s. The *Excelsior* features extensive shuttlebay and cargo facilities in the stern and keel.

The *U.S.S. Enterprise* NCC-1701-B was the first *Excelsior*-class ship to be built to an updated design, but most of the vessels in service still retain the standard configuration.



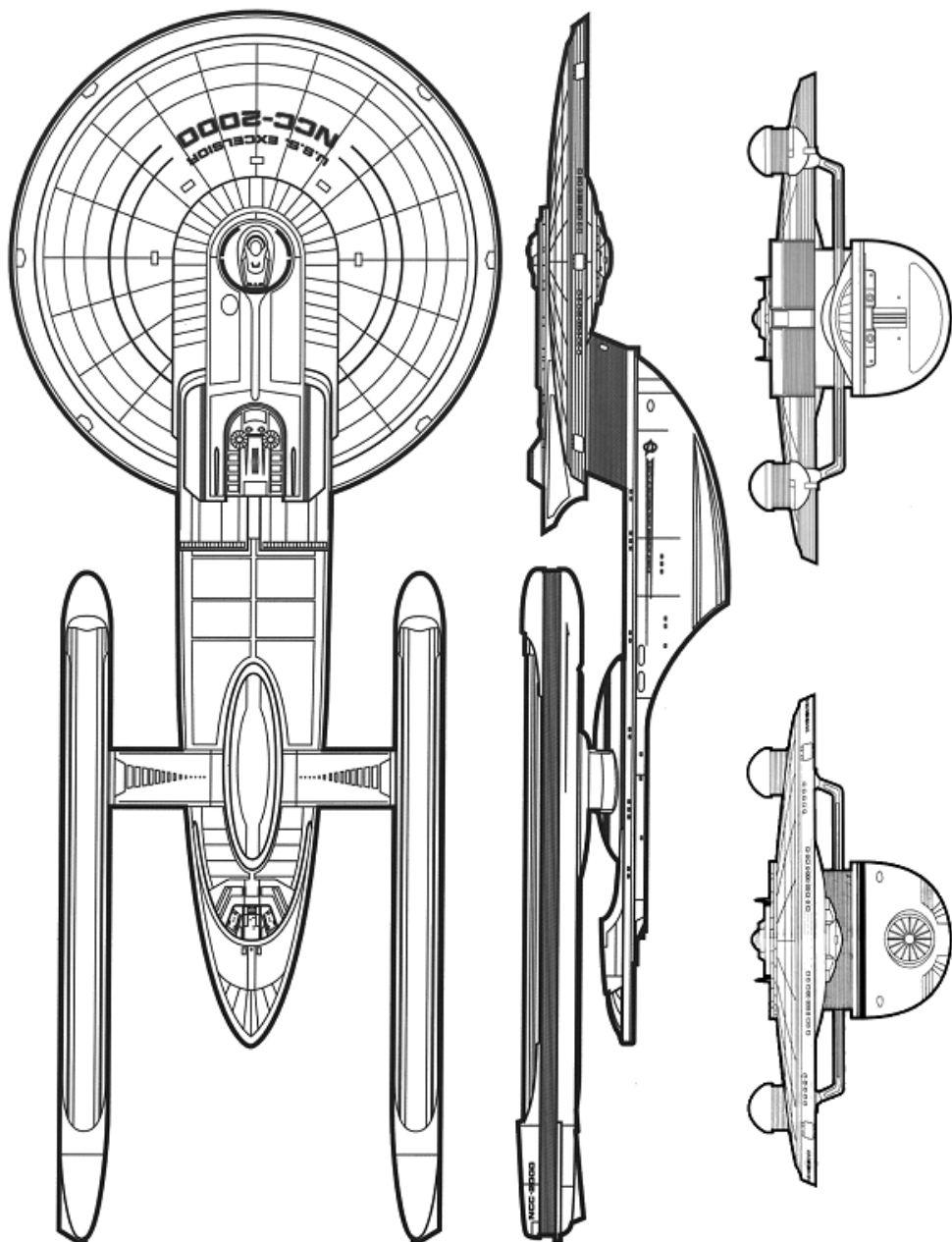

EXCELSIOR CLASS (Refit)

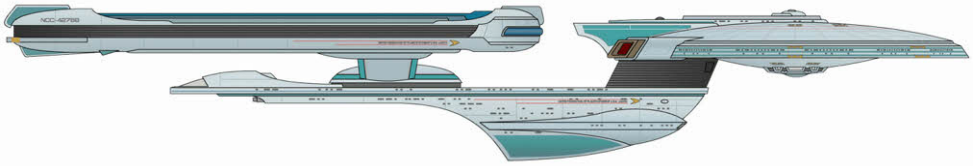

Class: Excelsior (Refit)

Type: Explorer

Commissioned: 2293

Production Base: Utopia

Length: 470.68 metres

Beam: 186 metres

Height: 78.86 metres

Mass: 2,350,000 metric tons

Crew: 750

Cruising Speed: Warp 8

Maximum Speed: Warp 9.3

Armament: 16 Type VIII phaser banks, 4 Mk 70 photon torpedo launchers

NCC Known Ships (USS)

1701-B Enterprise

42768 Lakota

CLASS INFORMATION:

Despite the failure of the Transwarp project of the 2280s, the otherwise sound *Excelsior*-class design was put into full production. The Advanced Starship Design Bureau continued to develop the class, and the first refit *Excelsior*, the *U.S.S. Enterprise* NCC-1701-B, was launched in 2293. The refit design featured updated warp and impulse engines, and two large sensor pods either side of the navigational deflector in the secondary hull. However only a relatively small number were produced compared to the more cost-effective standard design.

The *Enterprise-B*, commanded by Captain John Harriman, was a key vessel in the exploration of space beyond the Gourami Sector. The ship and her crew were responsible for mapping over 142 star systems, including first contact with seventeen civilisations. Another refit, the *U.S.S. Lakota* NCC-42768, participated in Admiral Thomas Leyton's failed military coup of Earth's government in 2372.



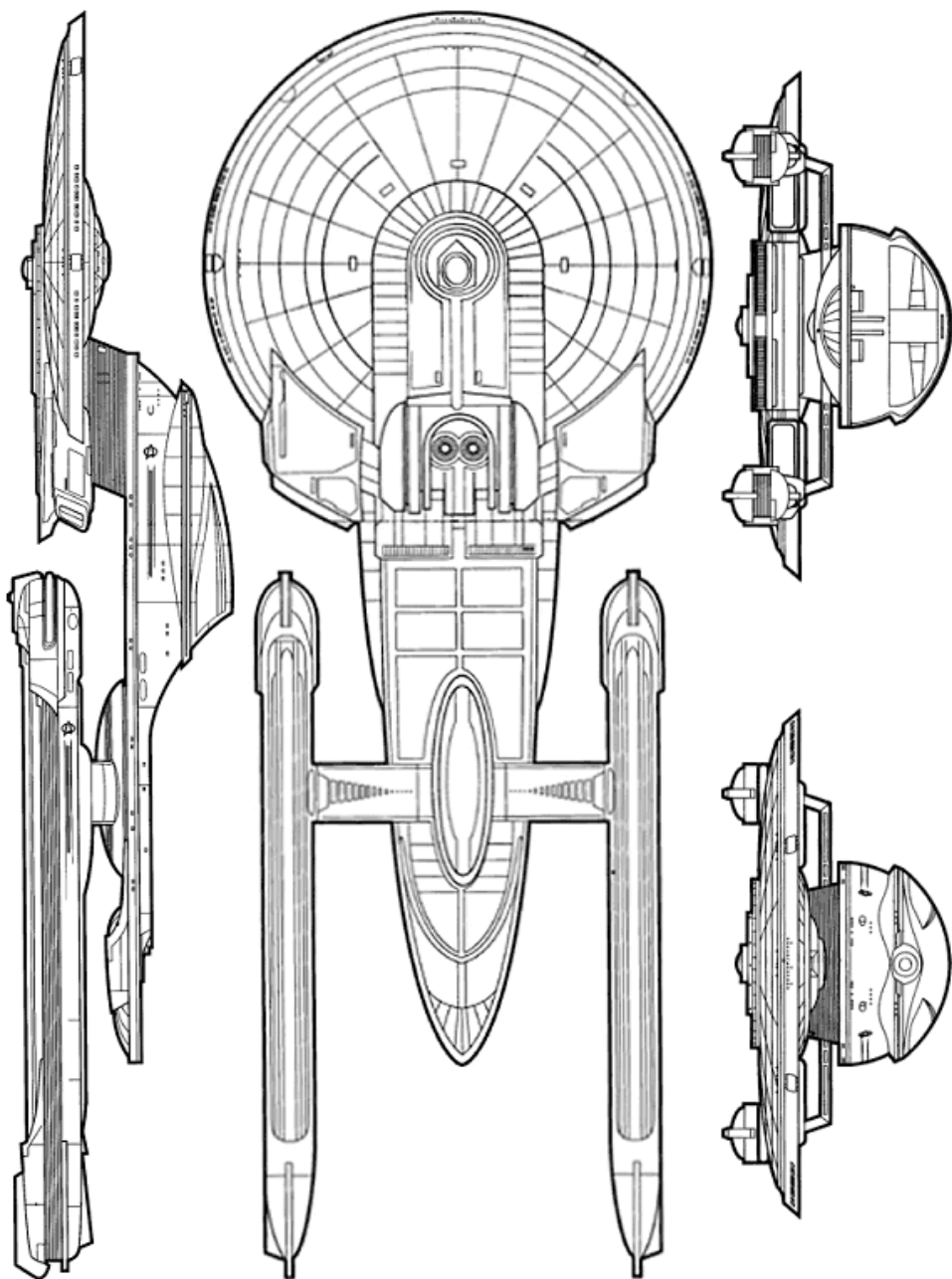

FREEDOM CLASS



Class: Freedom

Type: Destroyer

Commissioned: 2349

Production Base: Antares & Utopia Planitia Fleet Yards

Length: 430 metres

Beam: 265 metres

Height: 115 metres

Mass: 1,075,000 metric tons

Crew: 300

Cruising Speed: Warp 5

Maximum Speed: Warp 9

Armament: 6 Type IX phaser arrays, 2 Mk 75 photon torpedo launchers

NCC **Known Ships (USS)**

68711 Concord

68723 Firebrand †

Freedom

† *Lost or destroyed*

CLASS INFORMATION:

Hailing from the *Saladin/Hermes*-class design lineage, the *Freedom*-class was conceived as a relatively cheap, quick to build, 'new technology' destroyer design. It is mainly used for medium range research and scouting missions, and often encompasses greatly mixed crews.

The *Freedom*-class features a single *Galaxy*-class warp nacelle, whose warp coils are aligned in pairs, negating the need for a second nacelle to maintain a stable warp field. Like the *Oberth*-class, the *Freedom* design is often used in the civilian sector.

Notable ships of the class include the *U.S.S. Firebrand* NCC-68723, which was destroyed by the Borg at Wolf 359 in 2366-67, and the *U.S.S. Concord* NCC-68711.

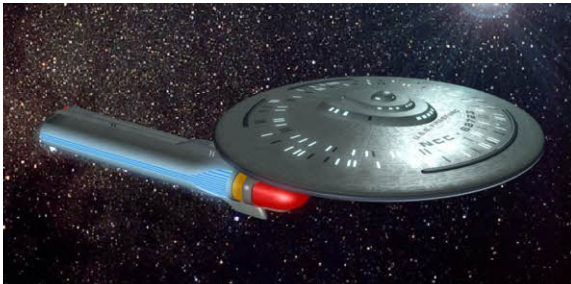

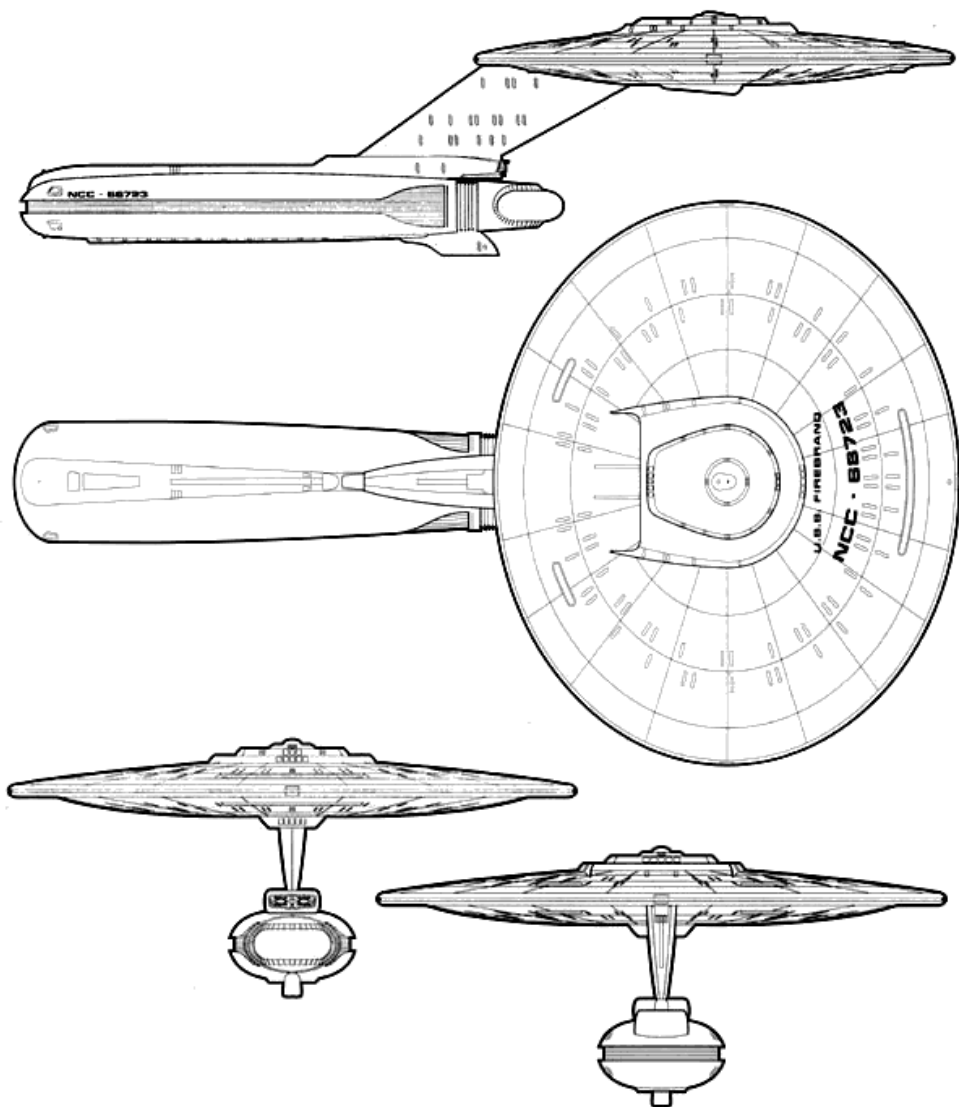

GALAXY CLASS

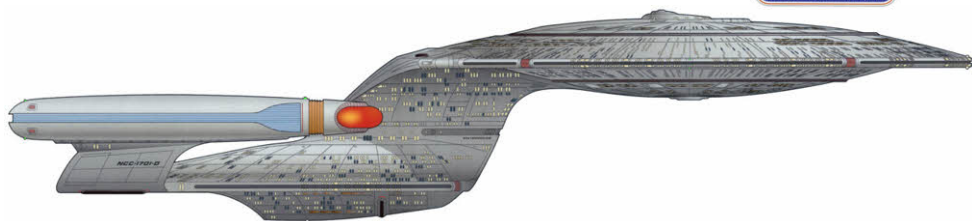

Class: Galaxy

Type: Explorer

Commissioned: 2357

Production Base: Utopia
Planitia Fleet Yards, Mars

Length: 641 metres

Beam: 467.1 metres

Height: 137.5 metres

Mass: 4,500,000 metric tons

Crew: 1,012

Cruising Speed: Warp 6

Maximum Speed: Warp 9.6

Armament: 12 Type X phaser
arrays, 3 Mk 80 photon torpedo
launchers

NCC Known Ships (USS)

71099 Challenger

1701-D Enterprise †

26517-A Excalibur *‡

70637 Galaxy

71820 Magellan

71832 Odyssey †

31347 Trident ‡

71867 Trinculo

71854 Venture *

71807 Yamato †

* Refit † Lost or destroyed

‡ Non-canon

CLASS INFORMATION:

The largest vessel in the fleet, the *Galaxy*-class took a record fourteen years to design and develop. A replacement for the aging *Ambassador*-class, the *Galaxy* represented a cutting-edge combination of existing and new technologies into an ambitious design. With a standard mission length of seven years, and twenty years between overhauls, these vessels could explore farther into space than ever before.

Galaxy-class starships were the first designed to support crew and their families, making them a coveted assignment. They also pioneered routine hull separation - the 'saucer section' being able to operate independently of the 'stardrive section'.

An initial set of six *Galaxy*-class vessels were built, including the much-decorated U.S.S. *Enterprise* NCC-1701-D. After the Borg incursion of 2366-67 - an attack which was foiled by the *Enterprise-D* - a further set of six spaceframes were assembled to an improved specification.



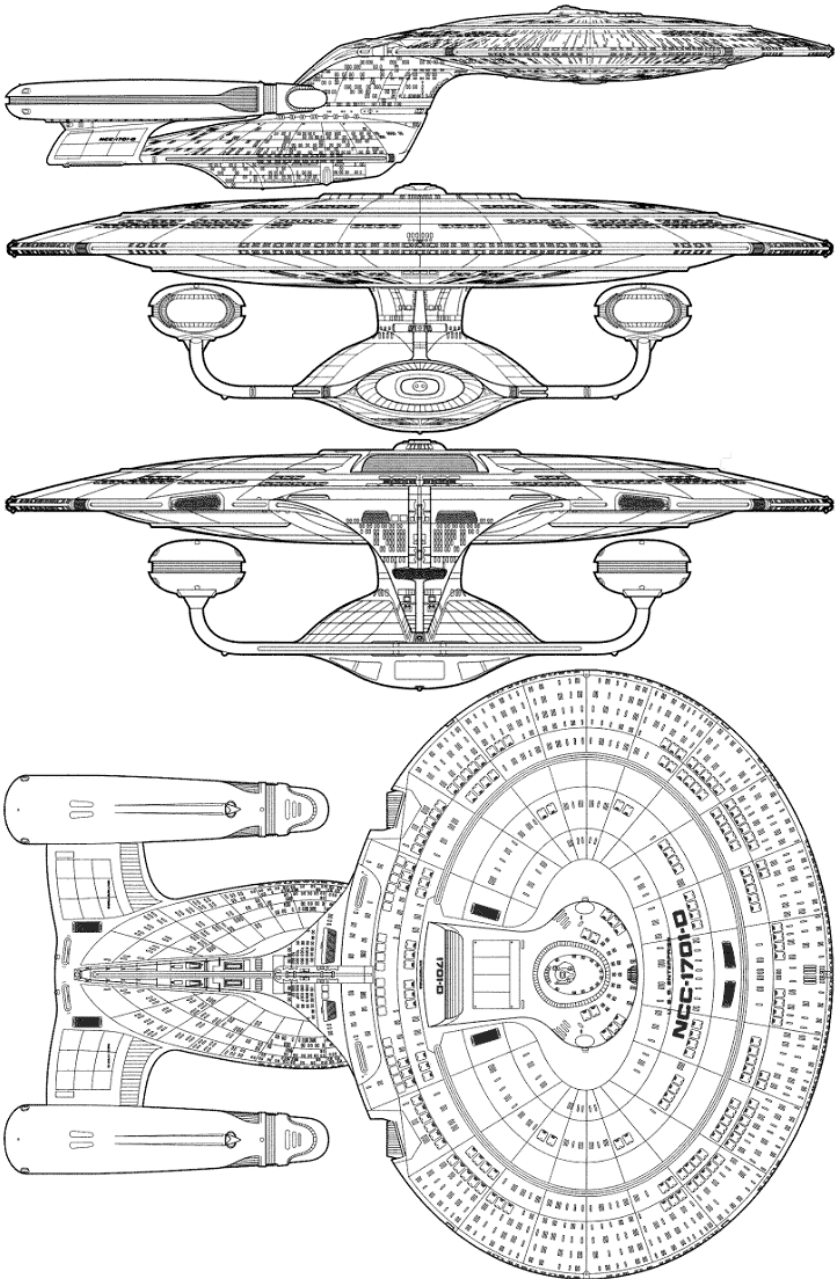

HOLOSHIP



Class: Unknown
Type: Holoship
Commissioned: 2375
Production Base: Unknown
Length: 247 metres
Beam: 100 metres
Height: 52.2 metres
Mass: 550,000 metric tons

Crew: 75
Cruising Speed: Warp 8
Maximum Speed: Warp 9
Armament: None

NX **Known Ships (USS)**
75115 (Name unknown)

CLASS INFORMATION:

The *Holoship* was a prototype Federation starship constructed by Section 31 and launched in 2375. The ship had a rectangular design, with an aft mounted bridge module, and warp nacelles set into the main body.

The vessel was built to serve as a mobile holodeck which could simulate surroundings familiar to its passengers. It was also equipped with fourteen long-range transporters and a cloaking device.

The *Holoship* was employed by Admiral Matthew Dougherty and Ahdar Ru'afo, the leader of the Son'a, to secretly transport the entire six hundred Ba'ku inhabitants off their planet without their knowledge, in order to utilise the metaphasic radiation present in the planet's rings. The ship was to be destroyed by Starfleet Command after the Ba'ku incident became public, but was captured by a group of Starfleet officers covertly working against Section 31.



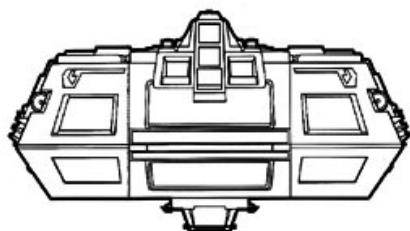
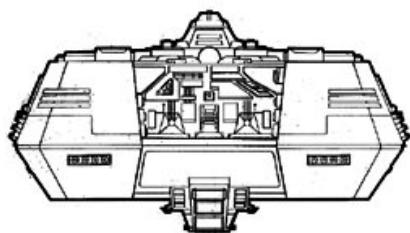
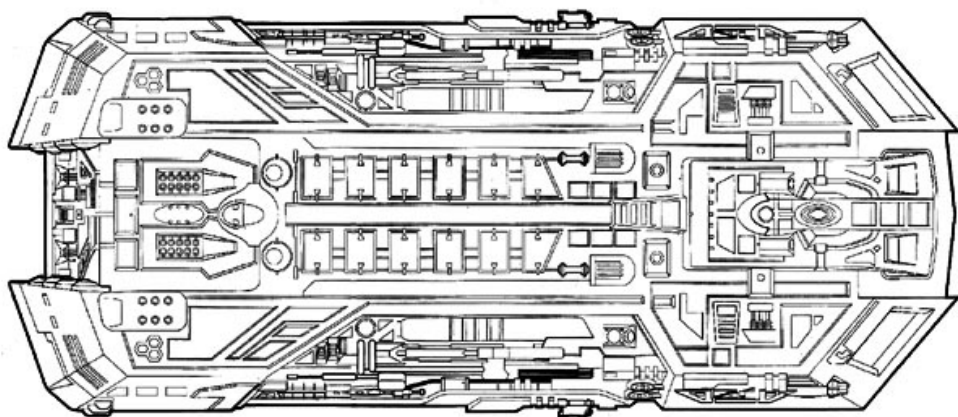
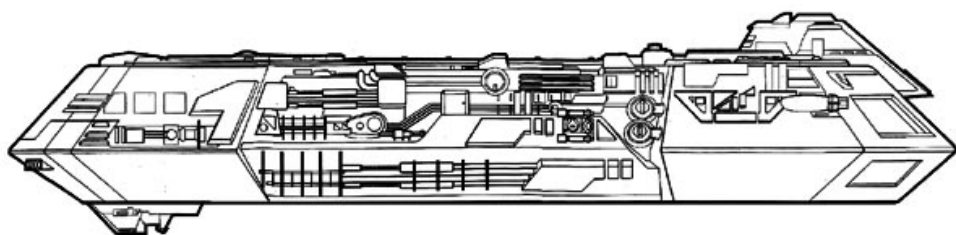

ICELAND CLASS



Class: Iceland/NU
Type: Escort/Surveyor
Commissioned: 2119
Production Base: Warp Five Complex, Earth
Length: 120 metres
Beam: 130 metres
Height: 20 metres

Mass: 25,000 metric tons
Crew: 30
Cruising Speed: Warp 1.2 *
Maximum Speed: Warp 2 *
Armament: 2 phase cannons

* *Original Cochrane Unit (OCU)*

NU Known Ships

NU-01 Iceland ϕ
 ϕ *Non-canon*

CLASS INFORMATION:

The *Iceland*-class was developed for planetary defence and survey roles in the Earth Starfleet of the early to mid 22nd century. The four deck 'warp delta' design was an evolution of the earlier *NA*-class S.S. *Emmette* solar explorer and the Lockheed Martin X-33 *Venture Star* orbiter spacecraft of the previous century,

A predecessor of the *NX*-class, the *Iceland* featured nuclear fusion power and was capable of warp two. The ship was initially armed with plasma cannons, though these were upgraded to phase cannons in the 2150s.

Two ships of this class came to the assistance of the *Enterprise NX-01* in 2153 when, on its return to Earth, it came under assault from a Klingon warship. Together with the starship *Intrepid*, the four Starfleet vessels managed to overwhelm the Klingons and drive them off.



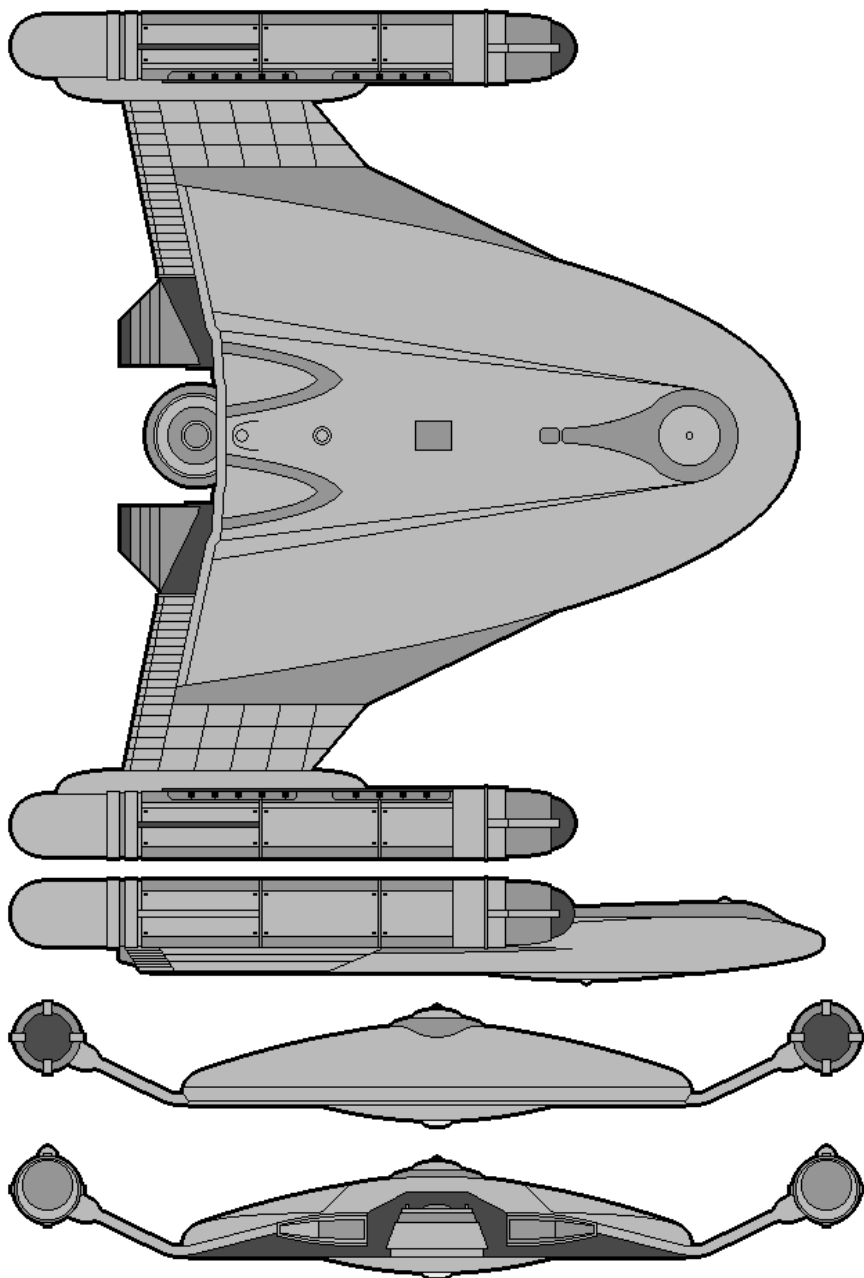

INTREPID CLASS

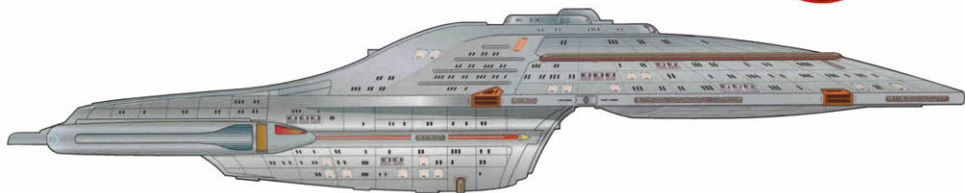

Class: Intrepid

Type: Light Explorer

Commissioned: 2370

Production Base: Earth Station
McKinley & Utopia Planitia

Length: 344.5 metres

Beam: 132.1 metres

Height: 64.4 metres

Mass: 700,000 metric tons

Crew: 150

Cruising Speed: Warp 9.8

Maximum Speed: Warp 9.975

Armament: 11 Type X phaser
arrays, 4 Mk 95 photon torpedo
launchers

NCC **Known Ships (USS)**

74705 Bellerophon

74121 Elkins *

74600 Intrepid

74656 Voyager

65674 Yeager *

* Variant

CLASS INFORMATION:

Commissioned in 2370, the *Intrepid*-class marks a change in Starfleet's design philosophy from larger, more complicated ships to smaller, more efficient vessels. The compact *Intrepid* features variable geometry warp nacelles which maximise efficiency, allowing very high speeds from a comparatively small power source, while minimising damage to the fabric of space. The class is also equipped with spare components to replace its warp core. The ship's advanced computer system was the first to use bio-neural gel packs for enhanced processing speed. Finally the *Intrepid*-class pioneered landing systems allowing it to make routine planetfall.

Four *Intrepid*-class starships were initially commissioned. The second, the *U.S.S. Voyager* NCC-74656, made more first contacts than any other Federation starship while marooned in the Delta Quadrant from 2371 to 2377.

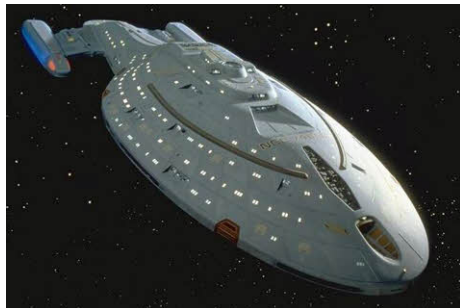

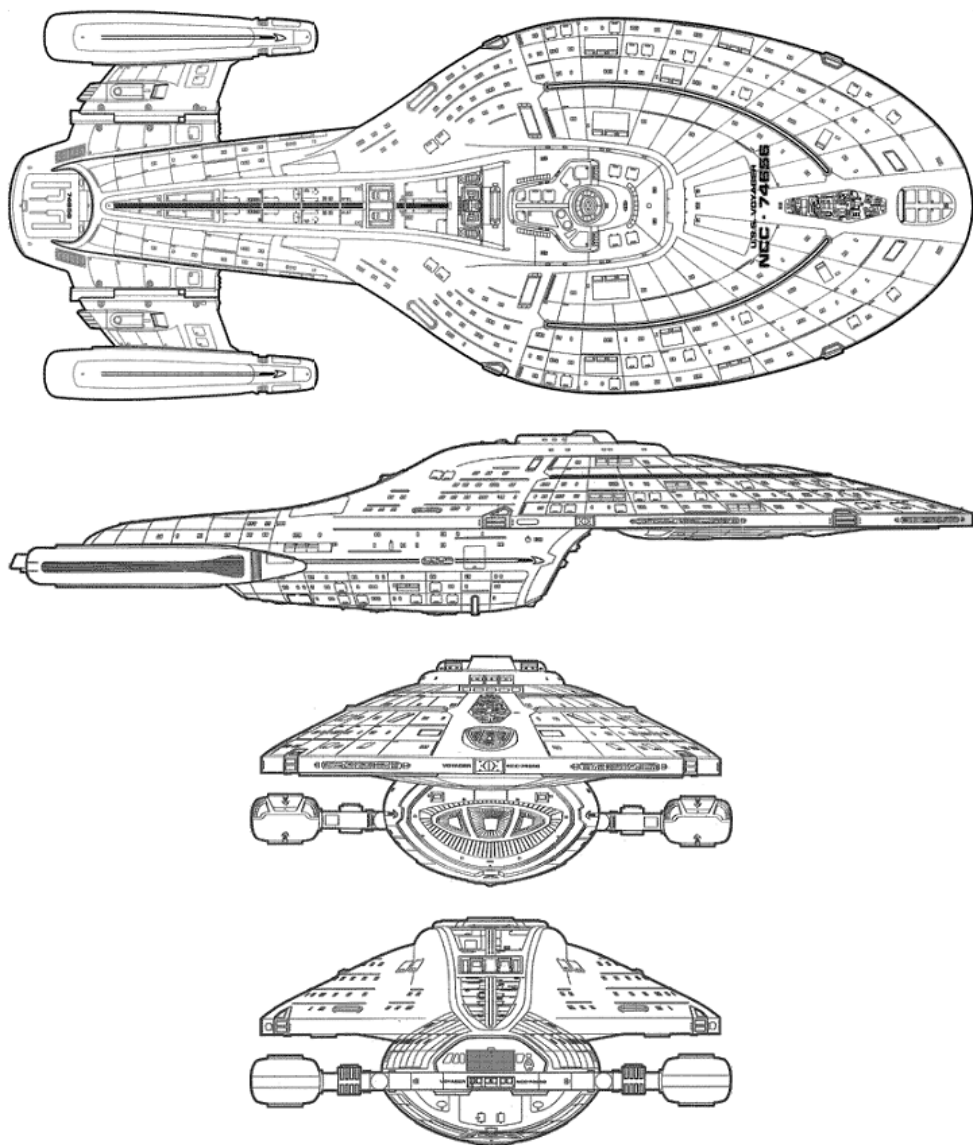

MIRANDA CLASS

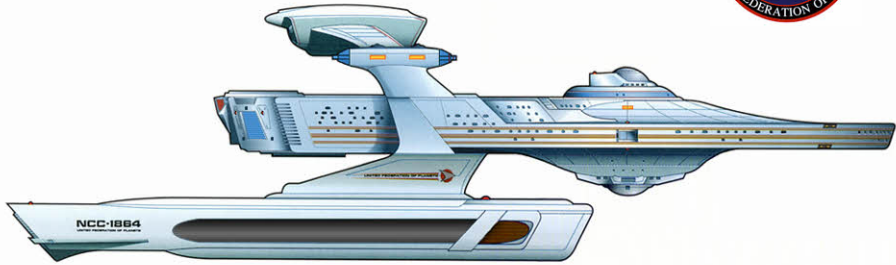

Class: Miranda
Type: Medium Cruiser
Commissioned: 2283
Production Base: 40 Eridani A Yards & Starbase 134, Rigel VI
Length: 237.6 metres
Beam: 141.7 metres
Height: 58 metres

Mass: 150,000 metric tons
Crew: 360
Cruising Speed: Warp 6
Maximum Speed: Warp 9.2
Armament: 6 Type VII phaser banks, 2 pulse phaser cannons, 4 Mk 22 photon torpedo launchers (optional)

NCC	Known Ships (USS)
21166	Brattain
1856	Emden
1837	Lantree *†
31060	Majestic †
	Miranda
31910	Nautilus
1864	Reliant †
1867	Saratoga
31911	Saratoga *†
31905	Shirkahr †
	Sitak †
21382	Tian An Men †
1948	Trial
13741	(Name unknown)
	* Variant
	† Lost or destroyed

CLASS INFORMATION:

One of Starfleet's most successful and long-lived designs, the *Miranda*-class entered service in 2283 and was still a mainstay of the fleet over ninety years later.

Developed as a complement to the refit *Constitution*-class in the late 23rd century, the *Miranda*'s ease of construction and adaptability meant Starfleet produced the vessel in large numbers.

The *Miranda*-class can be customised for a variety of tasks, including combat, scientific research, support services and cargo transport. A removable weapons bar holds pairs of forward and aft torpedo tubes, plus twin pulse phaser cannons which draw power direct from the main plasma conduits to the warp nacelles. Outboard weapon and sensor mounts can also be added instead of the rollbar.



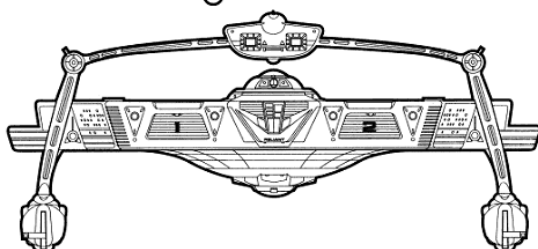
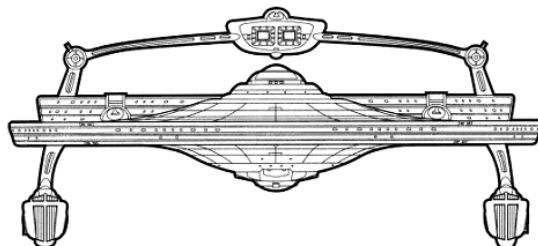
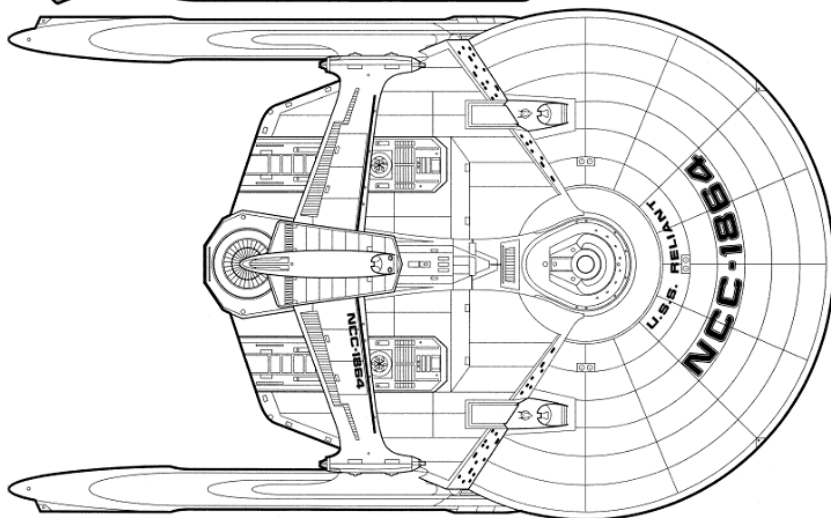
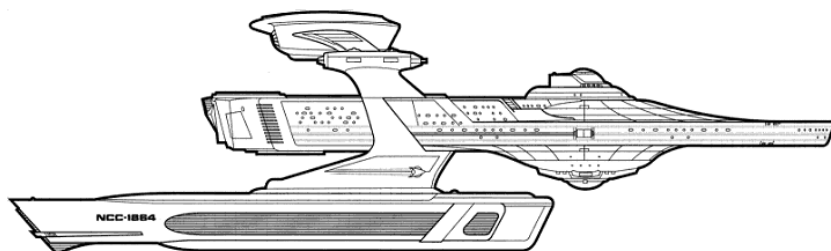

NEBULA CLASS

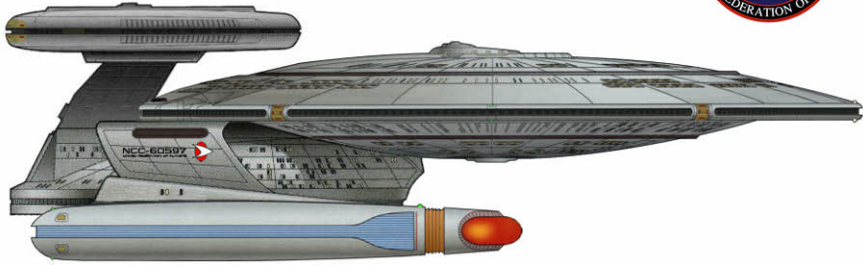

Class: Nebula

Type: Explorer

Commissioned: 2357

Production Base: Utopia Planitia & San Francisco Fleet Yards

Length: 465 metres

Beam: 467.1 metres

Height: 140.5 metres

Mass: 3,309,000 metric tons

Crew: 750

Cruising Speed: Warp 6

Maximum Speed: Warp 9.6

Armament: 8 Type X phaser arrays, 3 Mk 80 photon torpedo launchers

NCC **Known Ships (USS)**

62048 Bellerophon †

70915 Bonchune *

71805 Endeavour

60597 Farragut †
Garuda

62006 Hera †

60205 Honshu †

70352 Leeds

61832 Lexington

61827 Merrimac

61826 Monitor

60147 Nebula

65420 Phoenix *

71201 Prometheus

61952 Proxima †

72015 Sutherland

62100 T'Kumbra

66808 Ulysses

* Variant † Lost or destroyed

CLASS INFORMATION:

The *Nebula*-class starship shares many of the same components and technology as the larger *Galaxy*-class. Developed in parallel and also commissioned in 2357, the *Nebula*'s cost-effective and more compact design has made it one of the most common ships in the fleet.

The *Nebula*-class features a large, interchangeable upper equipment module. The ship can be configured for a variety of mission profiles with a tactical, sensor, cargo or probe pod. Combined with flexible primary systems this makes the *Nebula* one of Starfleet's most versatile vessels.

The *U.S.S. Sutherland* NCC-72015, under the command of Lt. Cmdr. Data, foiled a Romulan supply line to the Duras family during the Klingon Civil War.

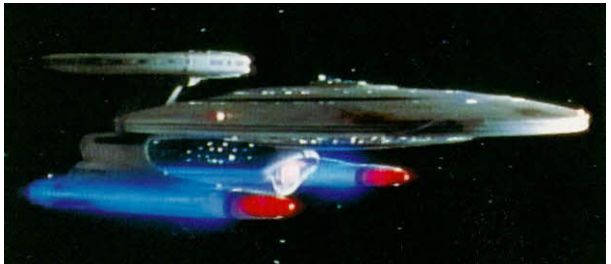

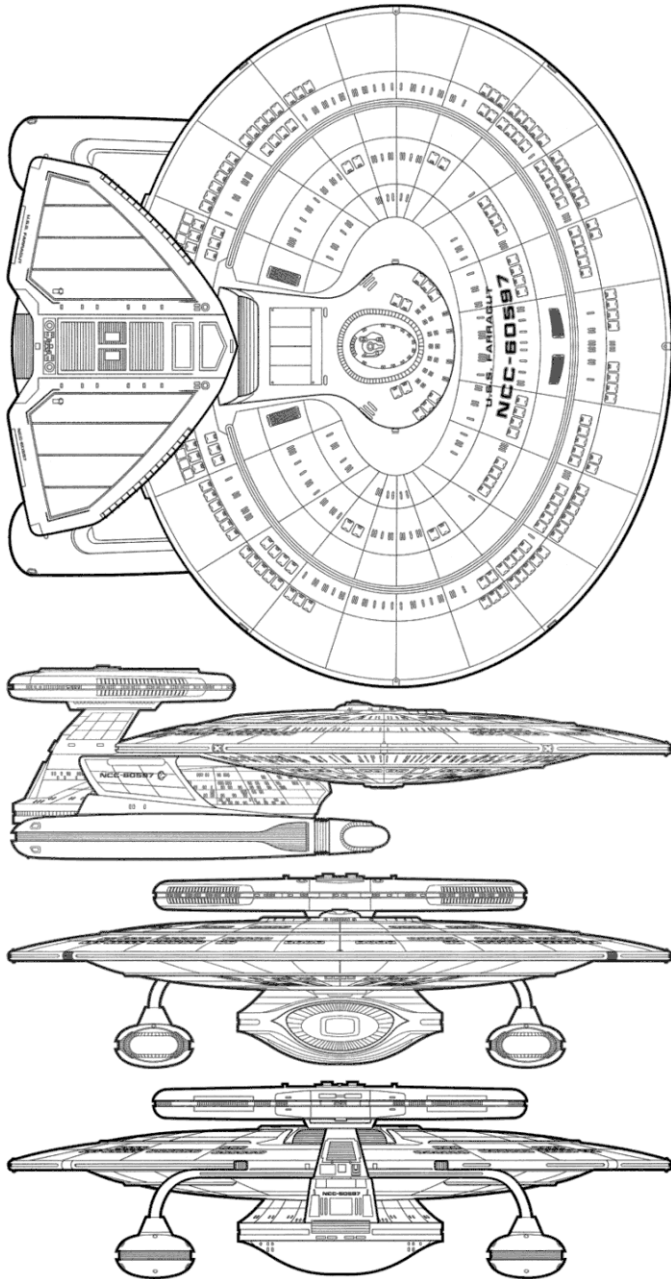

NEW ORLEANS CLASS

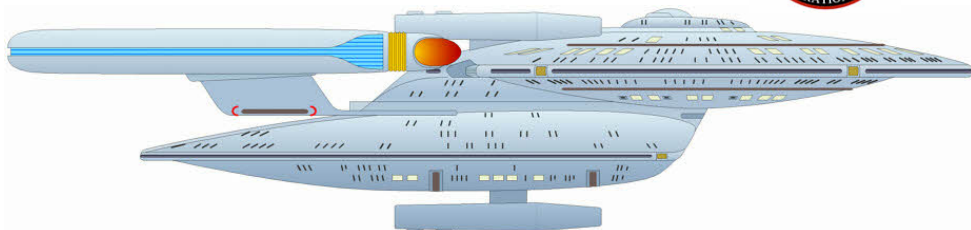

Class: New Orleans

Type: Frigate

Commissioned: 2345

Production Base: San Francisco Fleet Yards, Earth

Length: 360.74 metres

Beam: 258.66 metres

Height: 83.33 metres

Mass: 1,650,000 metric tons

Crew: 460

Cruising Speed: Warp 5

Maximum Speed: Warp 9.3

Armament: 6 Type IX phaser arrays, 3 Mk 80 photon torpedo launchers

NCC **Known Ships (USS)**

65491 Kyushu †

 New Orleans

63102 Renegade

57295 Rutledge

65530 Thomas Paine

† *Lost or destroyed*

CLASS INFORMATION:

The *New Orleans*-class was one of Starfleet's most numerous frigate designs during the mid-24th century. The class features three outboard photon torpedo pods, two dorsal and one ventral, making it well suited for combat. The *New Orleans* also has an elliptical saucer section, similar in style to those which would later be used on the *Galaxy*-class, but considerably smaller in size.

Famous *New Orleans*-class ships include the *U.S.S. Rutledge* NCC-57295, which fought in the Cardassian War under the command of Captain Benjamin Maxwell, and the *U.S.S. Kyushu* NCC-65491, which was destroyed by the Borg at Wolf 359 in 2366-67.

The *New Orleans*-class has now been superseded by the similar-sized *Steamrunner*-class as Starfleet's lead frigate design.



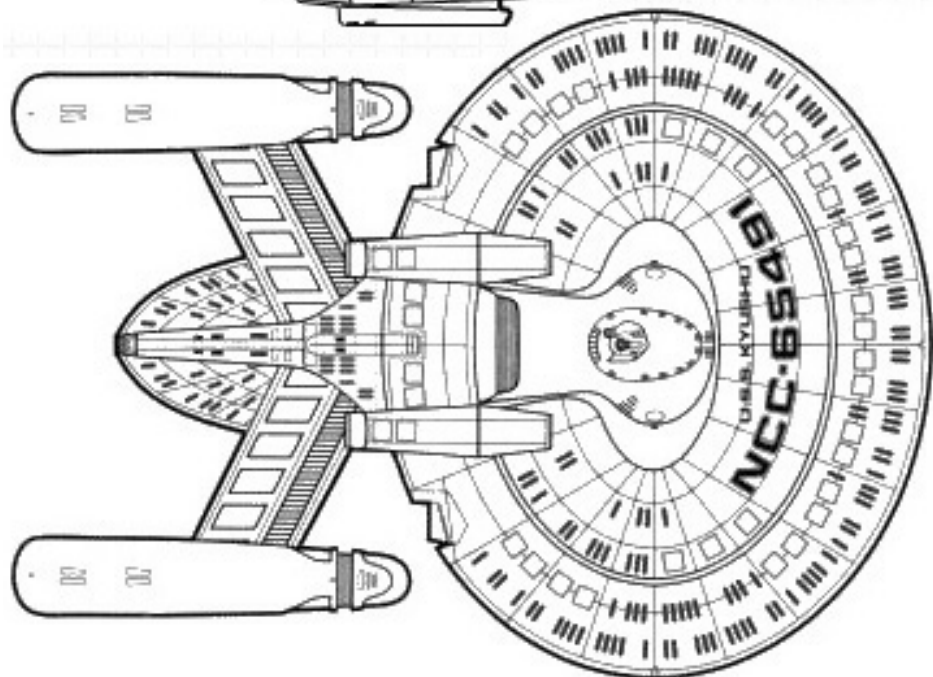
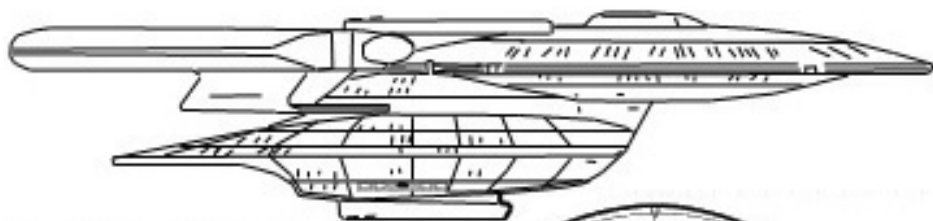

NIAGARA CLASS

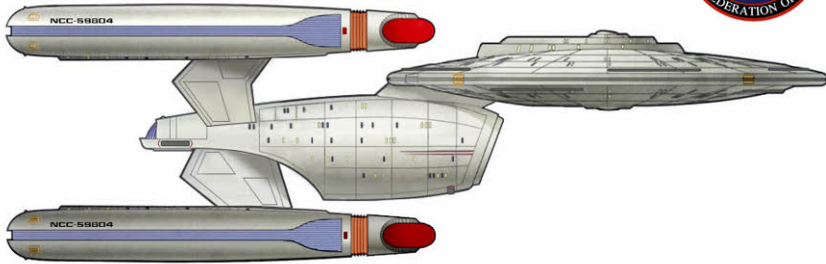

Class: Niagara

Type: Fast Cruiser

Commissioned: 2343

Production Base: Utopia Planitia & San Francisco Fleet Yards

Length: 450.5 metres

Beam: 264.79 metres

Height: 156.44 metres

Mass: 2,350,000 metric tons

Crew: 585

Cruising Speed: Warp 6

Maximum Speed: Warp 9.6

Armament: 12 Type IX phaser arrays, 2 Mk 75 photon torpedo launchers

NCC **Known Ships (USS)**

Niagara

59804 Princeton †

28473 Wellington

† *Lost or destroyed*

CLASS INFORMATION:

The *Niagara*-class features an unusual three-nacelle configuration, sacrificing warp field efficiency for higher cruising speed, greater manoeuvrability, and the ability to travel on one engine while resting the others - extending component life. However the long pylons make vulnerable targets, lessening its effectiveness in combat.

The *Niagara* uses much of the same technology as the *Ambassador*-class, and is fitted with Grade 4 diplomatic facilities, enabling it to handle multi-planetary conferences involving several high-level diplomats and their staffs.

The remaining *Niagaras* in service are now deployed on astronomical research missions, as the class has long since been overshadowed by more modern and advanced starships. Notable vessels of the class include the *U.S.S. Wellington* NCC-28473, and the *U.S.S. Princeton* NCC-59804, which fell at Wolf 359.



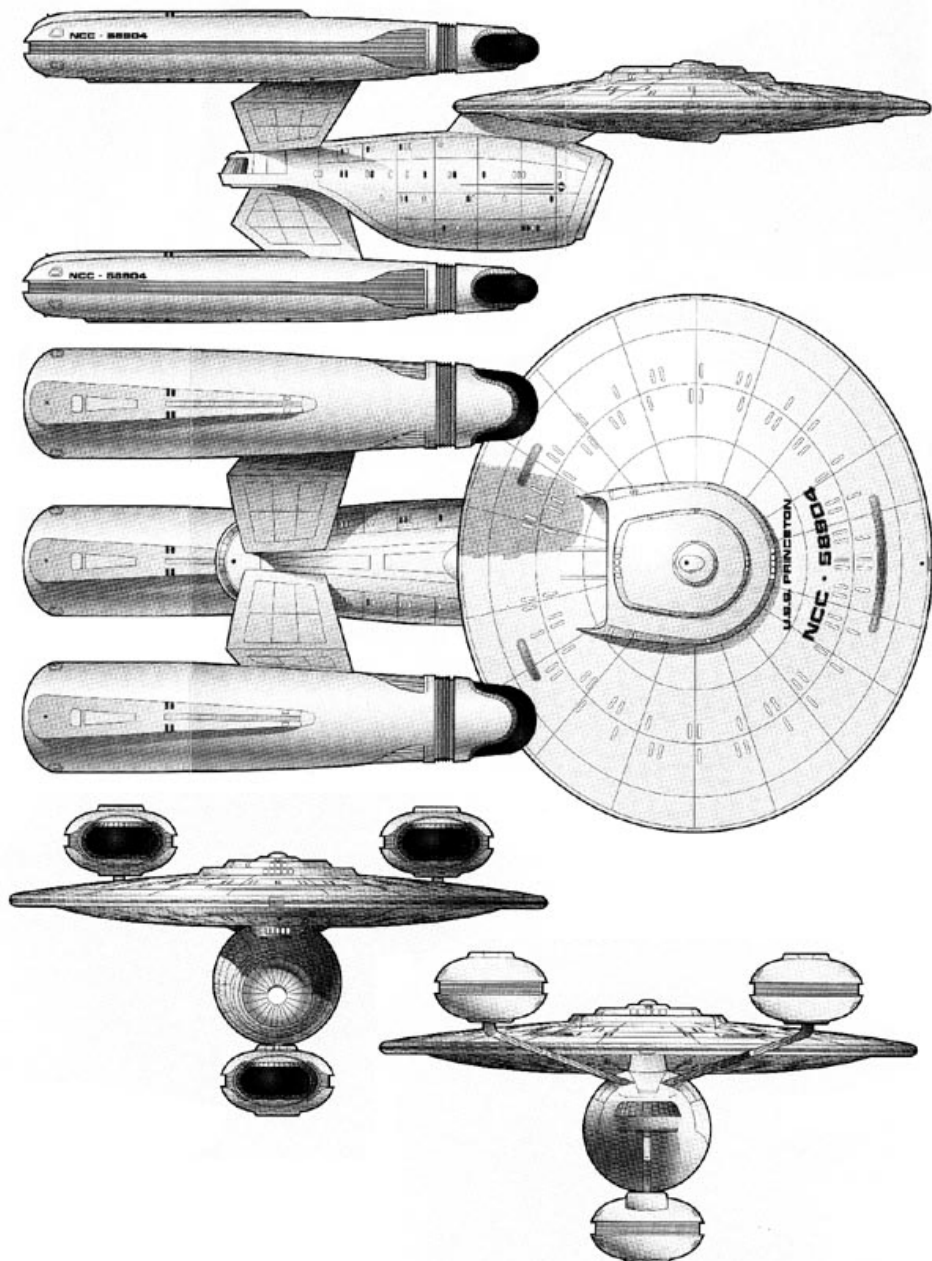

NORWAY CLASS



Class: Norway
Type: Medium Cruiser
Commissioned: 2371
Production Base: Spacedock One, Earth
Length: 355 metres
Beam: 229 metres
Height: 52 metres

Mass: 622,000 metric tons
Crew: 190
Cruising Speed: Warp 6
Maximum Speed: Warp 9.7
Armament: 6 Type X phaser arrays, 1 phaser cannon, 2 Mk 80 photon torpedo launchers

NCC	Known Ships (USS)
64923	Budapest
64834	Canopus
	Norway
64924	Tannu Tuva

CLASS INFORMATION:

The *Norway*-class was designed in the same Starfleet initiative that produced the *Saber* and *Steamrunner*-classes, and was intended primarily as an advanced escort vessel. The *Norway* features a revolutionary low-profile design which presents a smaller target in combat. Completed in time to assist the fleet against the Borg incursion into Sector 001 in 2373, the *Norway*-class proved itself as a versatile combat vessel and saw action again in the Dominion War.

The *Norway* sacrifices some of the speed and manoeuvrability of the smaller *Saber*-class for heavier armour and more weaponry. The *Norway* also features a distinctive forward-mounted phaser cannon in the front part of the primary hull, unique amongst Starfleet vessels.

Notable ships of the *Norway*-class include the *U.S.S. Budapest* NCC-64923, which played a key role in the destruction of the Borg cube in the 2373 invasion.



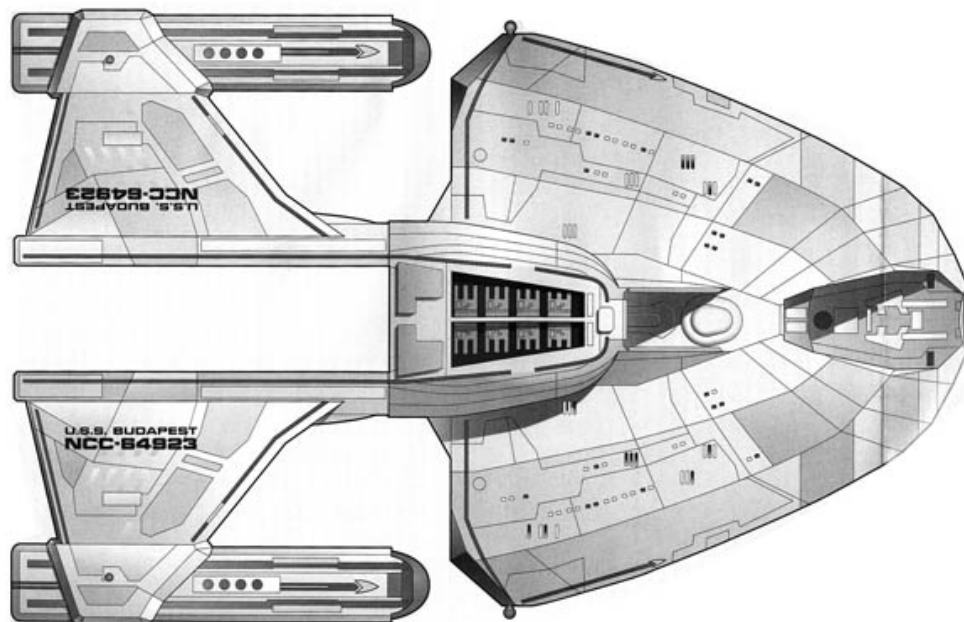
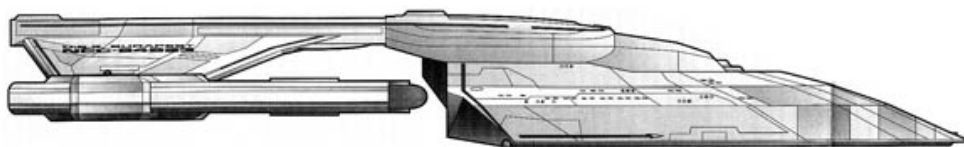

NOVA CLASS



Class: Nova
Type: Surveyor
Commissioned: 2368
Production Base: Utopia Planitia Fleet Yards, Mars
Length: 221.74 metres
Beam: 109.5 metres
Height: 41.91 metres

Mass: 110,000 metric tons
Crew: 80
Cruising Speed: Warp 6
Maximum Speed: Warp 8
Armament: 11 Type X phaser arrays, 3 Mk 95 photon torpedo launchers

NCC **Known Ships (USS)**
72381 Equinox †
73515 Nova
72701 Rhode Island *
* Variant † Lost or destroyed

CLASS INFORMATION:

Starfleet's successor to the long-lived *Oberth*-class surveyor, the *Nova*-class was first commissioned in 2368 and is designed for short-range, limited duration research missions. Essentially a flying sensor platform, the *Nova*-class's advanced, integrated sensor suite allows research to a level unparalleled in Starfleet history.

The spaceframe itself was originally the *Defiant*-class 'pathfinder' prototype, before that project was redefined with the looming threat of the Borg. Like the *Intrepid*-class, the *Nova* has landing capability, and carries an advanced atmospheric operations shuttlecraft, the *Waverider*, in the underside of its primary hull.

The *U.S.S. Equinox* NCC-72381 vanished near the Badlands in 2370. It was later discovered in the Delta Quadrant by the *U.S.S. Voyager*, having survived in conditions far above its design parameters - proving the effectiveness of the design.



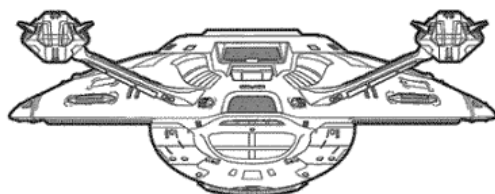
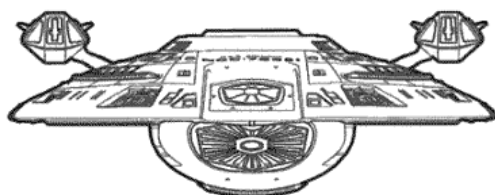
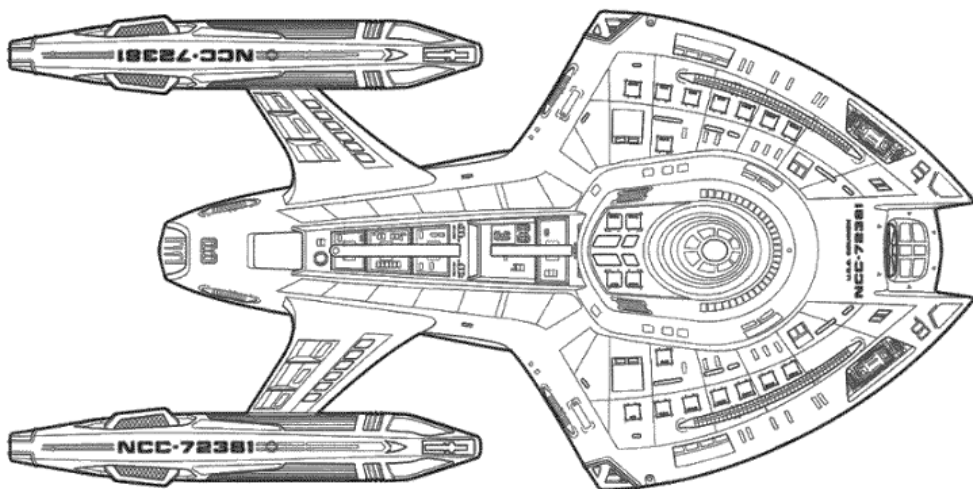
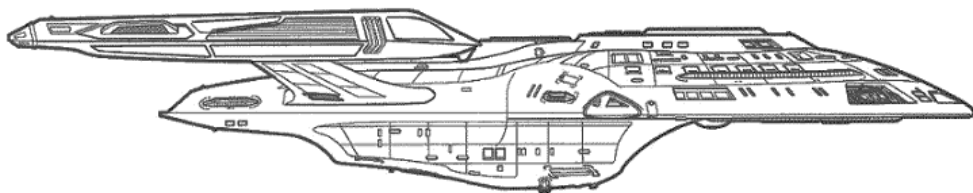

NV CLASS

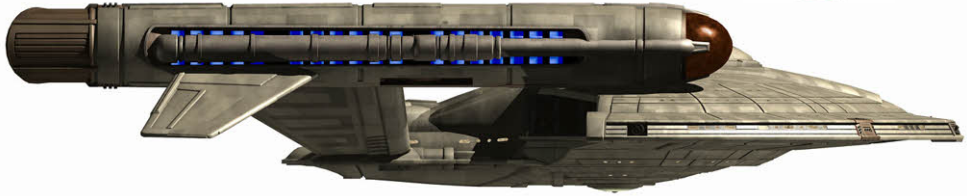

Class: NV/Neptune
Type: Cruiser
Commissioned: 2141
Production Base: Warp Five Complex, Earth
Length: 170 metres
Beam: 135 metres
Height: 30 metres

Mass: 40,000 metric tons
Crew: 40
Cruising Speed: Warp 1.2 *
Maximum Speed: Warp 2 *
Armament: 4 phase cannons, 2 spatial/photonic torpedo launchers
* *Original Cochrane Unit (OCU)*

NV Known Ships
Neptune
NV-01 ♀ Intrepid
♀ *Non-canon registry*

CLASS INFORMATION:

The NV or *Neptune*-class was a 22nd-century Earth Starfleet design developed as a solar explorer and survey vessel. Launched in 2141, the NV featured a tapered 'half saucer' attached to a compact engineering hull assembly. The ship's warp nacelles had distinctive fins sticking outward from their rear sections, which improved the efficiency of the ship's warp field.

The class continued in service through the mid-22nd century, before eventually being superseded by the warp five NX-class design.

The NV-class *Intrepid* was the lead ship of the Earth Defence Fleet in the early 2150s. In 2153, the *Intrepid*, under the command of Captain Carlos Ramirez, aided the returning *Enterprise* NX-01 on its way back to Earth when it was attacked by a Klingon Bird-of-Prey.

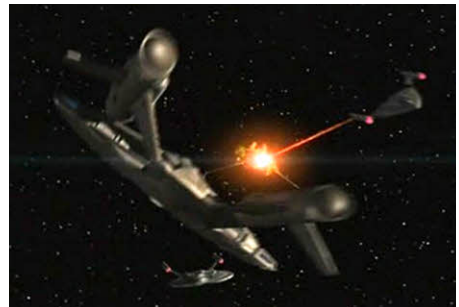

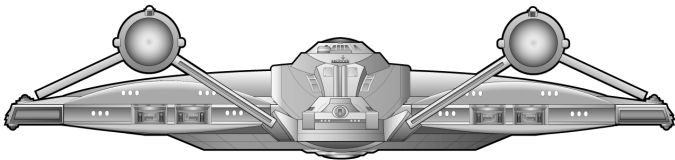
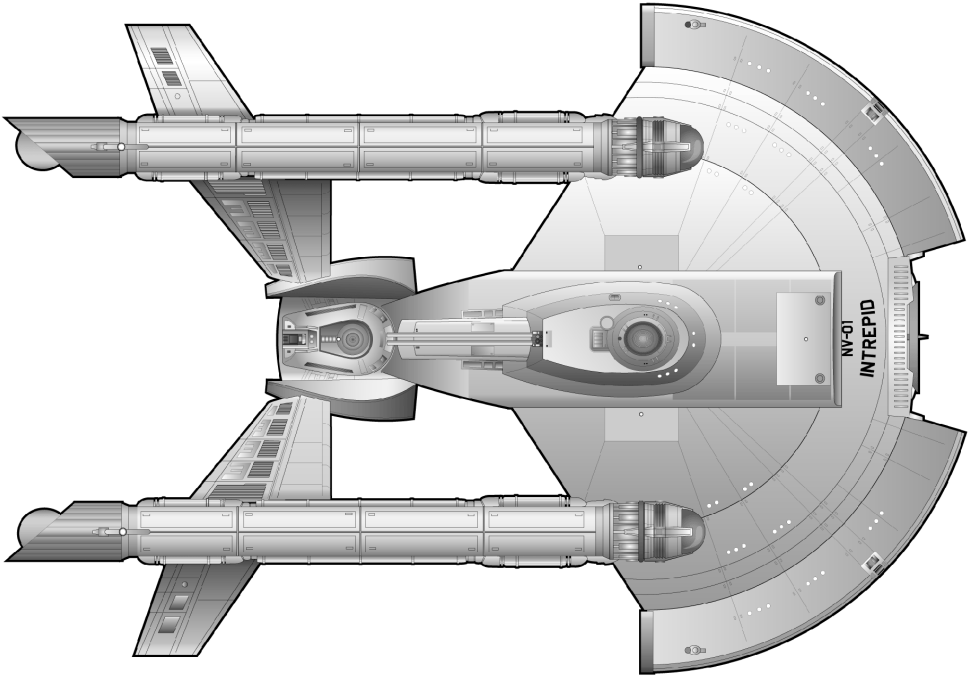
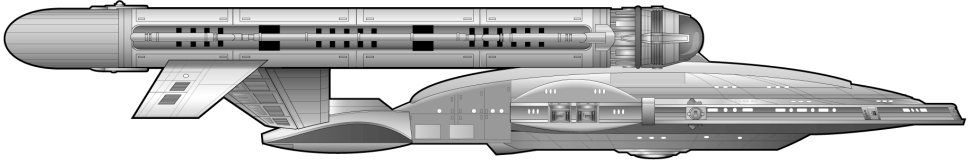

NX CLASS



Class: NX/Enterprise
Type: Explorer
Commissioned: 2151
Production Base: Warp Five Complex, Earth
Length: 225 metres
Beam: 135.8 metres
Height: 33.3 metres

Mass: 80,000 metric tons
Crew: 83
Cruising Speed: Warp 4.5 *
Maximum Speed: Warp 5.2 *
Armament: 4 Plasma cannons, 4 phase cannons, 6 spatial/photonic torpedo launchers
* *Original Cochrane Unit (OCU)*

NX	Known Ships
NX-01	Enterprise
NX-02	Columbia
NX-03	Challenger †
NX-04	Discovery †
NX-09	Avenger *†
* <i>Mirror universe vessel</i>	
† <i>Lost or destroyed</i>	
‡ <i>Non-canon name</i>	

CLASS INFORMATION:

The first Warp Five capable vessel built by Starfleet, the *NX-class* paved the way for a new era of human exploration. Representing the pinnacle of mid-22nd century starship design, the *NX* featured transporters, spatial torpedoes (later upgraded to photonic torpedoes), phase cannons, hull polarisation, a magnetic 'grappler', and the revolutionary Warp Five engine, designed by Dr Henry Archer. The engine allowed journeys that at one time took years to be completed in a matter of weeks.

An initial run of four *NX-class* vessels were built. The first, the *Enterprise NX-01*, was launched in 2151 under the command of Dr Archer's son, Captain Jonathan Archer. During its historic mission, the *Enterprise* made first contact with numerous species, including the Klingons, Suliban, Andorians, Xyrillians and Tandarans. The ship and its crew also averted the destruction of Earth by the Xindi in the Delphic Expanse in 2154, and played a pivotal role in building the alliance of species which would eventually become the United Federation of Planets in 2161.



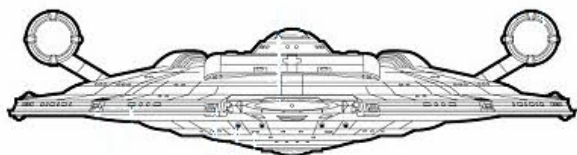
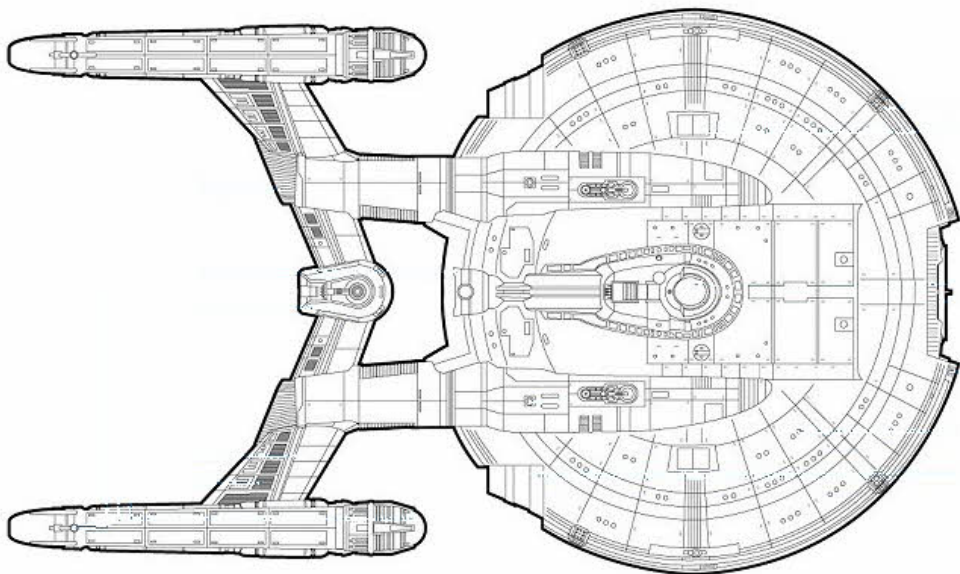
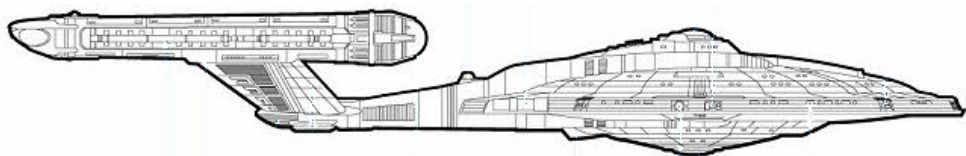

NX PROTOTYPE



Class: NX Prototype
Type: Warp 3 Prototype
Commissioned: 2143
Production Base: Warp Five Complex, Earth
Length: 20 metres
Beam: 14 metres
Height: 2.5 metres

Mass: 40 metric tons
Crew: 2
Cruising Speed: Warp 2 *
Maximum Speed: Warp 3 *
Armament: None

* *Original Cochrane Unit (OCU)*

Known Ships

NX-Alpha
NX-Beta
NX-Gamma
NX-Delta

CLASS INFORMATION:

The *NX Prototype* was used as a testbed for Earth Starfleet's NX Project - to develop a starship using the engine designed by the Warp Five programme. Prior to the project, Human ships were only capable of achieving Warp 2.

First launched in 2143, the two-seater prototypes comprised of a rocket-shaped main hull with various fins and control surfaces at the rear. Two warp nacelles were mounted to the sides via wings that could be folded to optimise hangar space.

NX-Alpha, the first of the prototypes, was piloted by A.G. Robinson. It broke apart after Robinson had reached Warp 2.2. Shortly after that, Jonathan Archer and Robinson achieved Warp 2.5 during an unauthorised flight on *NX-Beta*. After the ships had been grounded for extensive simulations, the Vulcans confirmed that the engine would work. Eight months later, Duvall broke the Warp 3 barrier on *NX-Delta*.



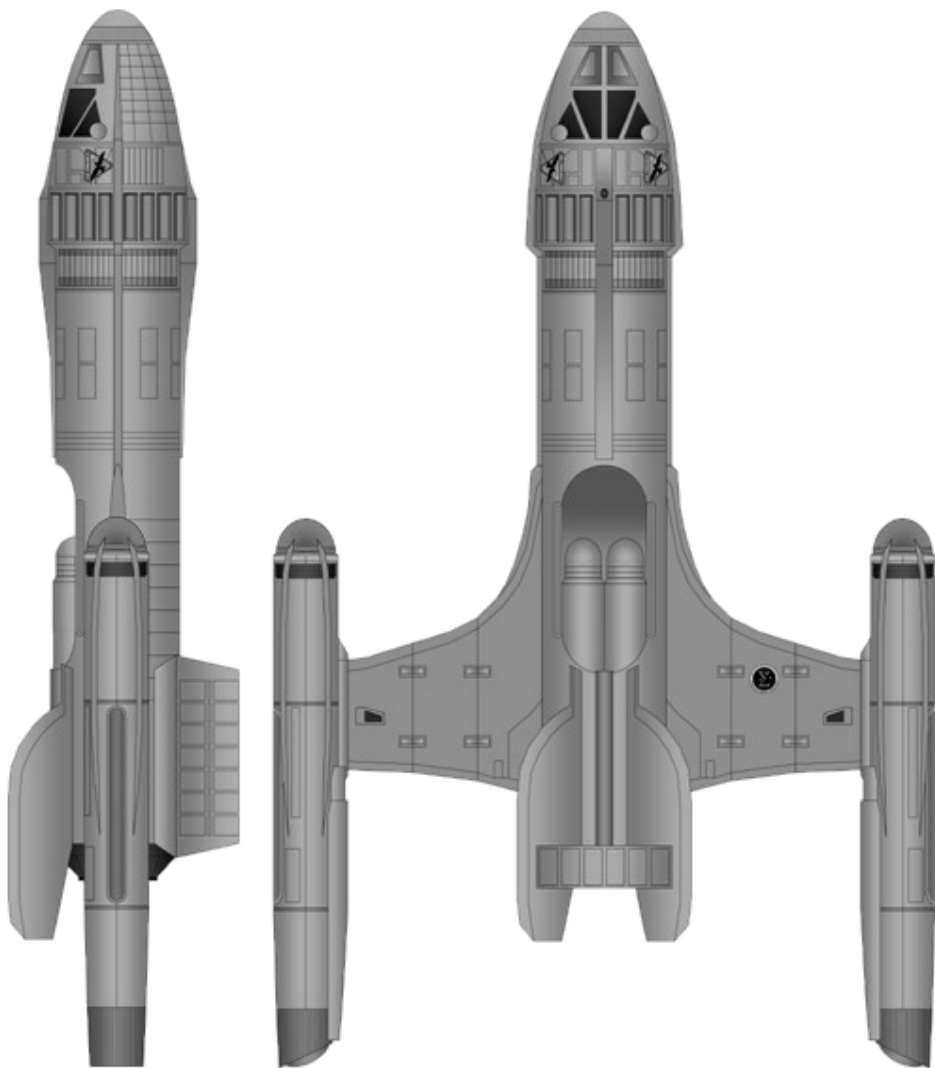

OBERTH CLASS

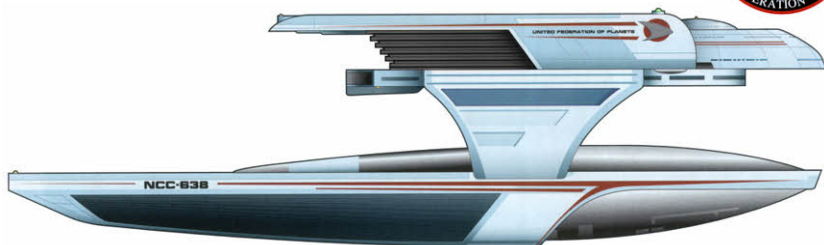

Class: Oberth

Type: Surveyor

Commissioned: 2280

Production Base: Copernicus
Yards & Baikonur Cosmodrome

Length: 159.83 metres

Beam: 82.97 metres

Height: 44.34 metres

Mass: 94,000 metric tons

Crew: 78

Cruising Speed: Warp 5

Maximum Speed: Warp 7

Armament: 3 Type VII phaser
banks, 1 probe/photon torpedo
launcher

NCC **Known Ships (USS)**

50331 Biko

31600 Bonestell †

59318 Cochrane

623 Copernicus

638 Grissom †

1692 Helin

602 Oberth

53847 Pegasus †

29487 Raman †

1963 Springfield

53911 Tsiolkovsky †

20000 Valiant

18834 Vico *†

19002 Yosemite

* *Civilian ship (NAR registry)*

† *Lost or destroyed*

CLASS INFORMATION:

Starfleet's primary dedicated science vessel for over eighty years, the *Oberth*-class was first introduced in the 2280s. Designed to free up larger *Constitution* and *Miranda*-class vessels from pure research missions, the lightly-armed *Oberth* is effectively a flying laboratory. The *Oberth* also features a unique hull arrangement - physical travel between the primary and secondary hulls can only be done via the warp nacelle pylons.

Oberth-class vessels are frequently used in the civilian sector as well as by Starfleet. The class was named for 20th century German rocket pioneer Hermann Oberth. The *Oberth*-class was gradually replaced by the *Nova*-class in the 2370s.



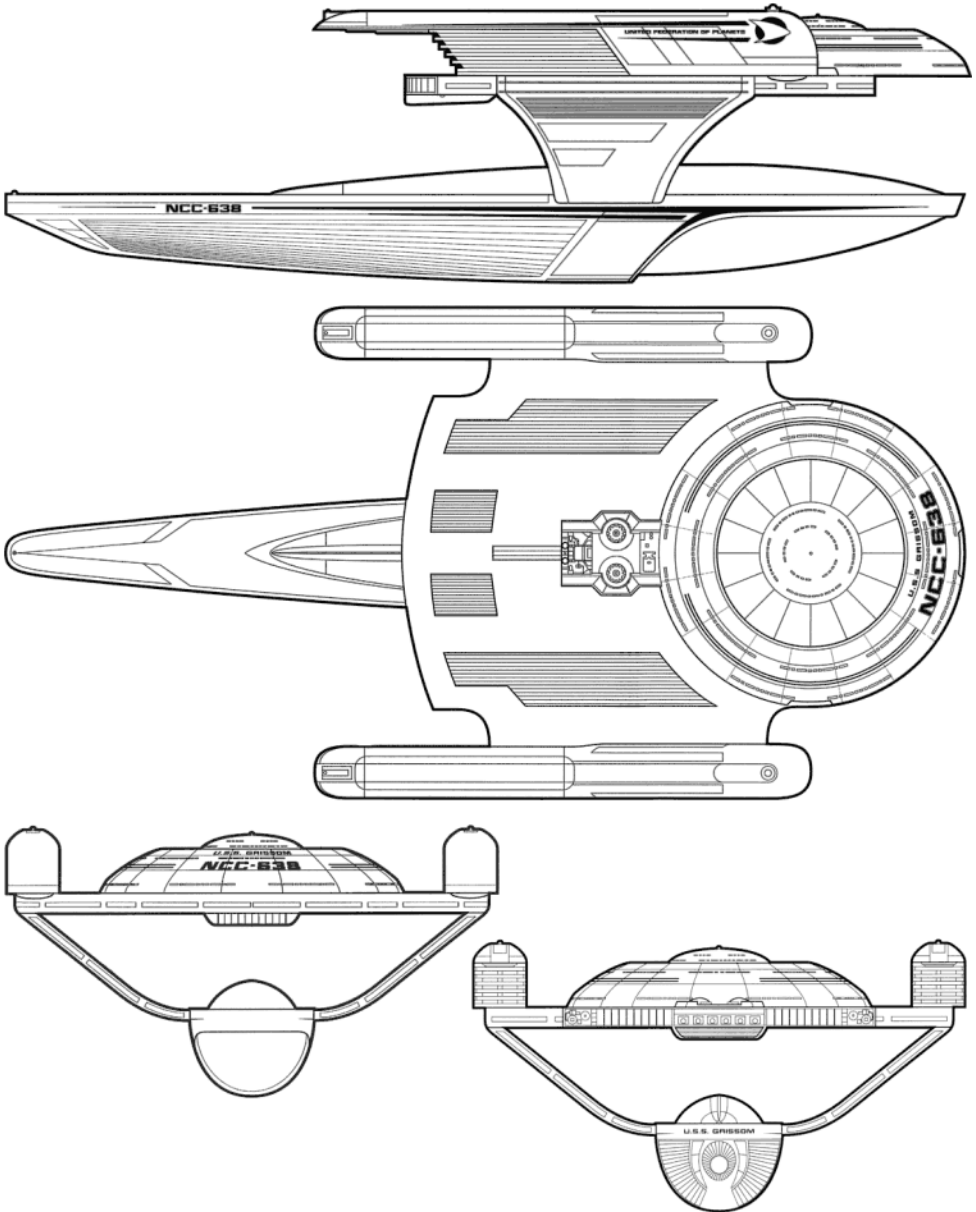

OLYMPIC CLASS

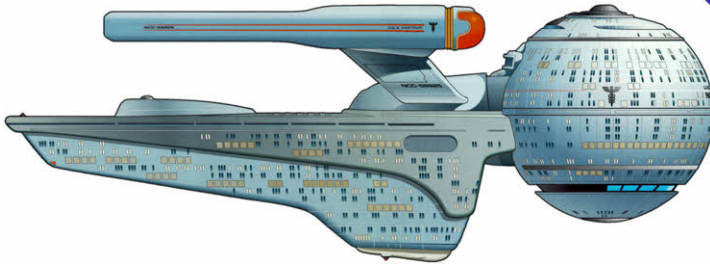

Class: Olympic
Type: Medical Frigate
Commissioned: 2366
Production Base: Marin County Starfleet Yards
Length: 320 metres
Beam: 150 metres
Height: 117 metres

Mass: 1,320,000 metric tons
Crew: 275
Cruising Speed: Warp 6
Maximum Speed: Warp 9
Armament: 2 Type X phaser arrays

NCC	Known Ships (USS)
	Hope
55012	Nobel
	Olympic
58925	Pasteur

CLASS INFORMATION:

The *Olympic*-class is the latest design in a lineage stretching back to the *Daedalus*-class of the 22nd century. Sometimes called Hospital Ships, these vessels have specific mission parameters and are commonly deployed behind the front lines during conflicts, such as in the Dominion War.

Olympic-class starships are relatively lightly armed and their crews are made up of a large proportion of doctors, nurses, triage medics and other medical technicians and specialists. As well as for relief efforts during wartime, *Olympic*-class vessels can be utilised during major medical emergencies and sudden disease outbreaks from the innermost Federation worlds out to the most distant colonies.

Many Hospital Ships are named after famous physicians of varied types through history, both from Earth and aligned worlds of the Federation.



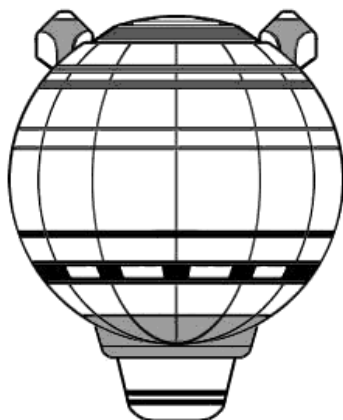
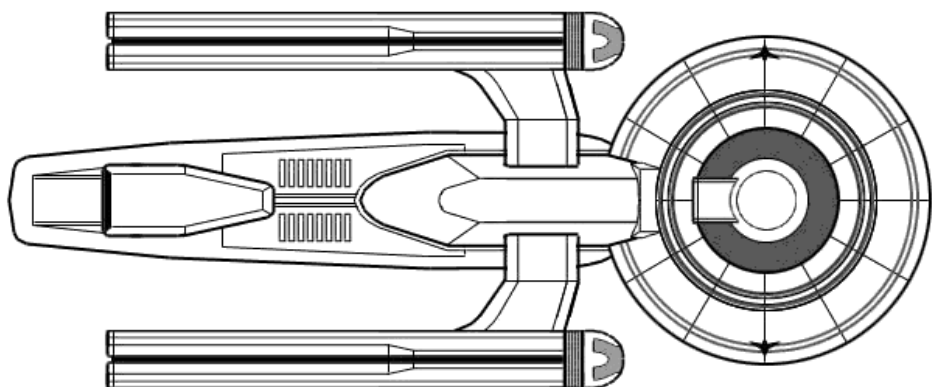
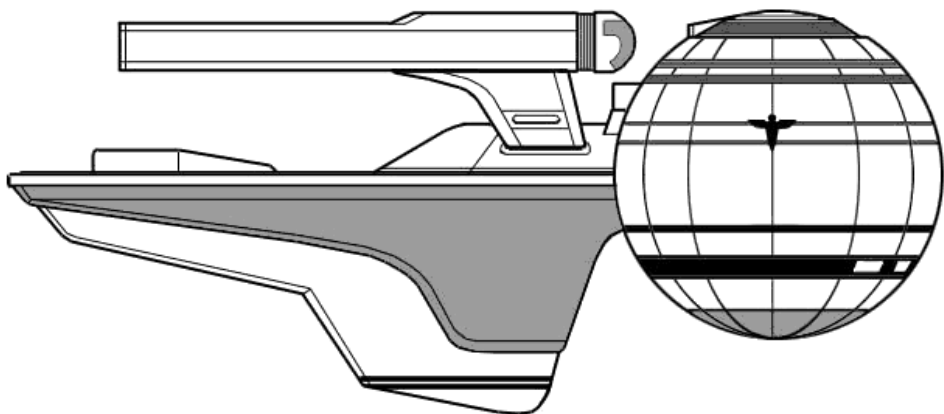

PROMETHEUS CLASS



Class: Prometheus

Type: Tactical Cruiser

Commissioned: 2374

Production Base: Beta Antares
Ship Yards, Antares Sector

Length: 415 metres

Beam: 170 metres

Height: 113 metres

Mass: 850,000 metric tons

Crew: 141

Cruising Speed: Warp 9

Maximum Speed: Warp 9.99

Armament: 13 Type XII phaser
arrays, 3 Mk 95 photon/quantum
torpedo launchers

NX Known Ships (USS)

59650 * Prometheus

* Redesignated as NX-74913
after Stardate 51461

CLASS INFORMATION:

Launched in 2374, the *Prometheus*-class starship represents the most advanced, cutting-edge design concept in the fleet. Designed for long-range tactical assignments, the *Prometheus* is a response to increasing threats to the Federation.

The *Prometheus*-class features a revolutionary 'multivector assault mode' allowing the vessel to separate into three warp-capable parts which can operate semi-independently. Other features include ablative armour, regenerative shielding, and a ship-wide holo-emitter array to allow the ship's Emergency Medical Hologram (EMH) to operate in all crew areas. The ship's control systems are so advanced, a crew of as few as four can operate the ship from the bridge.

The Romulan Tal Shiar unsuccessfully attempted to hijack the prototype on its first field-testing run.



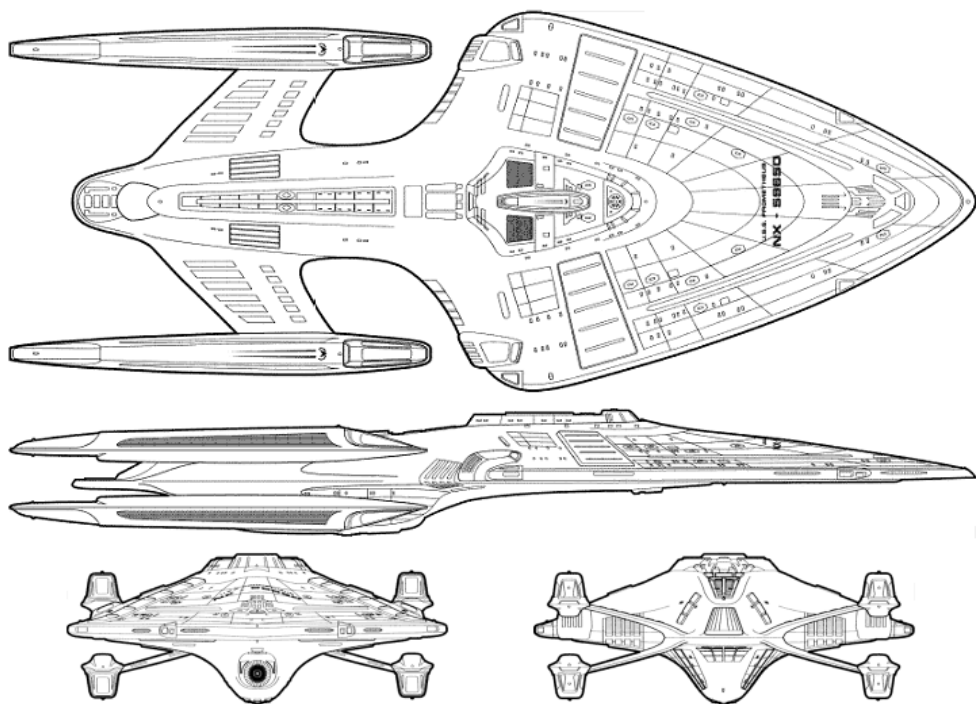

TACTICAL MULTI-VECTOR ATTACK SEPARATION



PTOLEMY CLASS

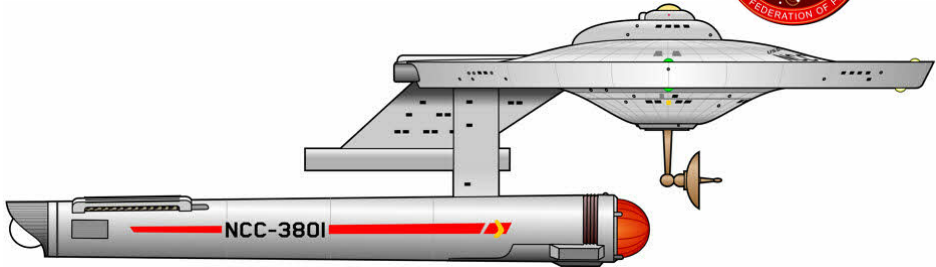

Class: Ptolemy
Type: Transport/Tug
Commissioned: 2245
Production Base: San Francisco Fleet Yards, Earth
Length: 222 metres
Beam: 127.1 metres
Height: 66 metres

Mass: 126,500 metric tons
Crew: 220
Cruising Speed: Warp 6 *
Maximum Speed: Warp 8 *
Armament: 3 Phaser banks

* *Original Cochrane Unit (OCU)*

NCC	Known Ships (USS)
3801	Ptolemy
3802	Al Rashid ϕ
	ϕ <i>Non-canon</i>

CLASS INFORMATION:

The *Ptolemy*-class was a transport/tug used by Starfleet during the 23rd century to transport priority military and government cargo and troops.

Based on the standard Starfleet design tree and hull components of the time, the *Ptolemy*-class replaced the engineering hull of the *Constitution*-class with a connector at the base of the neck, which could accept a variety of cylindrical transport containers. The *Ptolemy*-class could pull up to three containers towed in line.

Several types of container pod were available, optimised for bulk liquids, dry bulk, refrigeration, personnel, and other products. The starliner pod could carry up to 300 personnel, and was usually used to carry relief crews to isolated outposts. Freight pods were unmanned, but contained accessways for crew and station personnel to oversee loading and unloading.



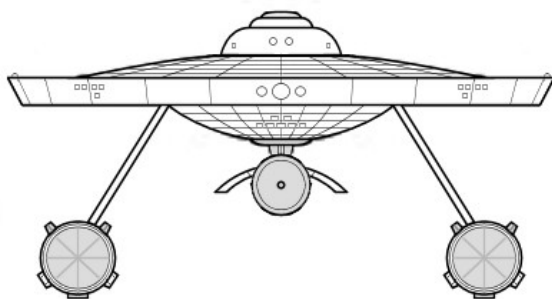
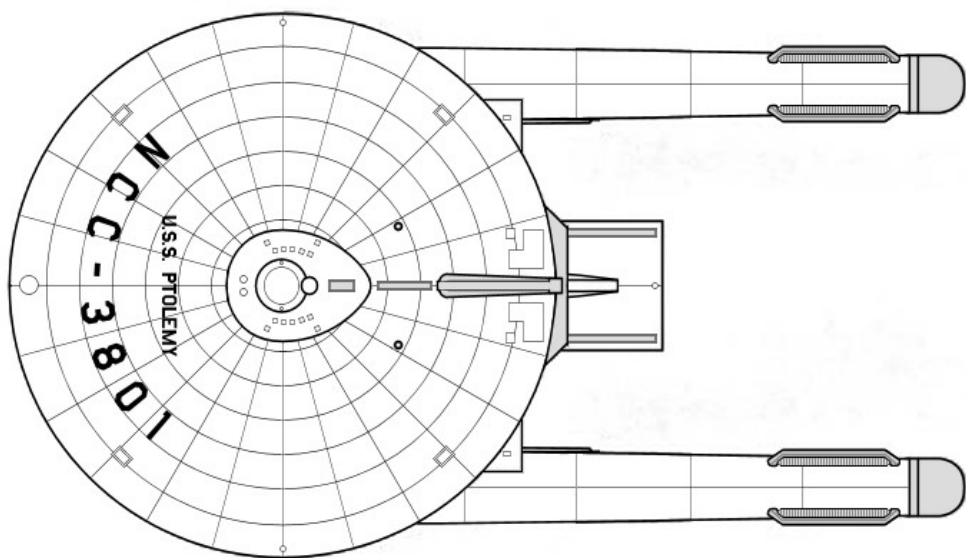
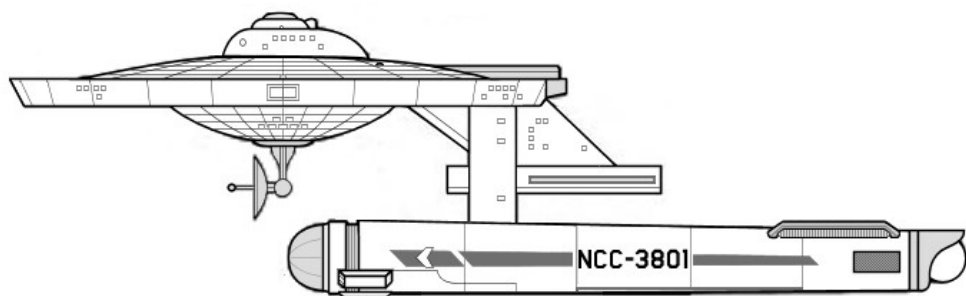

SABER CLASS



Class: Sabber
Type: Light Cruiser
Commissioned: 2370
Production Base: Spacedock One, Earth
Length: 223 metres
Beam: 227 metres
Height: 55 metres

Mass: 310,000 metric tons
Crew: 40
Cruising Speed: Warp 6
Maximum Speed: Warp 9.7
Armament: 4 Type X phaser arrays, 2 Mk 75 photon torpedo launchers

NCC	Known Ships (USS)
1941-A	Bozeman ϕ
81623	da Vinci ϕ
61956	Pearson Saber
61947	Yeager
	ϕ Non-canon

CLASS INFORMATION:

The *Sabber*-class starship was introduced in 2370 as part of Starfleet's initiative to create a new generation of ships to combat any future Borg incursions after the defeat at Wolf 359. Designed primarily for reconnaissance, patrol and escort duties, the *Sabber's* manoeuvrability and versatility make it a reliable combat vessel.

Twice the size of the *Defiant*-class, the *Sabber*-class shares many of the design features of its little sister, as well as of the larger *Steamrunner*-class. Its compact design allows it to maintain faster impulse speeds and turn more tightly than other, larger ships. The *Sabber* needs this speed, as its design features a weaker hull than other Starfleet vessels, and less shield power than most other ships. Nevertheless, *Sabber*-class vessels played a key role in repelling the second Borg incursion in 2373.



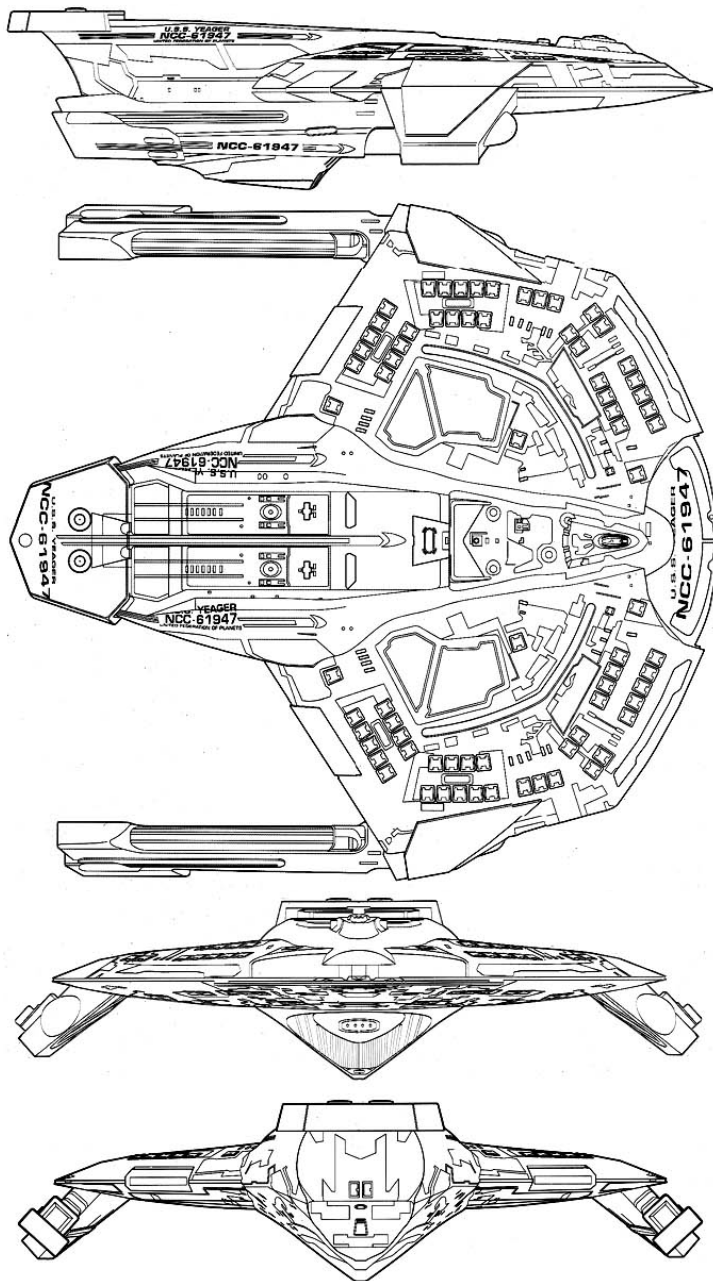

SALADIN/HERMES CLASS

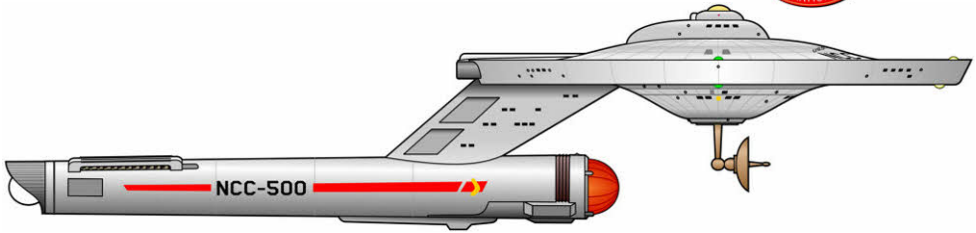

Class: Saladin/Hermes
Type: Destroyer/Scout
Commissioned: 2245
Production Base: San Francisco Fleet Yards, Earth
Length: 242.5 metres
Beam: 127.1 metres
Height: 60 metres

Mass: 95,000/94,500 metric tons
Crew: 200/195
Cruising Speed: Warp 6 *
Maximum Speed: Warp 8 *
Armament: Saladin: 3 Phaser banks, 2 photon torpedo launchers, Hermes: 1 Phaser bank
 * *Original Cochrane Unit (OCU)*

NCC	Known Ships (USS)
621	Columbia
585	Hermes
595	Revere
500	Saladin *

* *Saladin-class*

CLASS INFORMATION:

The *Saladin* and *Hermes*-classes were developed in parallel around the same time as the *Constitution*-class programme. Conceived as a smaller, more compact configuration using similar components, the *Saladin/Hermes* design features a single warp nacelle connected to a *Constitution*-class primary hull and dorsal.

The main difference between the two classes is the inclusion of two extra phaser banks and a photon torpedo tube for the *Saladin* - designated as a destroyer - compared to the *Hermes* - designated as a scout - which features just a single phaser bank.

Notable *Hermes*-class starships include the *U.S.S. Revere* NCC-595 and the *U.S.S. Columbia* NCC-621, which were ordered to rendezvous during the V'Ger crisis of 2273.



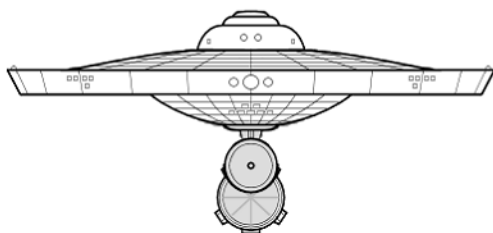
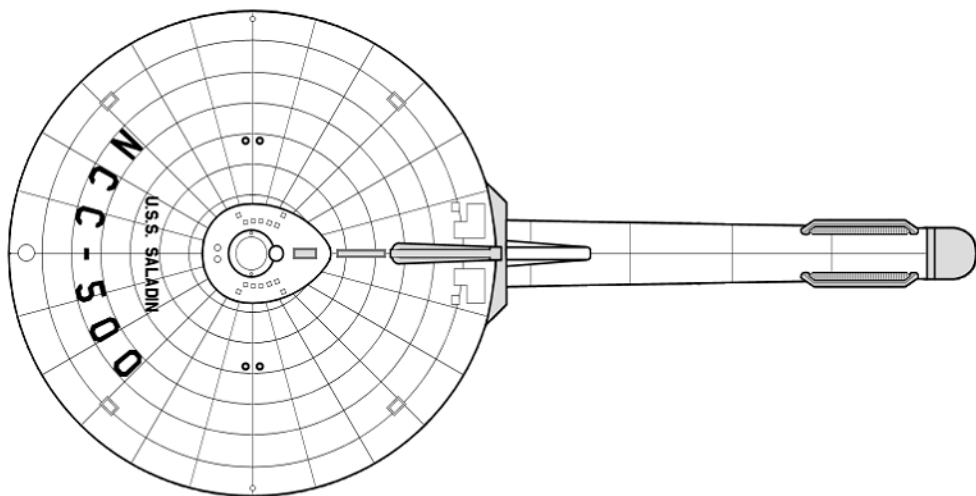
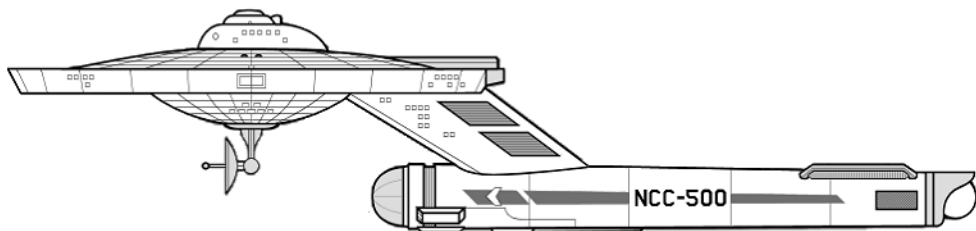

SHELLEY CLASS

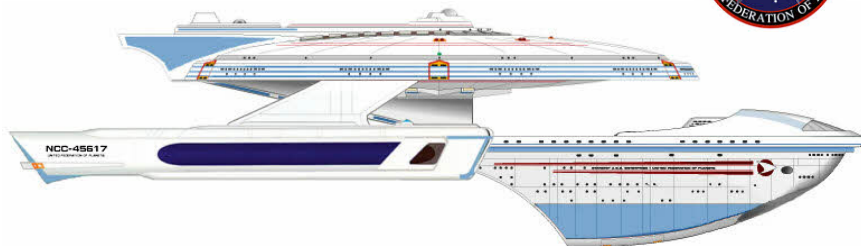

Class: Shelley

Type: Carrier/Transport

Commissioned: 2331

Production Base: Utopia
Planitia Fleet Yards, Mars

Length: 272 metres

Beam: 186 metres

Height: 76 metres

Mass: 1,270,000 metric tons

Crew: 290

Cruising Speed: Warp 6

Maximum Speed: Warp 9.75

Armament: 5 Type VIII phaser
banks, 4 Mk 70 photon torpedo
launchers

NCC **Known Ships (USS)**

42254 Curry

Shelley ϕ

42284 Raging Queen *

* Variant ϕ Non-canon

CLASS INFORMATION:

The *Shelley*-class is Starfleet's fighter carrier and troop transport, and as such is rarely seen in peace-time.

During *Excelsior* refit and upgrade programs in the early 2330s, various decommissioned *Excelsiors* were stripped, restructured, fitted with *Constitution*-class nacelles and modified to serve as carriers. These *Shelley*-class starships can carry up to 48 *Falcon* and *Peregrine* class fighters, and accommodate up to 6,000 troops.

The *Shelley*-class's secondary hull contains multi-tiered shuttle and fighter bays, plus troop barracks, and is able to be left on station if necessary, allowing the primary hull section of the ship to warp away.

There are two variants of the *Shelley*-class design in service, one with vertically aligned nacelles and the other with horizontally aligned ones. Ships of both sub-classes played key support roles for Starfleet throughout the Dominion War.



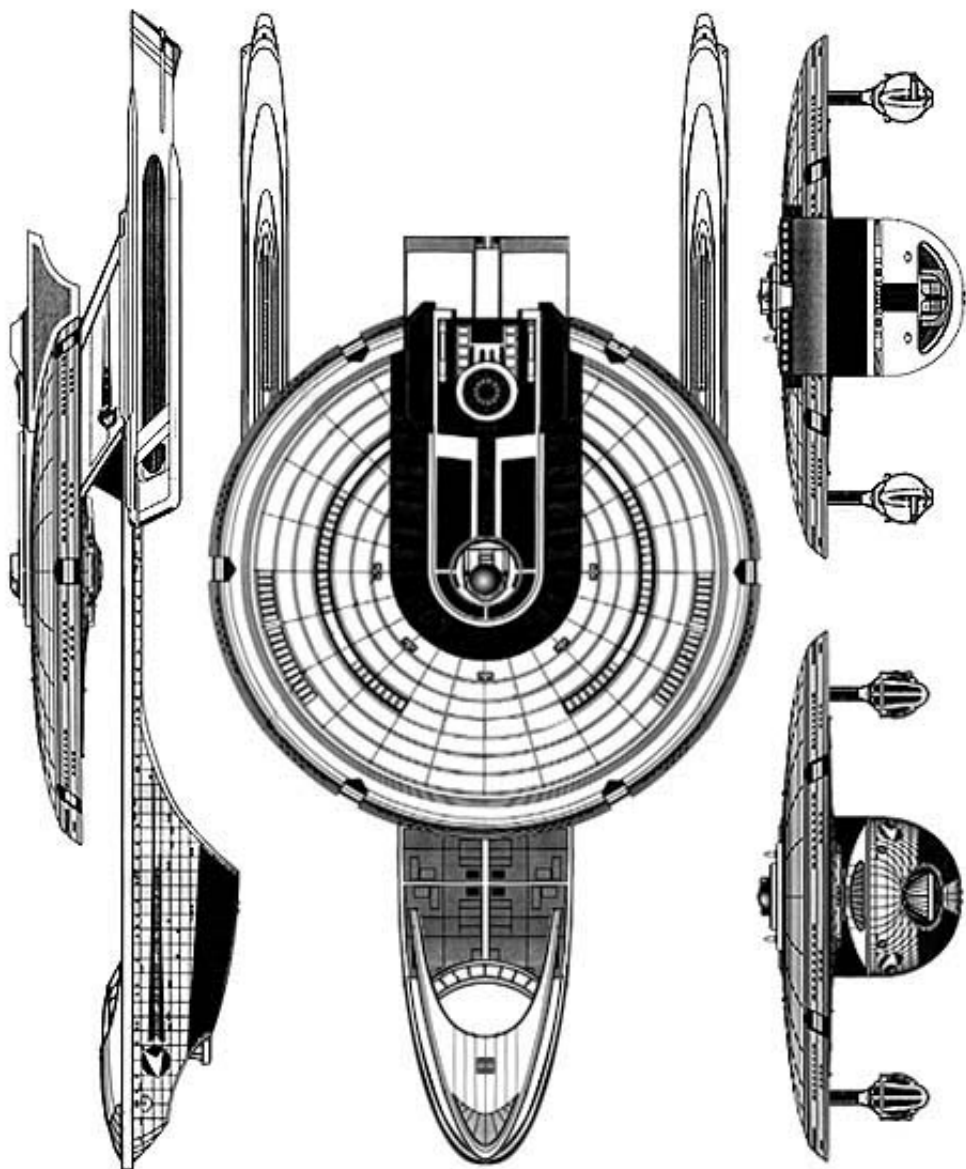

SHERMAN CLASS

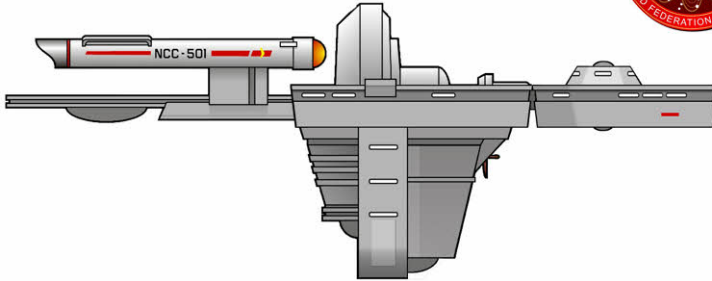

Class: Sherman
Type: Freighter/Cargo Drone
Commissioned: 2266
Production Base: Cameron Naval Centre, Deneb V & Orbital Station 2, Ursinus
Length: 163.4/125.1 metres
Beam: 58.65 metres

Height: 53.9 metres
Mass: 14,700 metric tons
Crew: 20/0
Cruising Speed: Warp 3
Maximum Speed: Warp 4.5
Armament: None

NCC	Known Ships
501	Antares †
G1400	Sherman *‡
325	Woden *†
330	Yorkshire
G1465	(Name unknown) *

* Automated variant
† Lost or destroyed
‡ Non-canon

CLASS INFORMATION:

The *Sherman*-class was a small freighter and transport vessel commonly used in the Federation during the 2260s.

The *Sherman* featured a removable forward crew module and bridge section, allowing it to be used for manned transport and survey missions or as an automated cargo drone. The holds were situated amidships above and below the main spaceframe. While smaller in size than a *Constitution*-class starship, overall the *Sherman*-class possessed a much larger cargo capacity.

Notable *Sherman*-class ships included the *Antares* NCC-501, commanded by Captain Ramart, which exploded after being psychokinetically sabotaged by former passenger Charlie Evans in 2266, and the *Woden* NCC-325, an unmanned ore freighter destroyed by the M-5 computer installed on the U.S.S. Enterprise in 2268.

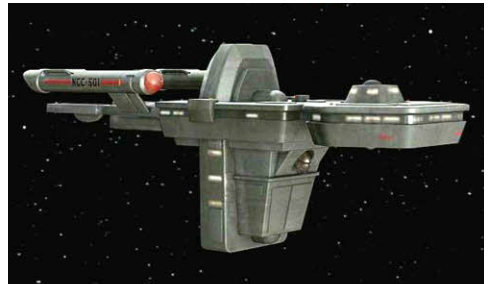

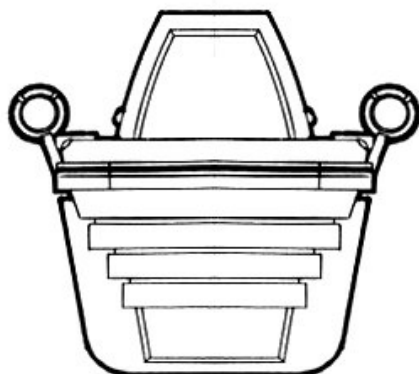
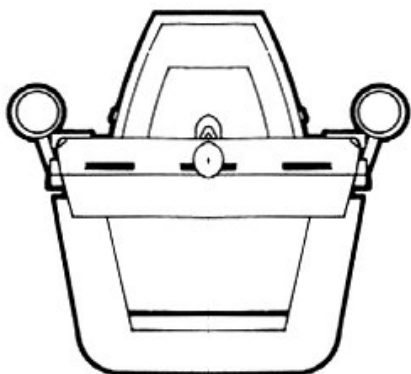
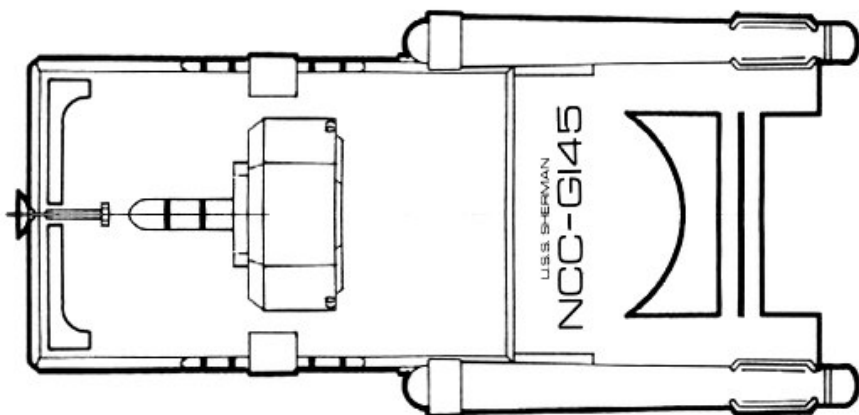
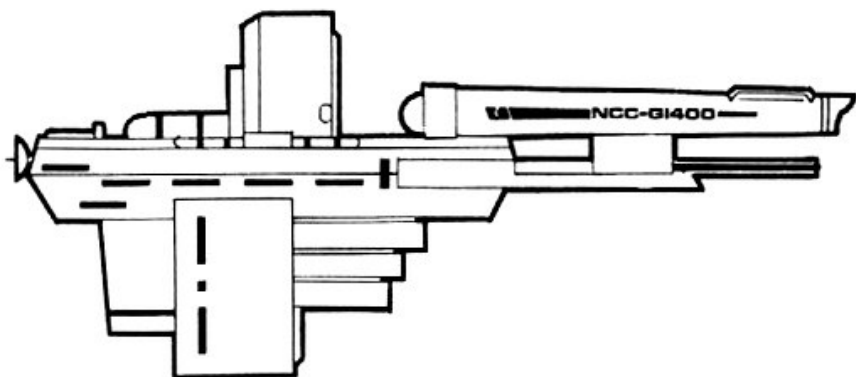

SOVEREIGN CLASS



Class: Sovereign
Type: Heavy Cruiser
Commissioned: 2369
Production Base: San Francisco Fleet Yards, Earth
Length: 685.3 metres
Beam: 250.6 metres
Height: 88.2 metres

Mass: 3,205,000 metric tons
Crew: 855
Cruising Speed: Warp 6
Maximum Speed: Warp 9.99
Armament: 16 Type XII phaser arrays, 8 Mk 95 photon torpedo launchers, 1 Mk 95 quantum torpedo launcher

NCC **Known Ships (USS)**
1701-E Enterprise
73811 Sovereign

CLASS INFORMATION:

The *Sovereign*-class is Starfleet's replacement for the venerable *Excelsior*-class. Designed as a multi-function vessel effective for long-range exploration and combat, the *Sovereign* is equipped with advanced weapons and upgraded sensor and shield systems.

Work on the class began in 2365, but Starfleet's defeat by the Borg at Wolf 359 a year later prompted the Advanced Starship Design Bureau (ASDB) to make tactical upgrades to the design. The spaceframe has no large dorsal between the saucer and engineering hulls, augmenting structural integrity. It also features a modified warp drive that will not harm the fabric of space, which is now standard throughout the fleet. The bottom of the saucer houses a warp-capable captain's yacht.

The prototype *U.S.S. Sovereign* NX-73811 was commissioned in 2369, with the *U.S.S. Enterprise* NCC-1701-E - the flagship of the Federation - following in 2372.



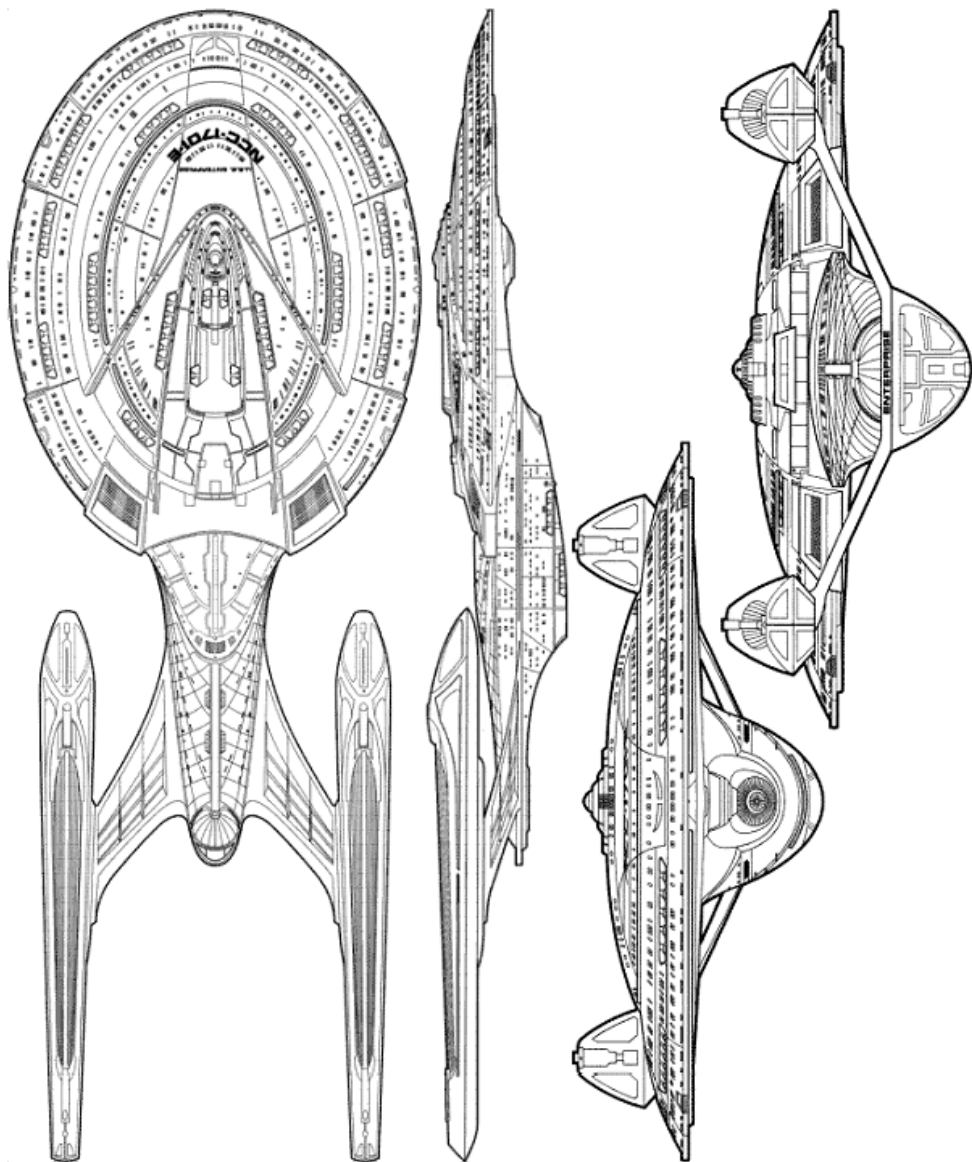

SOYUZ CLASS

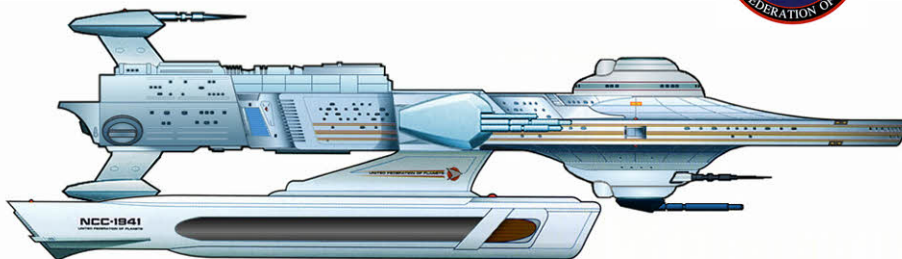

Class: Soyuz
Type: Border Cutter
Commissioned: 2270
Production Base: Starbase 12
Length: 241.38 metres
Beam: 148.06 metres
Height: 60.86 metres
Mass: 230,000 metric tons

Crew: 40
Cruising Speed: Warp 5
Maximum Speed: Warp 8.8
Armament: 6 Type VII phaser banks, 2 phaser turrets, 2 Mk 22 photon torpedo launchers

NCC	Known Ships (USS)
1941	Bozeman Soyuz

CLASS INFORMATION:

The *Soyuz*-class was a border patrol ship from the mid to late 23rd century, whose missions included servicing remote outposts and policing spaceways.

The *Soyuz* featured an innovative set of outboard sensor and phaser turrets, designed for the ship's Neutral Zone patrol duties. However, due to limited resources and the only partial success of the experimental configuration, the *Soyuz*-class was withdrawn from service in 2288 in favour of its smaller yet more versatile cousin, the *Miranda*-class.

The most famous *Soyuz*-class ship is the *U.S.S. Bozeman* NCC-1941, commanded by Captain Morgan Bateson. The *Bozeman* was caught in a temporal loop near the Typhon Expanse in 2278. The ship was freed 90 years later and reinstated into Starfleet. Its crew took part in the battle which repelled the Borg incursion of 2373.

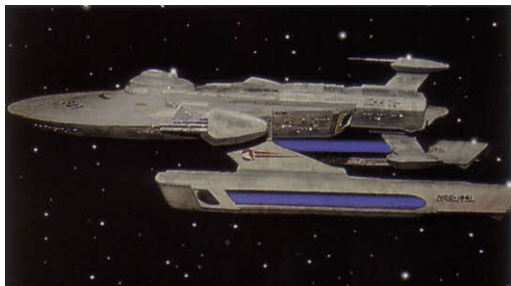

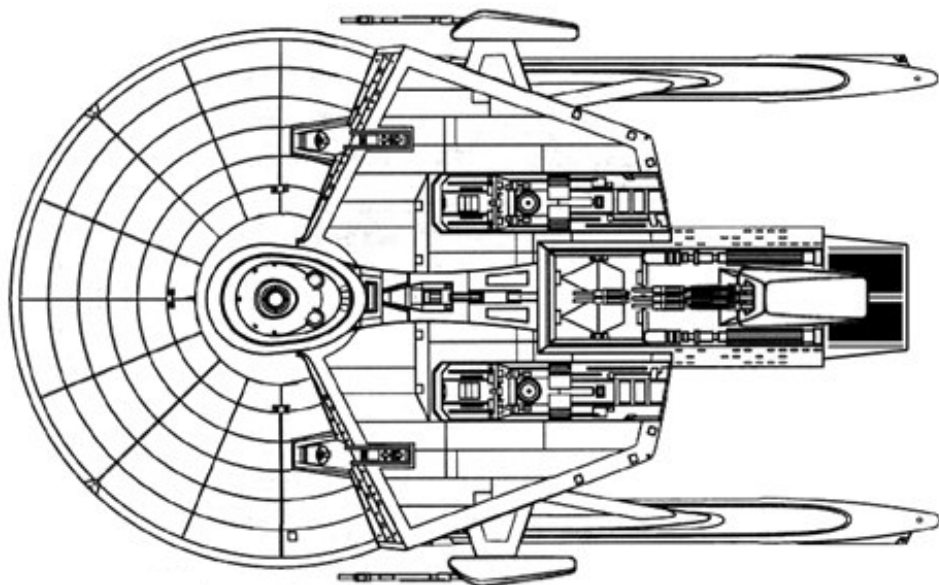
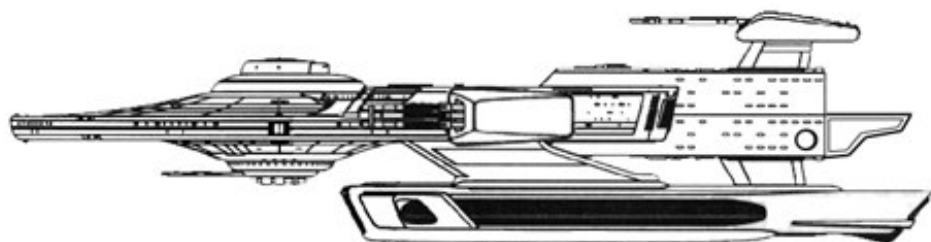

SPRINGFIELD CLASS

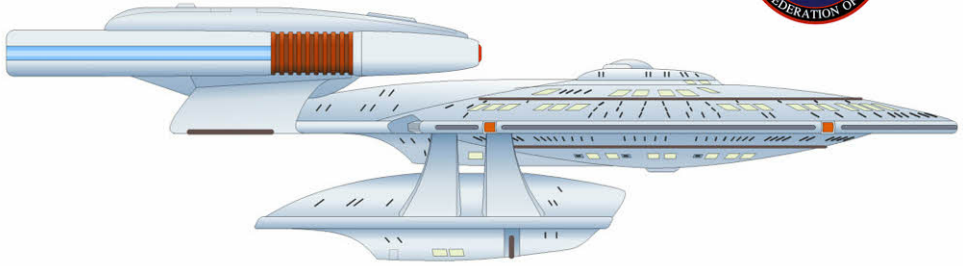

Class: Springfield
Type: Surveyor
Commissioned: 2352
Production Base: San Francisco Fleet Yards, Earth
Length: 323 metres
Beam: 265 metres
Height: 88 metres

Mass: 850,000 metric tons
Crew: 120
Cruising Speed: Warp 6
Maximum Speed: Warp 9.2
Armament: 5 Type IX phaser arrays, 2 Mk 75 photon torpedo launchers

NCC **Known Ships (USS)**
57302 Chekov †
 Springfield
† *Lost or destroyed*

CLASS INFORMATION:

The *Springfield*-class is a relatively small vessel primarily used as a surveyor. However, the class is highly configurable and as such can have fairly versatile deployment details.

The *Springfield* is a forerunner of the *Nebula*-class design, with which it shares the distinctive mission adaptable pod feature. Much smaller and less capable than the *Nebula*, the *Springfield* is intended to operate over shorter ranges. The *Springfield* features two removable pods. The upper module is frequently used for sensor equipment or cargo, while the lower secondary hull module provides additional laboratory space if needed.

The *Springfield*-class U.S.S. *Chekov* NCC-57302 was one of the thirty-nine ships lost in battle against the Borg at Wolf 359 in 2366-67.



SPRINGFIELD CLASS
THE FRO DOORWAY
WWW.TREKMANIA.NET



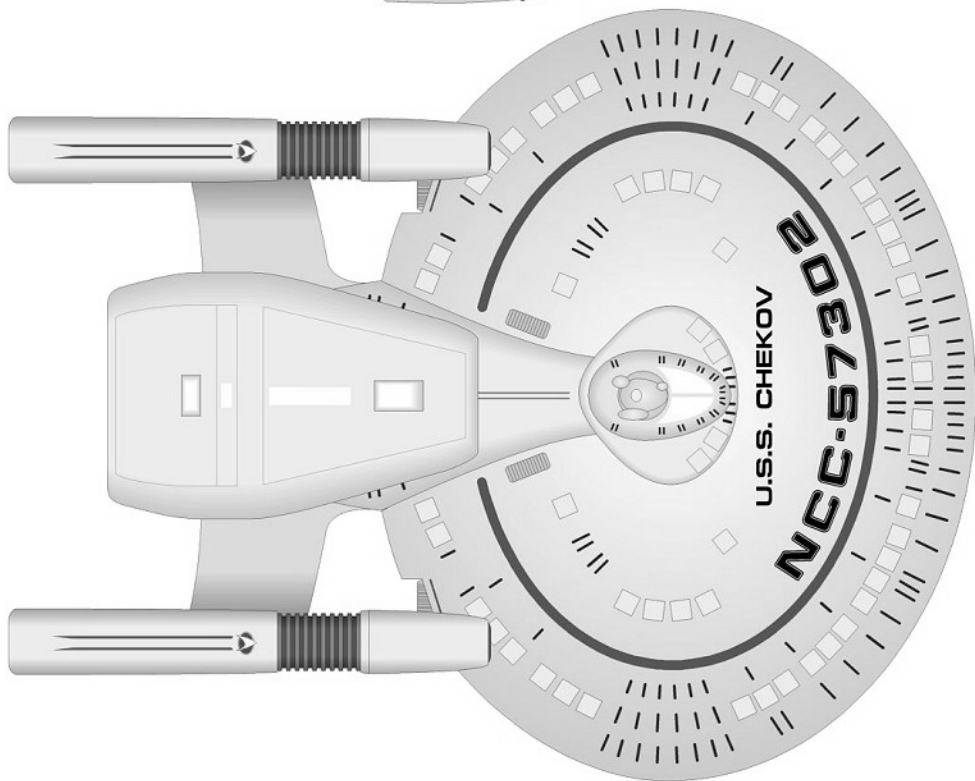
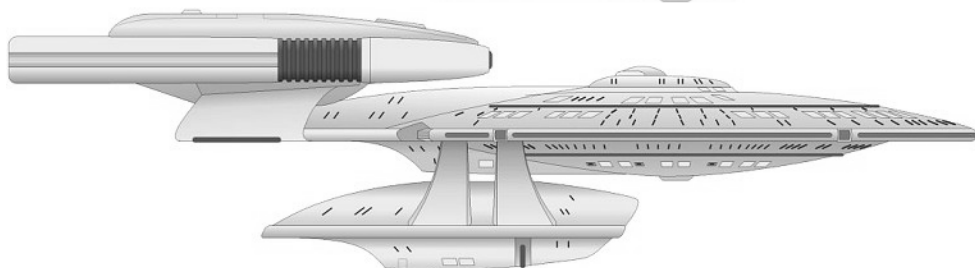
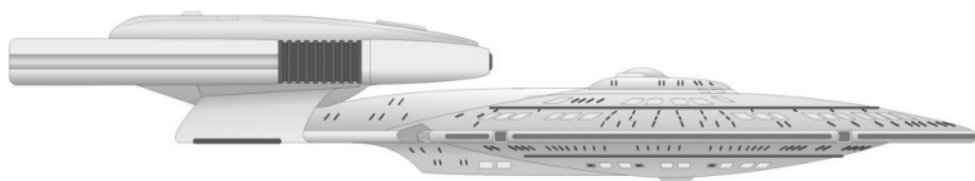

STEAMRUNNER CLASS



Class: Steamrunner
Type: Frigate
Commissioned: 2371
Production Base: Antares & Utopia Planitia Fleet Yards
Length: 356 metres
Beam: 262 metres
Height: 59 metres

Mass: 889,000 metric tons
Crew: 270
Cruising Speed: Warp 6
Maximum Speed: Warp 9.7
Armament: 6 Type X phaser arrays, 2 Mk 75 photon torpedo launchers

NCC	Known Ships (USS)
52136	Appalachia
52133	Cavor
59015	Hiroshima †
52142	Menehune Steamrunner

† Lost or destroyed

CLASS INFORMATION:

The *Steamrunner*-class went into production in 2371 as part of Starfleet's response to the Dominion's larger, disposable Jem'Hadar fleets, and the continuing Borg threat. The ship's mission profile includes perimeter patrol and defence, long-range threat response, covert operations and combat support.

Like the *Akira*-class, the *Steamrunner* features a large through-saucer shuttlebay. As well as standard photon torpedoes, the *Steamrunner*-class can be armed with high-yield tri-cobalt torpedoes, effective as long-range artillery.

The *Steamrunner*-class, along with its contemporary the *Saber*-class, pioneers a new, compact mounting of the warp nacelles directly into the primary hull, rather than on traditional pylons. This new design feature is made possible thanks to improvements in radiation shielding technology, allowing the ship's crew increased protection from the warp field generators.



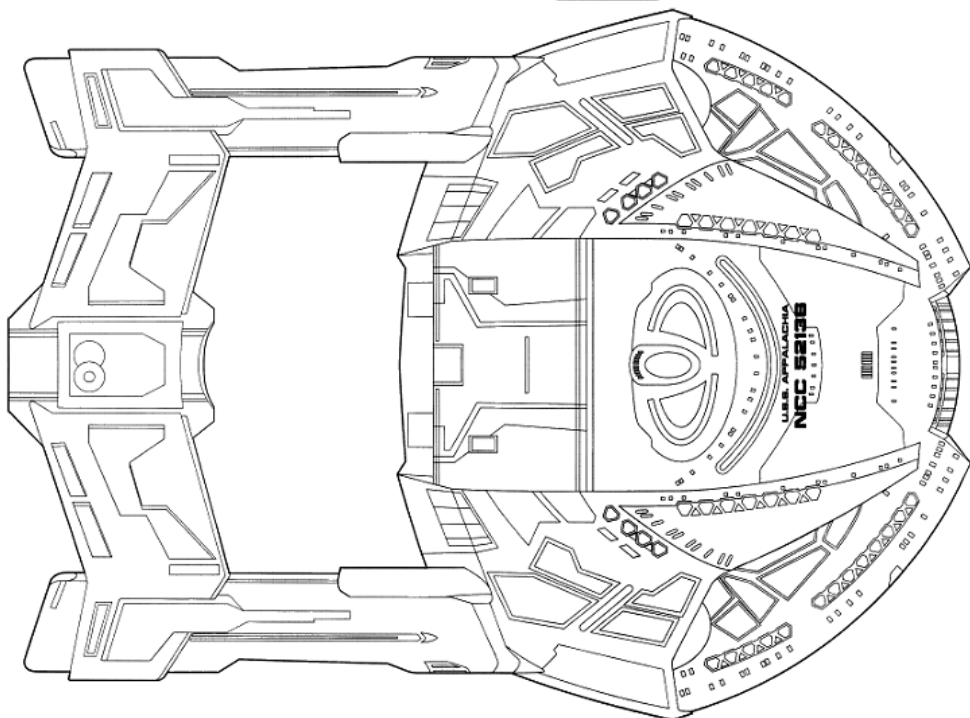
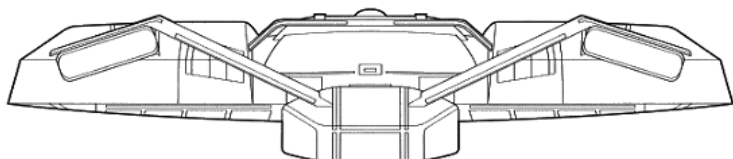
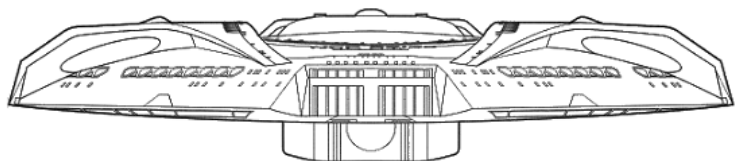
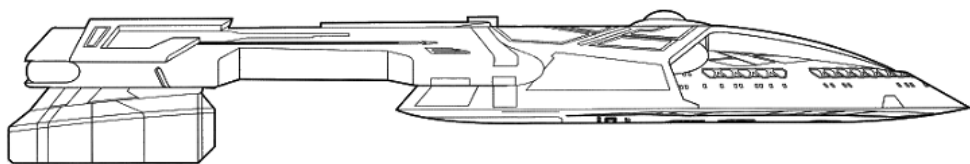

SYDNEY CLASS

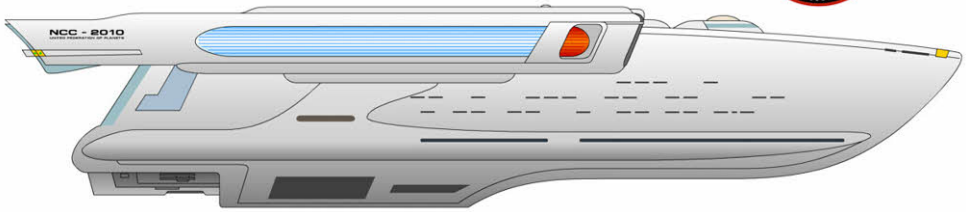

Class: Sydney
Type: Transport
Commissioned: 2284
Production Base: San Francisco Fleet Yards, Earth
Length: 235 metres
Beam: 125 metres
Height: 42 metres

Mass: 360,000 metric tons
Crew: 125
Cruising Speed: Warp 5
Maximum Speed: Warp 8.5
Armament: 2 Type VII phaser banks

NCC	Known Ships (USS)
2010	Jenolan †
2010-5	Nash Sydney
	† Lost or destroyed

CLASS INFORMATION:

Sydney-class starships are relatively large transport vessels which employ similar bridge modules and the same warp nacelles as the *Constitution* and *Miranda*-classes.

The *Sydney*-class is similar in design to several other transport ships from this and other eras, such as the later *Wambundu*-class. Though principally deployed as a personnel transport, the *Sydney* can also be used for long-range colonial transport and cargo haulage.

The *U.S.S. Jenolan* NCC-2010 disappeared in 2294 and was presumed lost. It was not discovered until 2369 that the *Jenolan* had crashed into a Dyson Sphere, and that one passenger, Captain Montgomery Scott, had survived for 75 years by suspending himself in an modified transporter beam. The ship was later destroyed while helping the *U.S.S. Enterprise-D* escape from inside the Sphere.



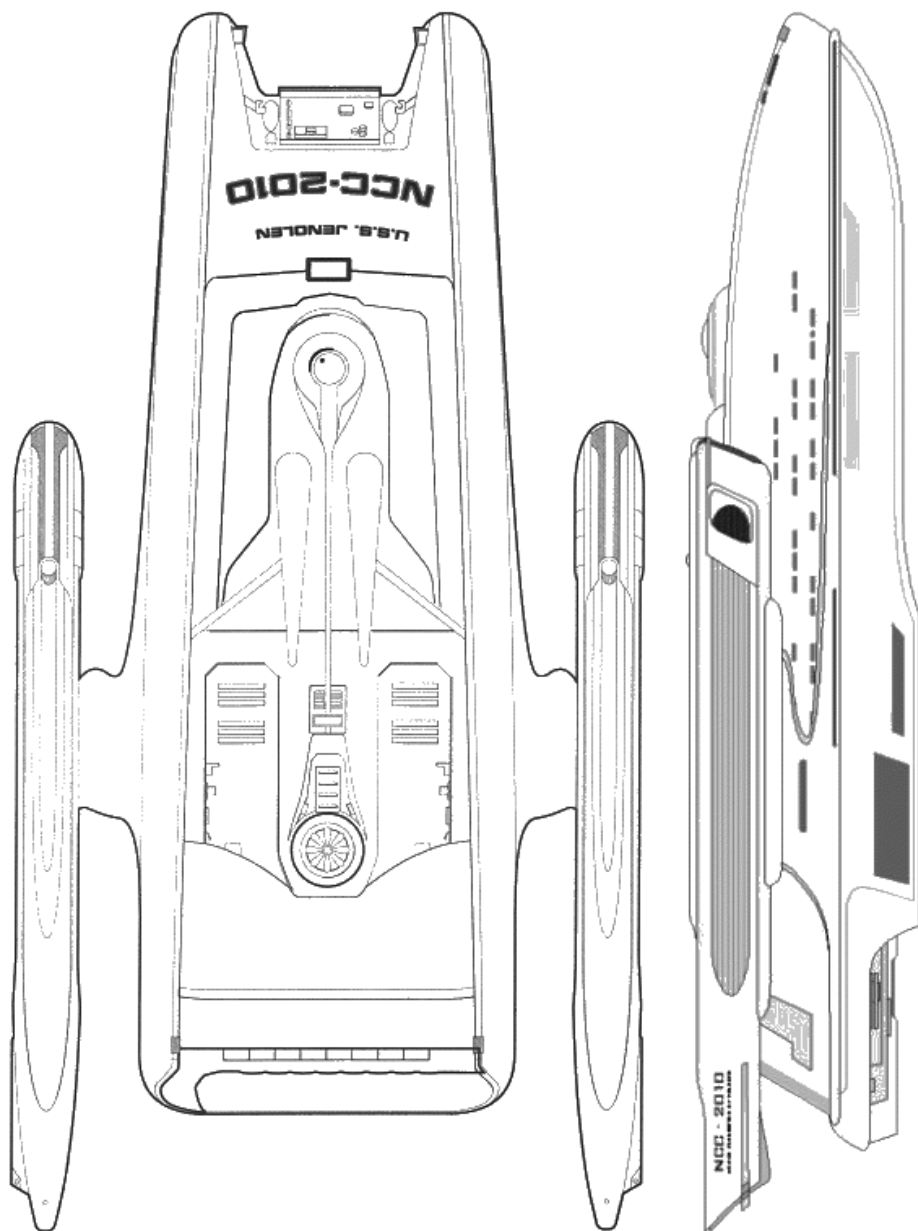



**EARTH &
FEDERATION
CIVILIAN
STARSHIPS**

CLASS III FREIGHTER

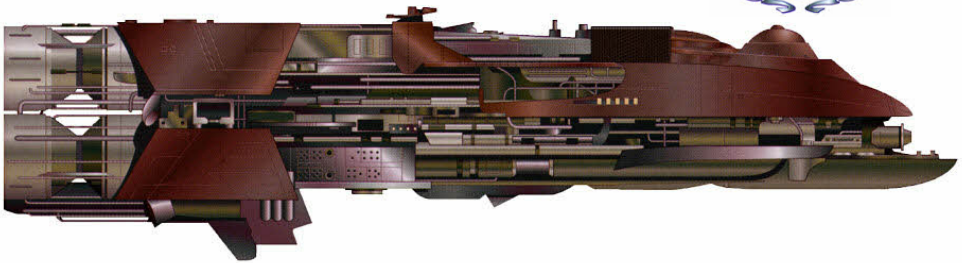

Class: Class III/Merchantman
Type: Transport
Commissioned: 2240
Production Base: Antares Shipyards & Merimar Ship Works, Rigel IV
Length: 150 metres
Beam: 99.6 metres

Height: 42.9 metres
Mass: 50,000 metric tons
Crew: 75
Cruising Speed: Warp 4
Maximum Speed: Warp 6
Armament: None

Known Ships
Bok'Nor †
Merchantman †
† *Lost or destroyed*

CLASS INFORMATION:

The *Class III* freighter is a common sight along Federation trade routes, as well as in the Cardassian Union and the Klingon Empire. The *Class III* can transport goods, fuel and passengers in bulk, servicing homeworlds, colonies and distant outposts alike. The *Class III* is unarmed, but does possess a navigational shield grid that can provide limited resistance to attack. The Cardassian variant of this type of vessel was constructed out of kelindide and rhodium.

In 2285, the *S.S. Merchantman* carried classified Federation data regarding the Genesis Device to a Klingon Bird-of-Prey under the command of Kruge. The *Merchantman* was destroyed when Kruge learned that Valkris, a Klingon operative travelling aboard the freighter, had seen the information. A Cardassian *Class III* freighter, the *Bok'Nor*, was blown up by the Maquis in 2370 after they suspected it to be transporting weapons to arm Cardassian colonists in the Demilitarised Zone.



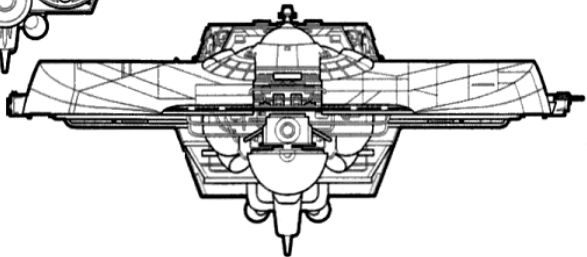
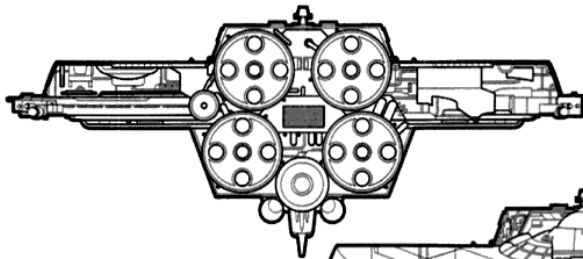
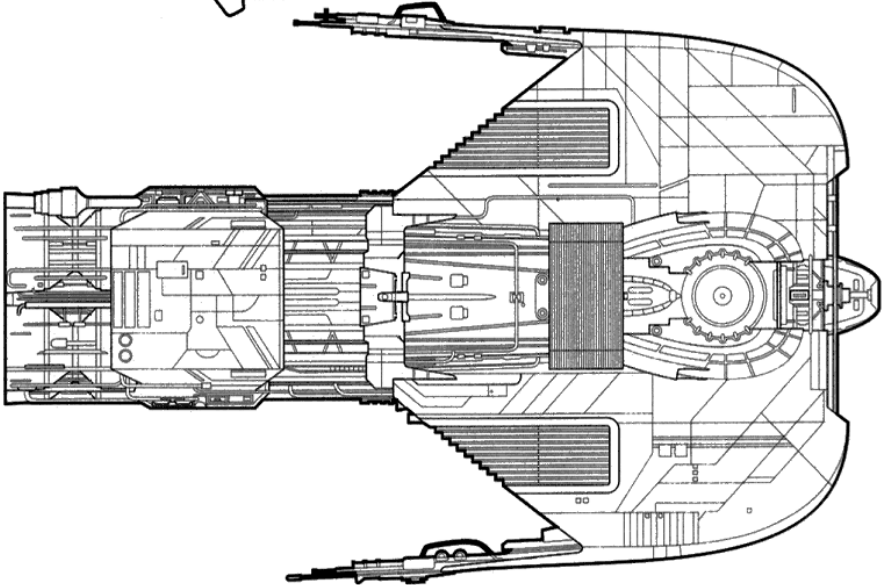
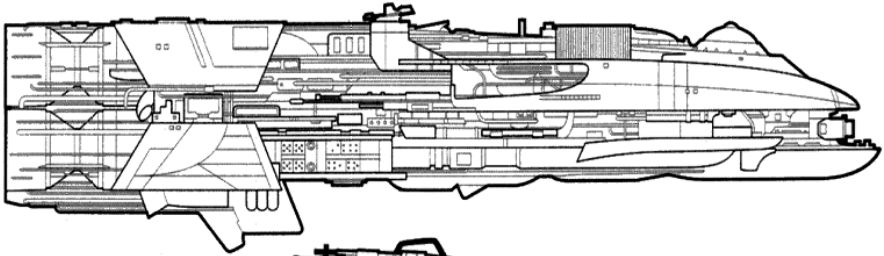

CONESTOGA

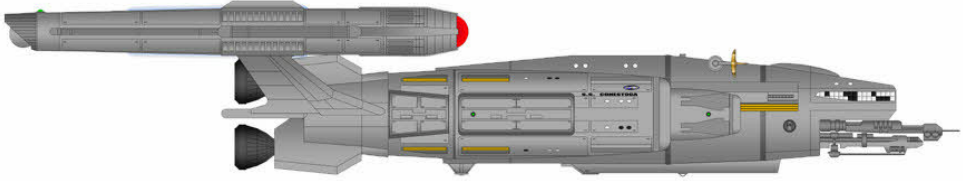

Class: Conestoga
Type: Colony Ship
Commissioned: 2069
Production Base: Unknown, Earth
Length: 180 metres
Beam: 67 metres
Height: 33 metres

Mass: 10,000 metric tons
Crew: 25 (plus 200 colonists)
Cruising Speed: Warp 1.3
Maximum Speed: Warp 1.4
Armament: 2 Plasma cannons

Known Ships (SS)
Conestoga

CLASS INFORMATION:

The S.S. *Conestoga* was an Earth colony ship built shortly after Zefram Cochrane's first warp flight, for the colonization of Terra Nova, a nearby class M planet. It was capable of carrying around two hundred colonists, and was equipped for long-term travel. The expedition was the first Human extra-solar colony effort.

The ship was specially constructed so that it could be dismantled on arrival to serve as homes and service buildings for the colony. The *Conestoga* was commanded by Captain Mitchell.

Launched in 2069, the *Conestoga* took nine years, travelling at Warp 1.3, to reach Terra Nova. The *Conestoga* reached the planet on June 23rd 2078, and its modules were dismantled to form the colony's initial structures.

The *Conestoga* inspired the design of the later *Discovery*-class United Earth scout ships of the mid-22nd century.



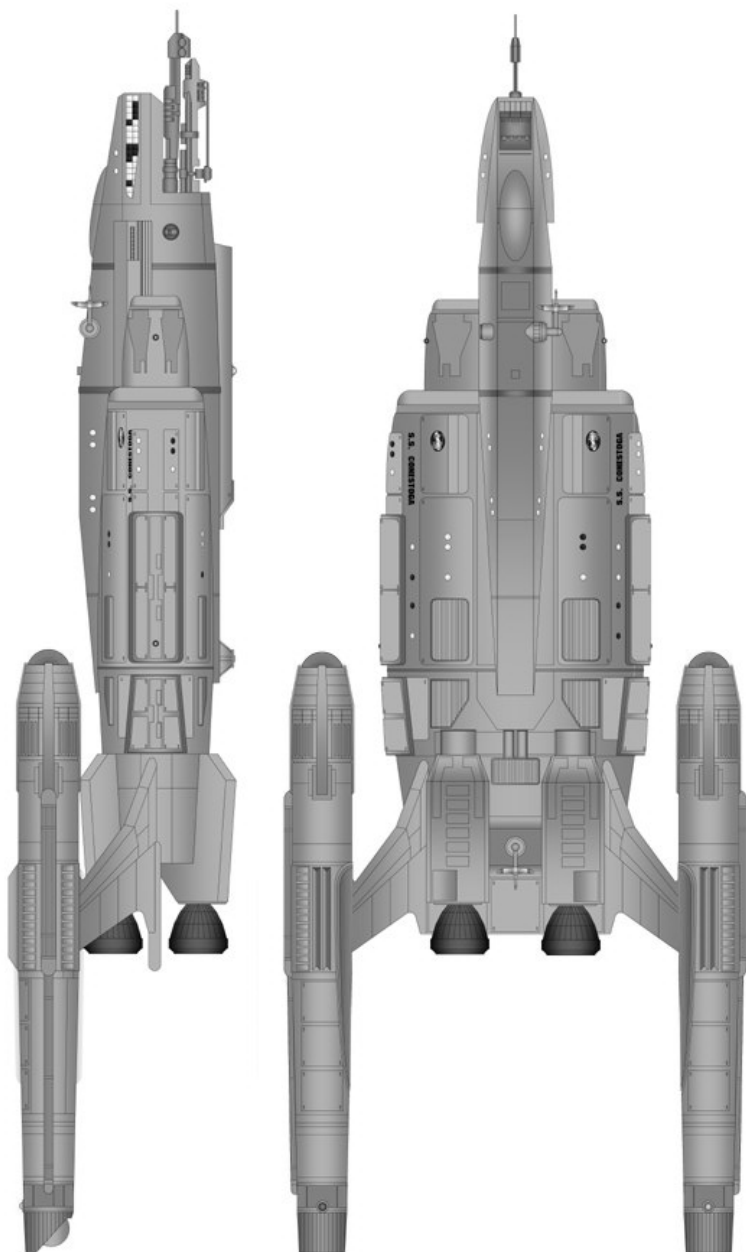

DY-100 CLASS

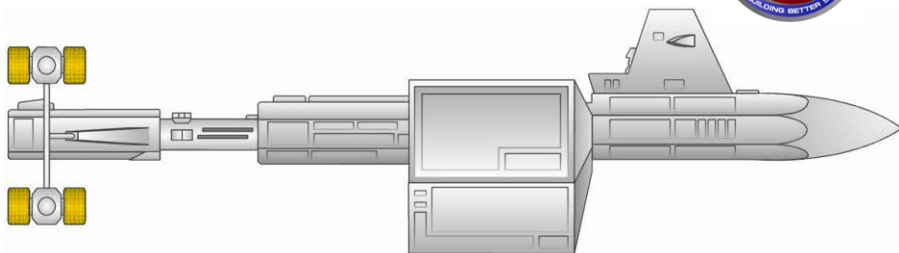

Class: DY-100
Type: Interplanetary Freighter
Commissioned: 1996
Production Base: Unknown, Earth
Length: 107.59 metres
Beam: 32.31 metres
Height: 48.77 metres

Mass: 21,100 metric tons
Crew: 85
Cruising Speed: Sublight
Maximum Speed: 0.2 c
Armament: None

DY Known Ships (SS)
DY-102 Botany Bay †
Copernicus ☿
DY-116 Woden †
† Lost or destroyed
☿ Non-canon

CLASS INFORMATION:

The *DY-100* class was an early Earth interplanetary vessel from the late 20th century. The *DY-100* was launched into orbit with booster rockets, then used simple nuclear powered engines once in space. They were equipped with artificial gravity, but still used transistors as components. Up to sixteen wedge-shaped cargo modules could be fitted around the spine of the vessel, with five as standard.

At least some *DY-100* vessels were sleeper ships. In these the crew were placed in suspended animation inside life support canisters prior to liftoff. Overall life support was then turned off for the journey. The use of suspended animation was necessary up to around 2018.

The *DY-100* class S.S. *Botany Bay*, carrying the former dictator Khan Noonien Singh and a group of his followers, was found adrift in the Mutara Sector in 2267 by the U.S.S. *Enterprise*. Khan and his augments were resettled to Ceti Alpha V.

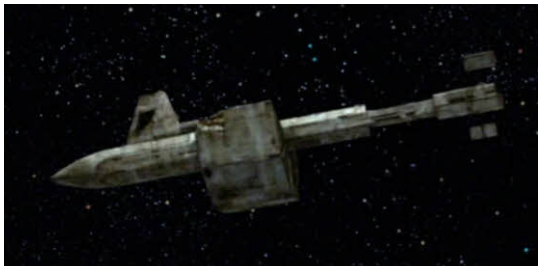

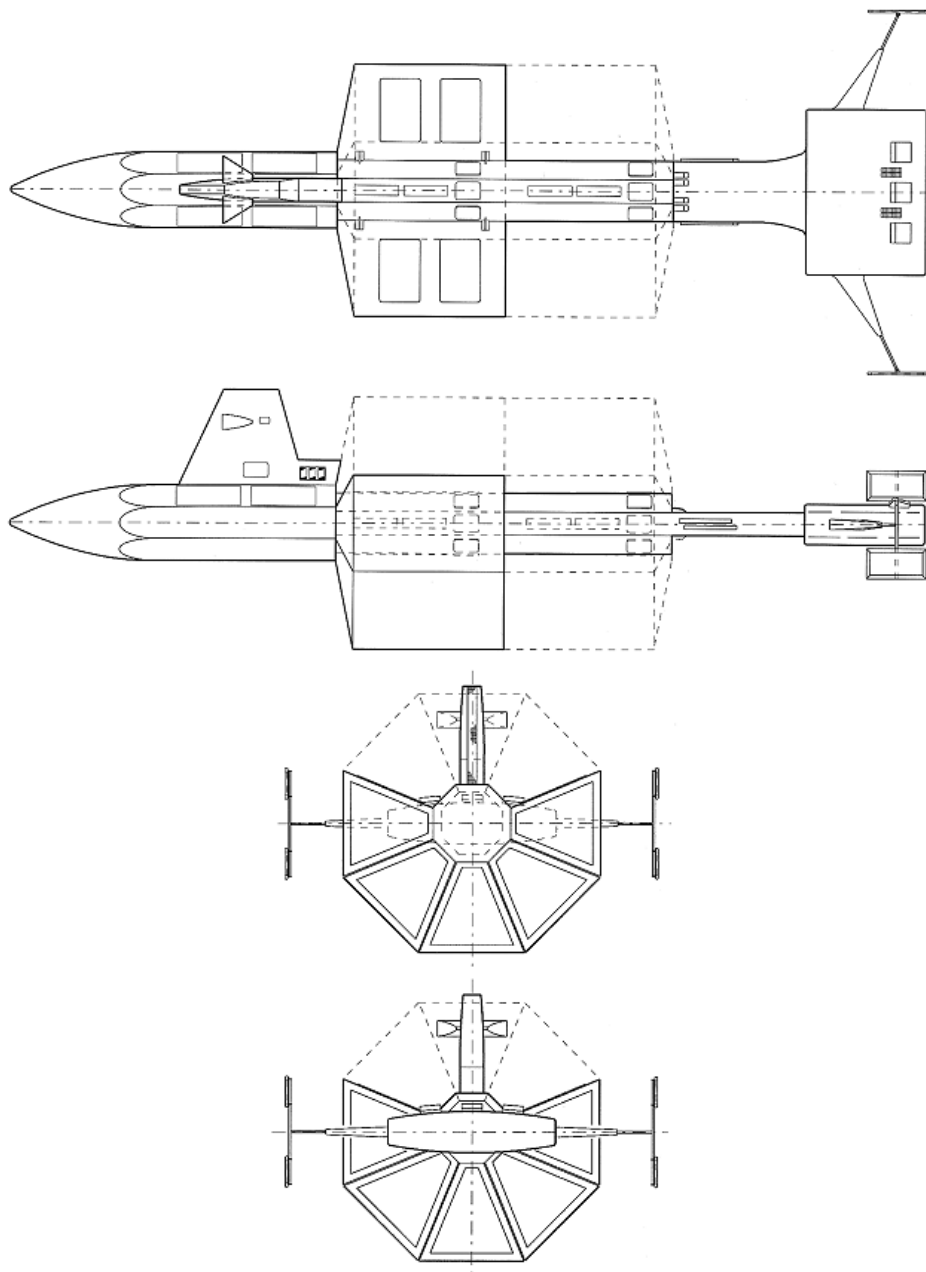

EARTH J CLASS



Class: J
Type: Freighter
Commissioned: 2102
Production Base: Earth
Length: 230 metres
Beam: 74 metres
Height: 38 metres
Mass: 855,000 metric tons

Crew: 15
Cruising Speed: Warp 1.5
Maximum Speed: Warp 2
Armament: 2 Plasma cannons

Known Ships (ECS)
Constellation
Horizon
North Star †
† *Lost or destroyed*

CLASS INFORMATION:

The *J-class* modular freighter was commonly used by the Earth Cargo Service through the first half of the 22nd century. It featured a small accommodation module and two side-mounted nacelles, with up to five cargo pods attached behind.

The *J-class* was well-armed for its size, with two plasma cannons for defence against pirates, and when detached from its cargo pods was very manoeuvrable. Interstellar voyages could take years or even decades, so these freighters were usually crewed by families. By the 2150s *J-class* freighters had a maximum speed of warp two, and were capable of hauling loads of up to 30,000 metric tons.

In 2152, the *Enterprise NX-01* transported Ensign Mayweather to see his family aboard the *Horizon* following the death of his father, the former captain. During his visit the vessel was attacked by pirates which Mayweather helped to fight off.

The *J-class* would eventually be superseded by the larger *Y-class*.

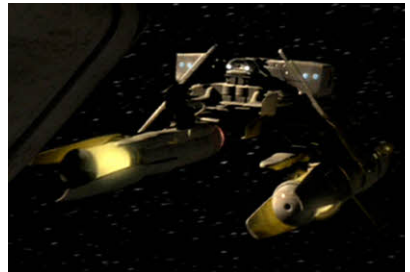

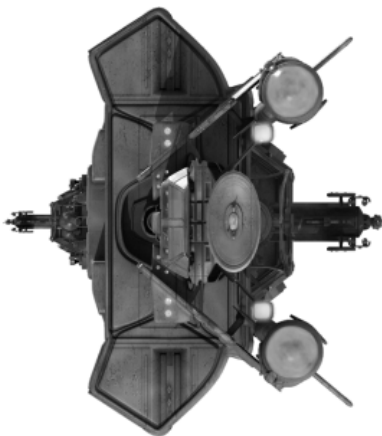
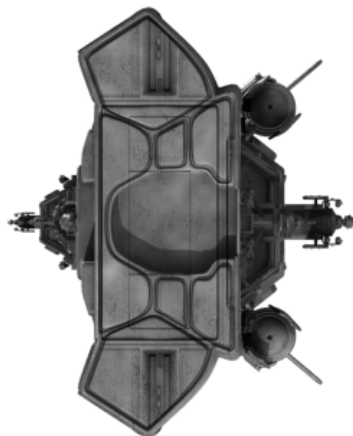
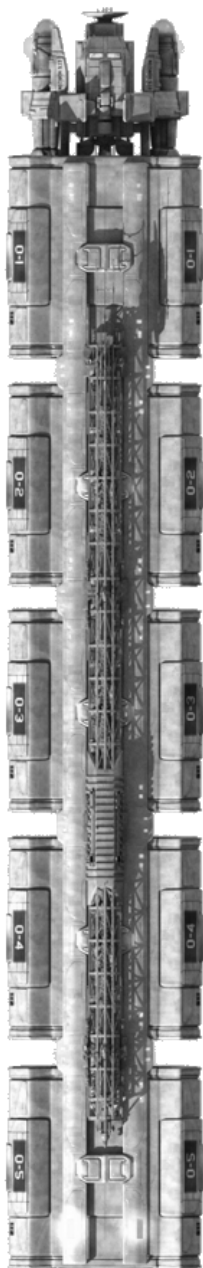

EARTH Y CLASS



Class: Y
Type: Freighter
Commissioned: 2114
Production Base: Earth
Length: 270 metres
Beam: 79 metres
Height: 49 metres
Mass: 634,000 metric tons

Crew: 23
Cruising Speed: Warp 1.5
Maximum Speed: Warp 1.8
Armament: 1 Plasma cannon

ECS **Known Ships (ECS)**
2801 Fortunate
 Ticonderoga †
† *Lost or destroyed*

CLASS INFORMATION:

The *Y-class* succeeded the *J-class* as one of Earth's most common freighters in the mid-22nd century. The modular design consisted of a long spine with the bridge and crew accommodation at the bow. Up to eight cargo modules could be attached to the sides of the backbone allowing for over twenty kilotons of freight. The warp nacelles were inboard of the cargo pods near the aft end of the ship.

The *Y-class* was lightly armed, with only a single plasma cannon as standard. Most captains had their weapons upgraded to defend against pirates.

In 2151, the *Enterprise NX-01* encountered the *Y-class* Earth Cargo Ship *Fortunate*, commanded by Captain Keene and his first officer Ryan, who were under attack from Nausicaan pirates.



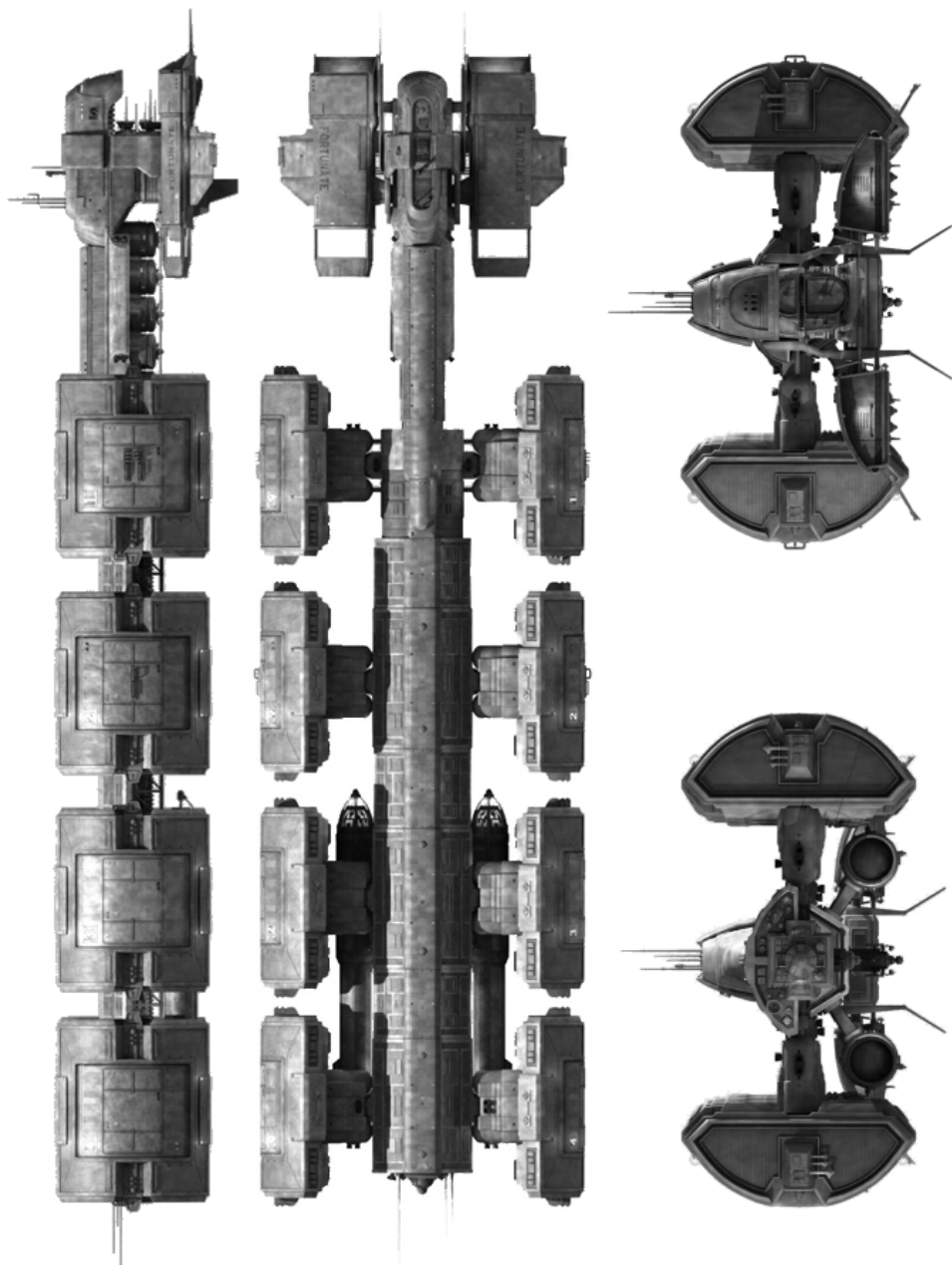

MAQUIS RAIDER

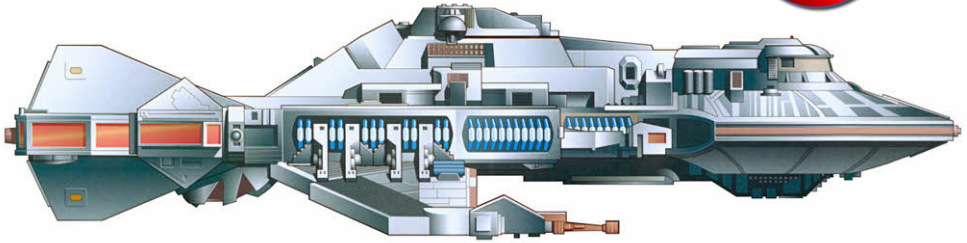

Class: Ju'day
Type: Attack Fighter/Courier
Commissioned: 2332
Production Base: Various
Length: 60 metres
Beam: 66 metres
Height: 14.6 metres
Mass: 2,600 metric tons

Crew: 2-4 (plus 50 passengers)
Cruising Speed: Warp 5
Maximum Speed: Warp 7
Armament: 2 Type V phaser banks, 4 photon torpedo launchers

Known Ships (SS)
Alpha Nine
Alpha Seven
Ju'day
Val Jean *†
* *Variant*
† *Lost or destroyed*

CLASS INFORMATION:

The *Ju'day*-class raider was a relatively small, manoeuvrable starship of Federation design, which was later used by the Maquis in their fight against the Cardassians.

At least two variants of the vessel existed. One version had a small cockpit with seating for two, and a cargo area in the aft section. The second variant featured a separate and much more spacious cockpit which held four stations, and larger crew facilities in the aft sections. Both designs were armed with twin wingtip-mounted phasers, and pairs of forward and aft firing torpedo launchers.

In 2371, the Maquis raider *Val Jean* was dragged across the galaxy by the being known as 'The Caretaker'. The ship was subsequently destroyed ramming a Kazon vessel, and its remaining personnel integrated into the crew of the *U.S.S. Voyager*.

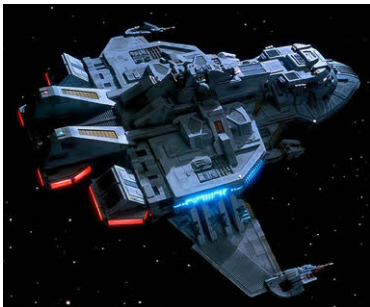

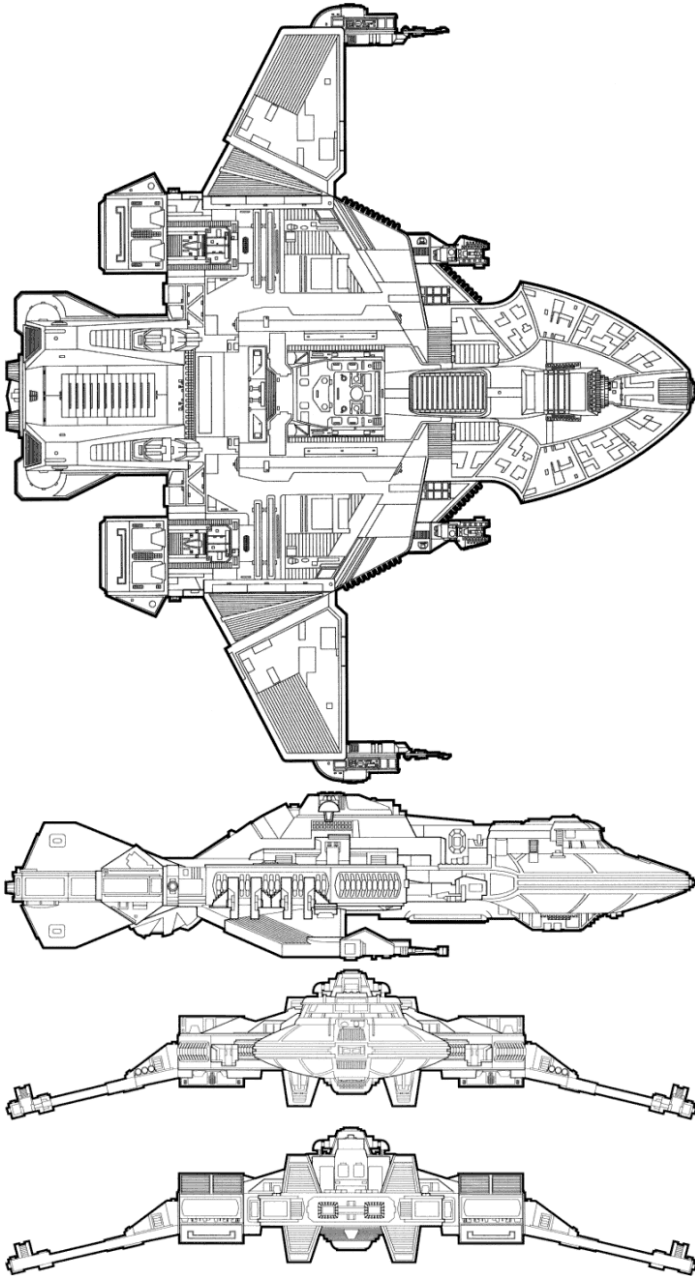

PHOENIX

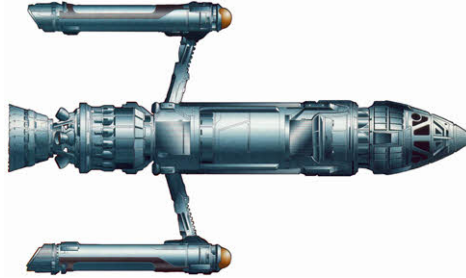

Class: Phoenix
Type: Prototype Warp Ship
Commissioned: 2063
Production Base: Bozeman,
Montana, Earth
Length: 27.5 metres
Beam: 16 metres
Height: 3.4 metres

Mass: 80 metric tons
Crew: 3
Cruising Speed: Sublight
Maximum Speed: Warp 1
Armament: None

Known Ships
Phoenix

N.B. Top view shown above

CLASS INFORMATION:

The *Phoenix* was Earth's first manned spacecraft to achieve the speed of light with warp drive. The *Phoenix* was built by space pioneer Dr. Zefram Cochrane and engineer Lily Sloane, inside a missile silo in Bozeman, Montana. It was mounted on a Titan V nuclear missile, and had a four metre titanium-cased cockpit and twin warp nacelles.

The *Phoenix* made its historic first warp flight on April 5th 2063, piloted by Zefram Cochrane. The flight attracted the attention of a passing Vulcan ship, the *T'Polana-Hath*, and the Vulcans initiated Humanity's first official contact with extraterrestrials.

The *Phoenix* was later placed on display at the Smithsonian Institution, and was the subject of a course taught at Starfleet Academy.

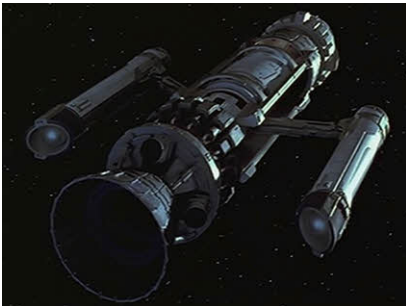

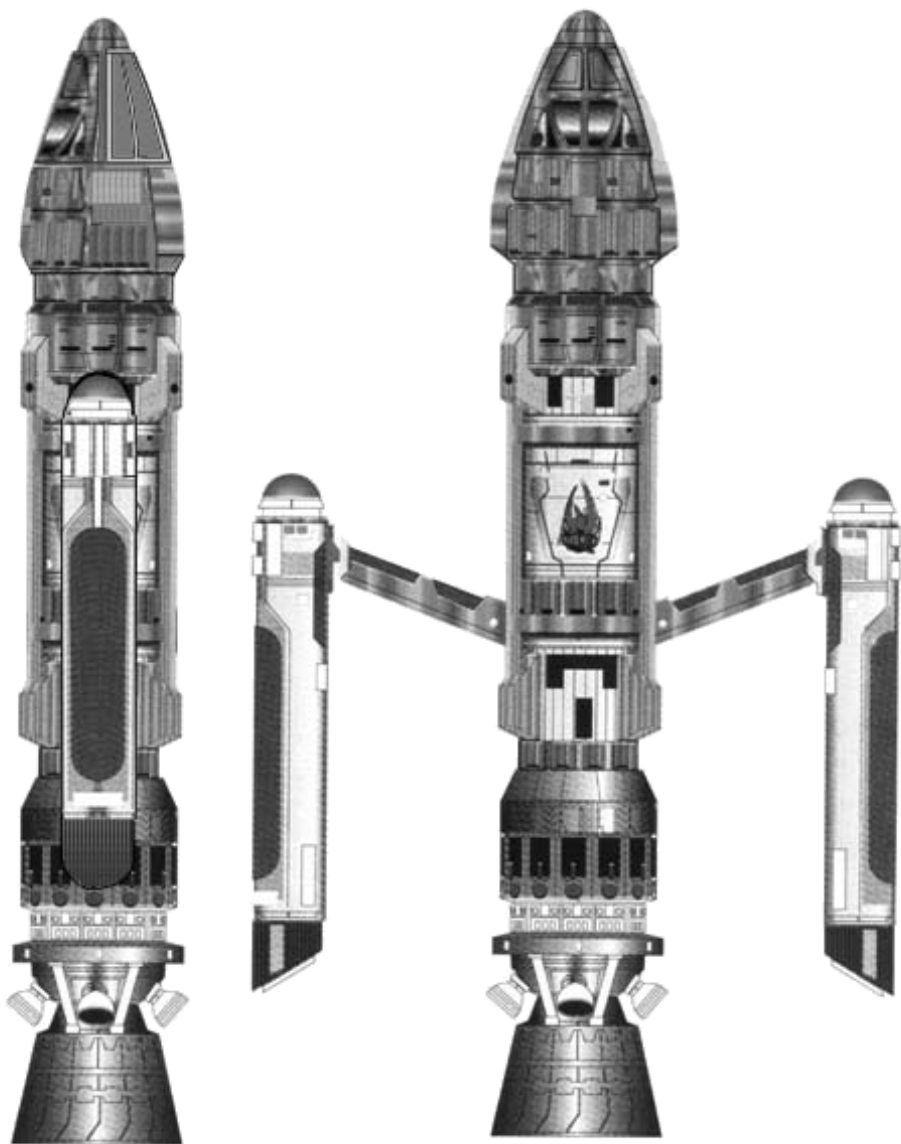

WHORFIN CLASS

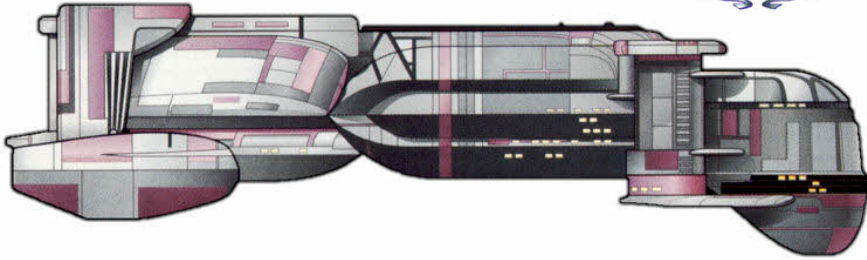

Class: Whorfin
Type: Transport
First Encountered: 2293
Production Base: Unknown
Length: 270 metres
Beam: 247 metres
Height: 80 metres
Mass: 420,000 metric tons

Crew: 15 (plus 200 passengers)
Cruising Speed: Warp 3
Maximum Speed: Warp 4
Armament: None

NFT	Known Ships (SS)
7793	Lakul †
1327	Robert Fox †
1024	Whorfin (U.S.S.) *

* *Starfleet ship (NCC registry)*
† *Lost or destroyed*

CLASS INFORMATION:

The *Whorfin*-class was a type of transport ship used by the Federation in the late 23rd century. It was capable of carrying upwards of 200 passengers. The class used TPS pulse fusion engines.

In 2293, two civilian *Whorfin*-class starships transporting El Aurian refugees, the *S.S. Lakul* NFT-7793 and the *S.S. Robert Fox* NFT-1327, were caught in the Nexus energy ribbon three light years from Earth. The *U.S.S. Enterprise* NCC-1701-B answered their distress call and managed to rescue 47 passengers from the *Lakul* before hull stresses destroyed both ships.

Starfleet also used *Whorfin*-class vessels, and the prototype *U.S.S. Whorfin* NCC-1024 was assigned to patrol the Neutral Zone at the time Operation Retrieve was proposed earlier the same year.



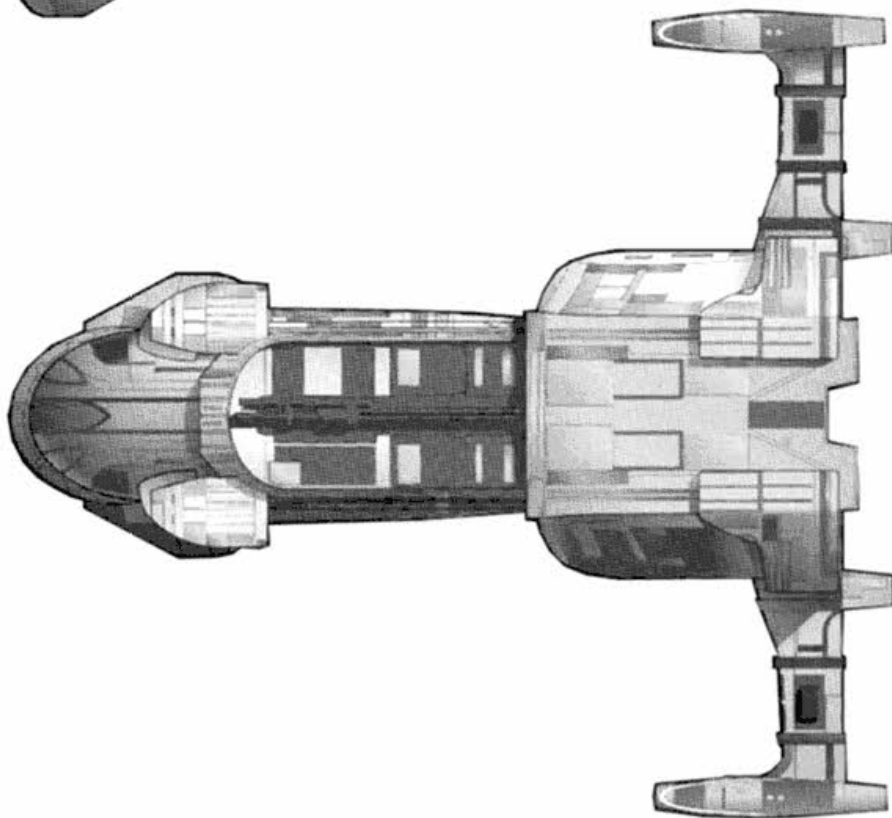
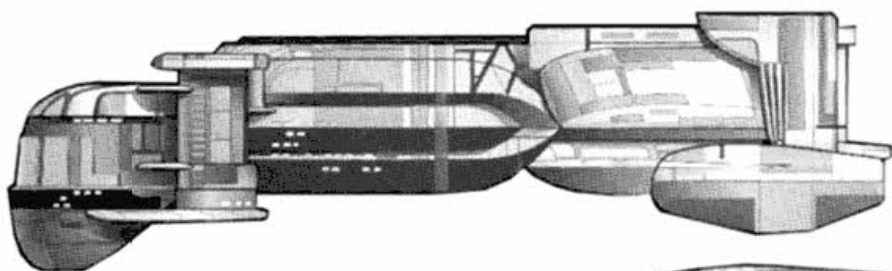



KLINGON STARSHIPS

BIRD-OF-PREY (22nd Century)



Class: Bird-of-Prey

Type: Scout

First Encountered: 2153

Production Base: Qo'noS
Orbital Factory Base

Length: 115 metres

Beam: 120 metres

Height: 48 metres

Mass: 28,000 metric tons

Crew: 18

Cruising Speed: Warp 5.1

Maximum Speed: Warp 5.8

Armament: 8 Disruptor
cannons, 2 photon torpedo
launchers

Known Ships (IKS)

Names unknown

CLASS INFORMATION:

Comparable in design to its sister classes, the *Raptor* and *D5*, the smaller *Bird-of-Prey* utilized an avian design, including feather-like hull plating on its wings.

The bridge module was located in the bulbous forward section, while the shuttlebay, impulse engines and warp nacelles were housed in the larger aft section of the ship. The *Bird-of-Prey's* arsenal was impressive for the time, with multiple disruptor mounts and forward and aft torpedo launchers. The ship's defensive systems included dispersive armour around the bridge, and deflector shields.

Earth Starfleet first encountered the *Bird-of-Prey* when Duras mounted a revenge attack on the returning *Enterprise* NX-01 on the outskirts of the Sol system in 2153.

The *Bird-of-Prey* design would be revamped and developed, resulting in the *B'rel* and *K'Vort*-class vessels of the 23rd and 24th centuries.



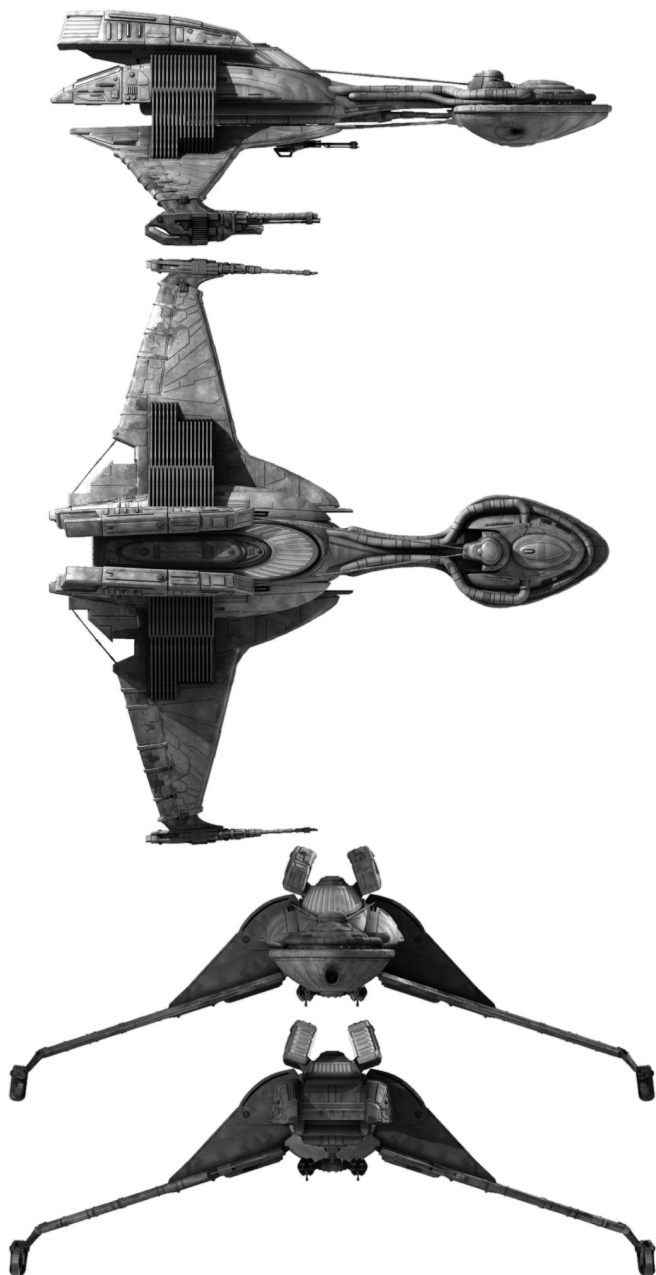

BIRD-OF-PREY (23rd Century)



Class: B'rel/K'Vort

Type: Scout/Cruiser

First Encountered: 2282/2365

Production Base: Qo'noS

Orbital Factory Base

Length: 109.7/350 metres

Beam: 162/517 metres

Height: 27/86.3 metres

Mass: 46,300/1,504,000 m. tons

Crew: 12/36

Cruising Speed: Warp 7*/6

Maximum Speed: Warp 8*/9.6

Armament: 2 Disruptor
cannons, 1 photon torpedo
launcher

* *Original Cochrane Unit (OCU)*

Known Ships (IKS)

"HMS Bounty"

B'rel

Buruk *

Ch'Tang

Etam

Hegh'ta

Hor'cha

Ki'tang

Koraga *†

Korinar

K'Vort *

M'Char

Malpara †

Ning'tao †

Orantho

Pagh *

P'Rang *

Rotarran

Slivin

Vorn *

Y'tem

* *K'Vort-class*

† *Lost or destroyed*

CLASS INFORMATION:

Developed from a 22nd century design, the *B'rel*-class fulfilled the Klingon Empire's need for a small, fast vessel that could move stealthily through hostile territories and strike quickly and effectively against a foe. The *B'rel*-class was equipped with a cloaking device and featured variable geometry wings which could be lowered into an attack position, raised for planetfall, or kept flat for cruising.

The effective design of the *B'rel*-class prompted the Klingons to develop a larger model in the second quarter of the 24th century - the *K'Vort*-class cruiser.

Notable Klingon Birds-of-Prey include General Chang's experimental prototype which attempted to disrupt the Khitomer Peace Conference, and the *I.K.S. Rotarran* - General Martok's flagship during the Dominion War.



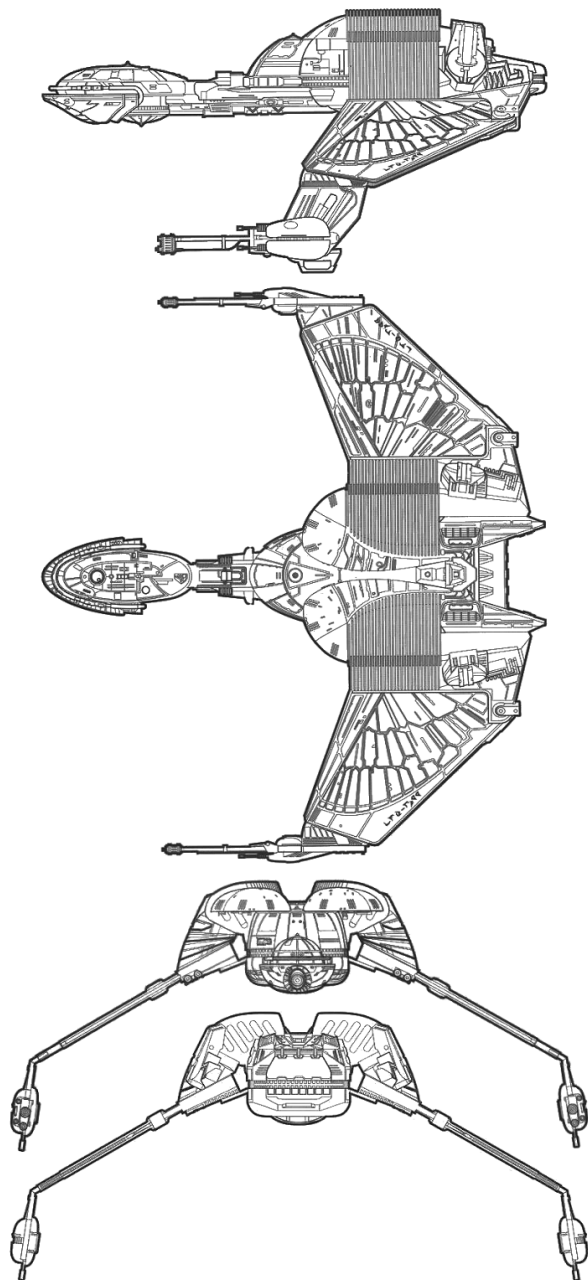

D4 CLASS



Class: D4

Type: Battlecruiser

First Encountered: 2151

Production Base: Qo'noS
Orbital Factory Base

Length: 205 metres

Beam: 136 metres

Height: 45 metres

Mass: 82,500 metric tons

Crew: 295

Cruising Speed: Warp 7

Maximum Speed: Warp 8

Armament: 4 Disruptor
cannons, 2 photon torpedo
launchers

Known Ships (IKS)

D'ama ꝑ

ꝑ *Non-canon*

CLASS INFORMATION:

The predecessor to the infamous *D7* and *K'tinga*-classes, the *D4*-class battlecruiser entered service in the 22nd century, and by the early 23rd century was the mainstay of the Klingon Imperial Fleet.

The *D4* was armed with disruptors and fore and aft photon torpedo launchers. It also featured deflector shield technology and an aft tractor beam. Like other 22nd century Klingon designs, the *D4* was fitted with additional support struts between the command and engineering hulls, as well as along the edges of the wing-structures, to augment structural integrity.

Some *D4*s served into the 2260s and Starfleet included them in Klingon tactical simulations, where they fought alongside the later *D7*-class against *Constitution*-class vessels.



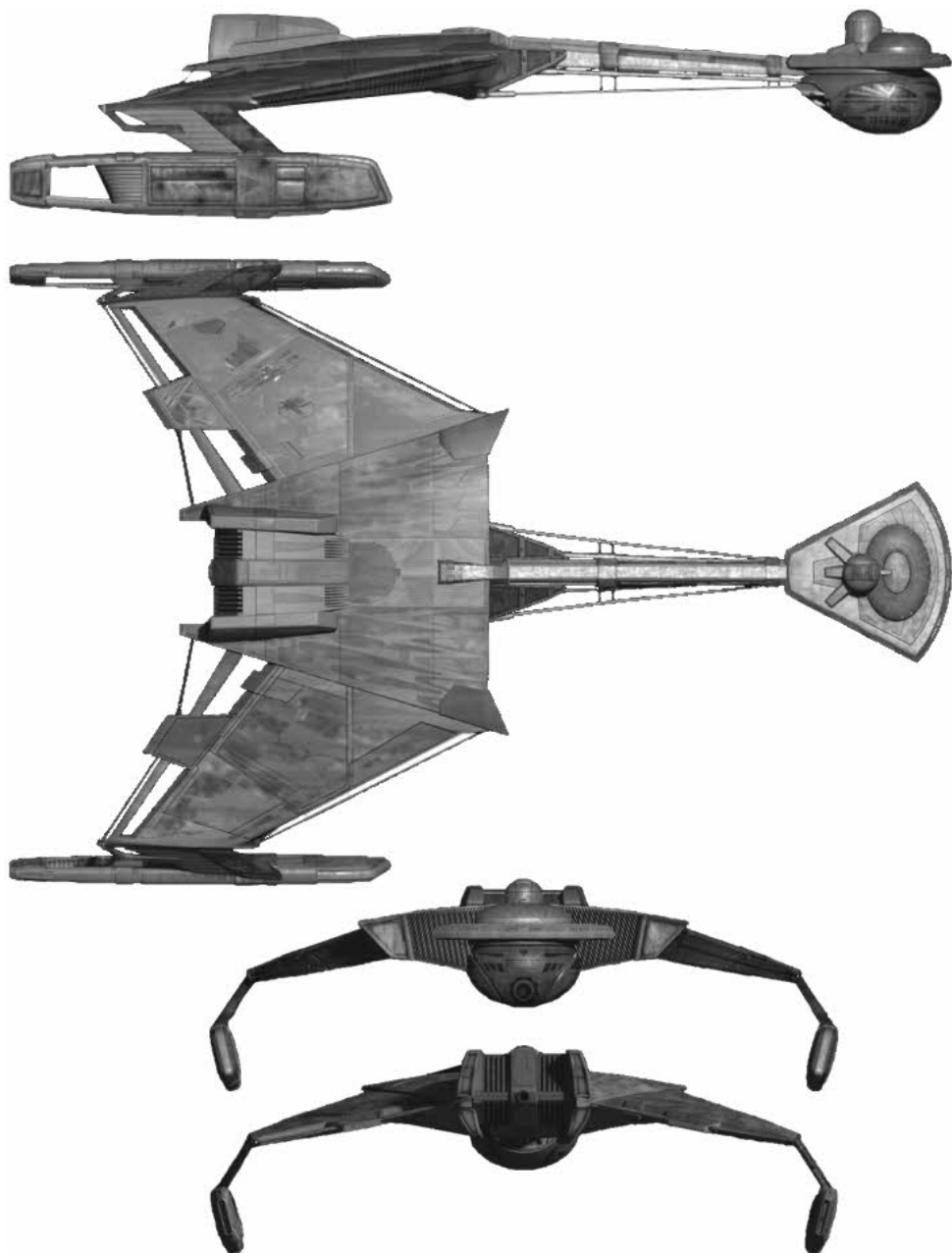

D5 CLASS



Class: D5
Type: Battlecruiser/Deuterium Tanker
First Encountered: 2152
Production Base: Qo'noS Orbital Factory Base
Length: 155 metres
Beam: 145 metres

Height: 42 metres
Mass: 183,000 metric tons
Crew: 20
Cruising Speed: Warp 5
Maximum Speed: Warp 6
Armament: 4 Disruptor cannons, 2 photon torpedo launchers

Known Ships (IKS)
Bortas
Klothos

CLASS INFORMATION:

The *D5*-class was the principal battlecruiser design of the Klingon Imperial Fleet during the mid-22nd century. Like many of its contemporaries and successors, the *D5* was distinguished by a roughly bird-like form, with an elongated primary hull and angular wings and warp nacelles.

A fully-armed *D5* was considerably more advanced than Earth Starfleet's most powerful vessel during the 2150s, the *NX*-class starship. Like its *Raptor*-class counterpart of the same era, the *D5* was outfitted with multi-spectral sensors as well as disruptors, photon torpedo launchers and dispersive armour.

Some *D5*s were modified as deuterium tankers, with eight underslung tanks. These versions carried significantly less armament than their cruiser counterparts.

Notable *D5*s included the *I.K.S. Bortas*, commanded by Duras, which was foiled in its pursuit of refugees from Rha'darus by the *Enterprise NX-01* in 2152; and the *I.K.S. Klothos*, the former command of Dahar Master Kor.



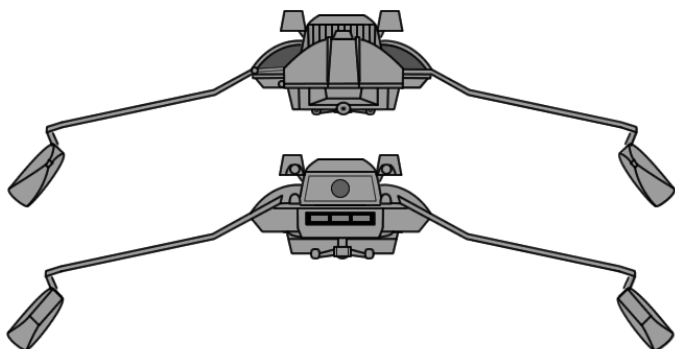
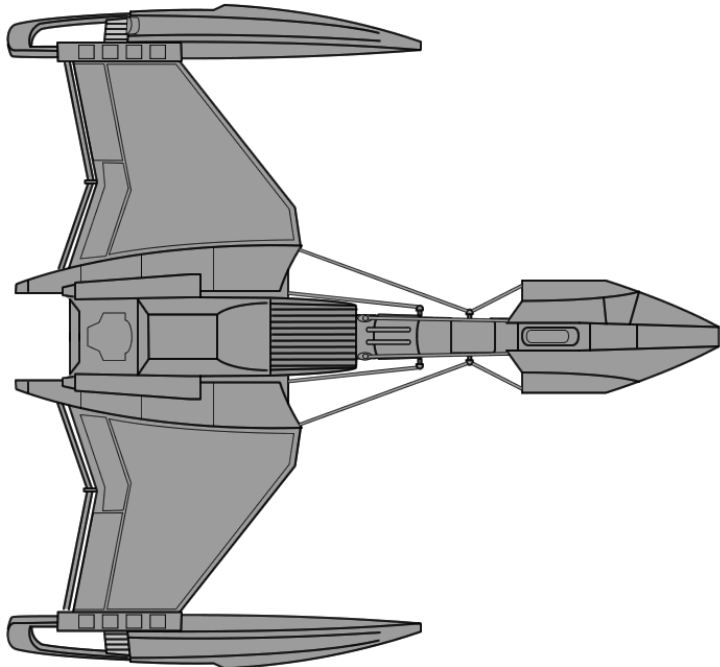
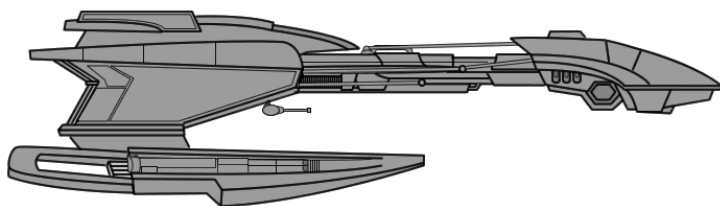

D7 CLASS

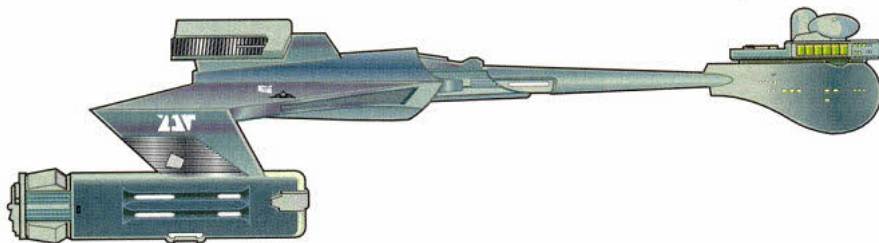

Class: D7

Type: Battlecruiser

First Encountered: 2267

Production Base: Qo'noS

Orbital Factory Base

Length: 228 metres

Beam: 169 metres

Height: 63 metres

Mass: 106,700 metric tons

Crew: 400

Cruising Speed: Warp 6 *

Maximum Speed: Warp 9 *

Armament: 2 Disruptor
cannons, 2 photon torpedo
launchers, 1 phaser emitter
* *Original Cochrane Unit (OCU)*

Known Ships (IKS)

Devisor ☿

Gr'oth

Klothos

Voh'Takh ☿

☿ *Non-canon*

CLASS INFORMATION:

The distinctive manta ray-shaped *D7*-class served as the backbone of the Klingon Defense Force during the mid-23rd century. Developed from the older *D4*-class battlecruiser, the *D7*'s range of armament made it a match for Starfleet's *Constitution*-class. The ship was not particularly manoeuvrable however, and its commanders favoured bombarding targets from long-range. In 2268 the Klingons formed an alliance with the Romulan Star Empire, resulting in a technology exchange which led to the Romulans acquiring several *D7*s and the Klingons gaining access to cloaking technology. Klingon *D7*s were first retro-fitted with cloaking devices in 2269. The success of the *D7* led to the *K't'inga*-class redesign in 2270, which became a mainstay of the Klingon fleet for over a hundred years.

Notable ships of the class include the *I.K.S. Gr'oth* commanded by Captain Koloth and the *I.K.S. Klothos* commanded by Kor which attacked the outpost at Caleb IV.

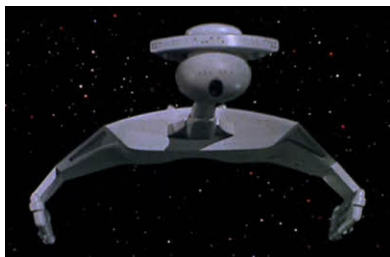

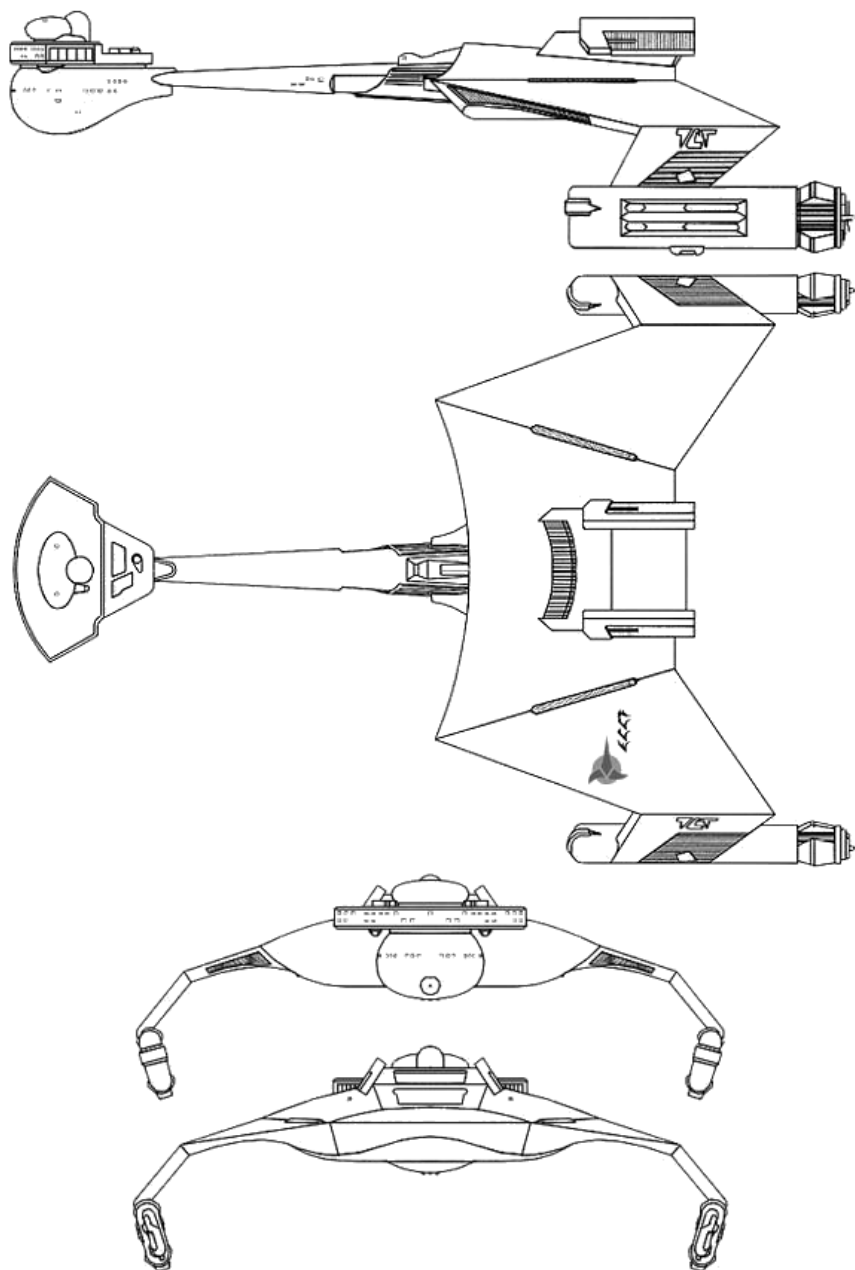

K'T'INGA CLASS



Class: K't'inga

Type: Heavy Battlecruiser

First Encountered: 2270

Production Base: Qo'noS

Orbital Factory Base

Length: 214.3 metres

Beam: 152.4 metres

Height: 57.3 metres

Mass: 120,000 metric tons

Crew: 385

Cruising Speed: Warp 6 *

Maximum Speed: Warp 10 *

Armament: 8 Disruptor
cannons, 2 photon torpedo
launchers

* *Original Cochrane Unit (OCU)*

Known Ships (IKS)

Amar †

B'Moth †

K't'inga

K'Tanco

Qo'noS Wa' (Kronos One)

T'Acog †

T'Ong

† *Lost or destroyed*

CLASS INFORMATION:

Frequent encounters with the Federation during the 2260s prompted the Klingon Empire to redesign and upgrade the *D7* battlecruiser, resulting in the *K't'inga*-class. The *K't'inga* featured a number of new innovations including a more thoroughly compartmented hull, designed to withstand multiple breaches, and improved ordinance, with enhanced disruptors replacing the *D7*'s disruptors and phaser emitter. The *K't'inga*-class was also the first Klingon vessel to be fitted with a cloaking device as standard - a result of the Klingons' brief alliance with the Romulans.

The *K't'inga*-class, though no longer in production, served with distinction into the 2370s. Famous ships of the class include the *I.K.S. Amar* which led a battle group of *K't'ingas* against the *V'Ger* probe in 2273, and the *I.K.S. Kronos One* which transported Chancellor Gorkon to peace talks with the Federation on Earth in 2293.

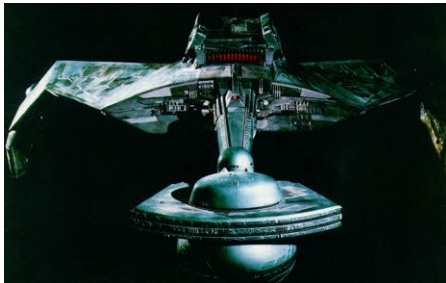

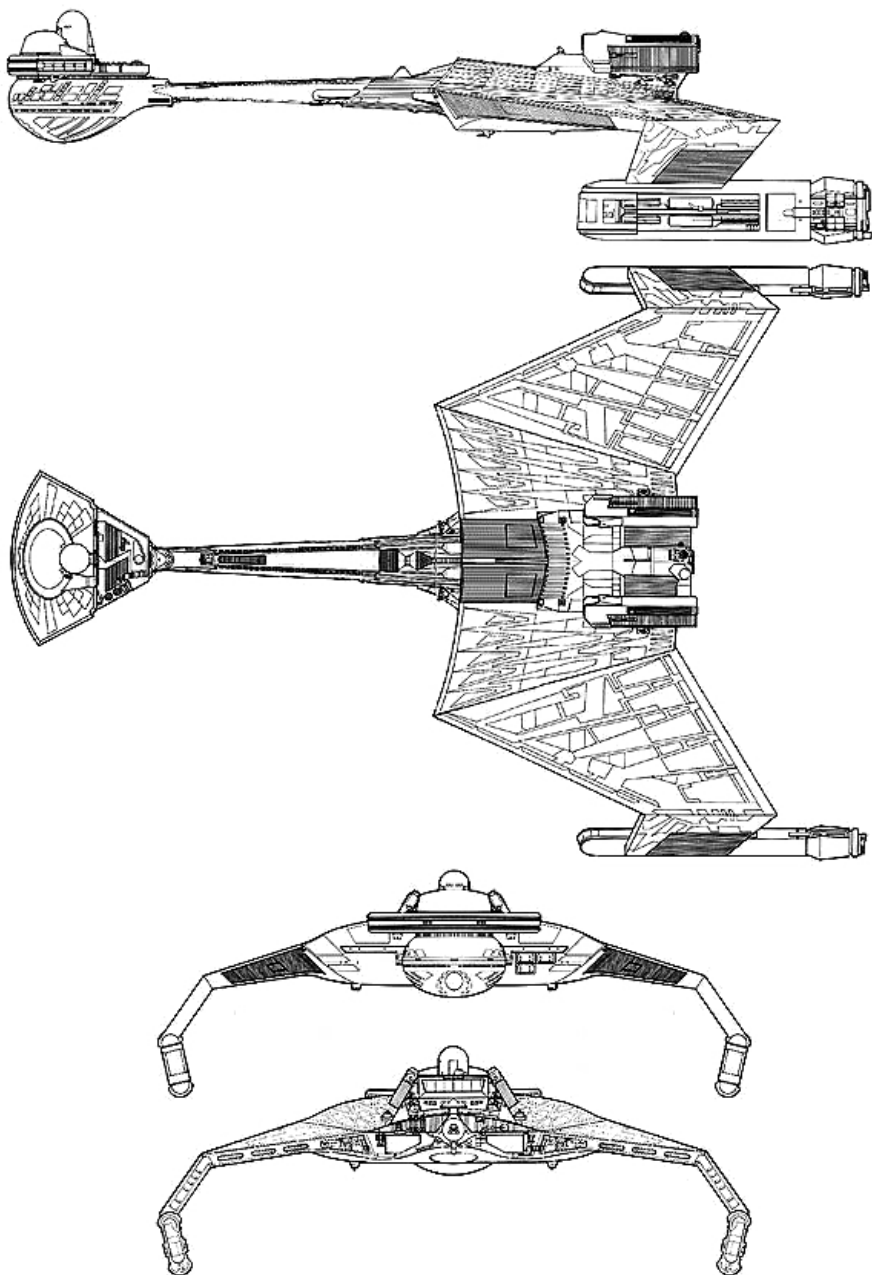

NEG'H'VAR CLASS



Class: Negh'Var

Type: Battleship

First Encountered: 2371

Production Base: Qo'noS

Orbital Factory Base

Length: 682.32 metres

Beam: 470.09 metres

Height: 136.65 metres

Mass: 4,310,000 metric tons

Crew: 2,500

Cruising Speed: Warp 6

Maximum Speed: Warp 9.6

Armament: 20 Disruptor cannons, 1 large forward disruptor, 4 photon torpedo launchers

Known Ships (IKS)

Negh'Var

Voodieh *†

* Variant

† Lost or destroyed

CLASS INFORMATION:

The largest and most powerful ship in the Klingon fleet, the *Negh'Var* represents the pinnacle of 24th century Klingon starship design. Designed to be an imposing and formidable opponent, the ship's impressive arsenal of disruptors can be fired by individual gunners or centralized through the ship's sophisticated targeting computers. The *Negh'Var* also features a large forward-mounted disruptor, and a detachable 'daughtercraft' scout ship on top of the aft hull.

The *Negh'Var*-class was developed with reliability and durability in mind. Its size dictates the use of several cloaking devices and it features multiply redundant operational systems and impulse engines.

In early 2372, the *I.K.S. Negh'Var* led the Klingon invasion of the Cardassian Union, and was Chancellor Gowron's flagship during the Dominion War.



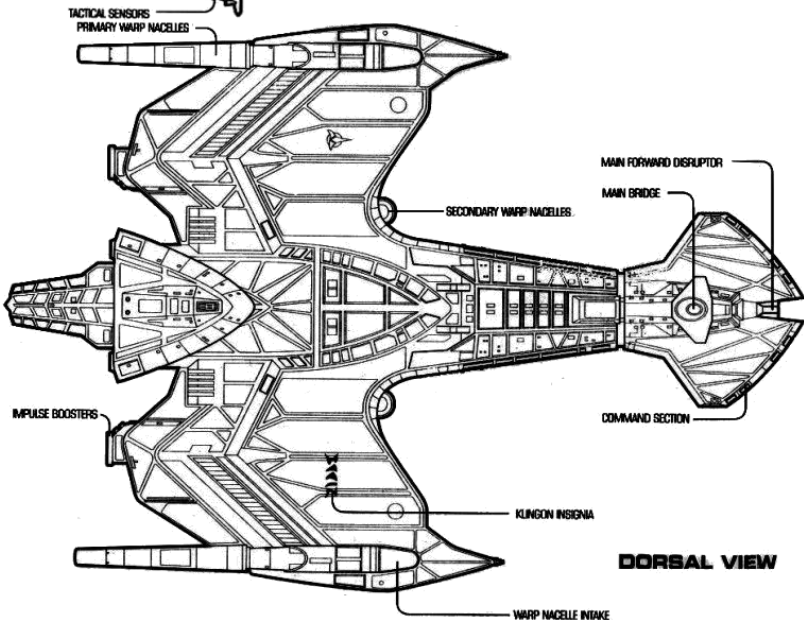
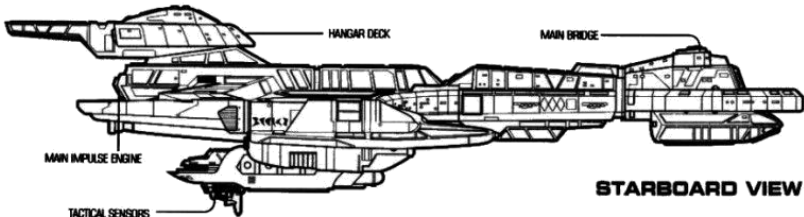
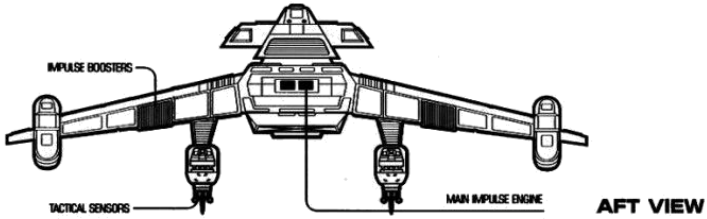
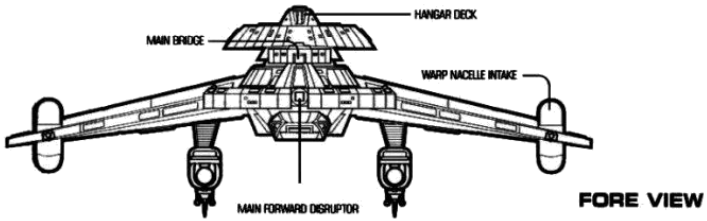

RAPTOR CLASS

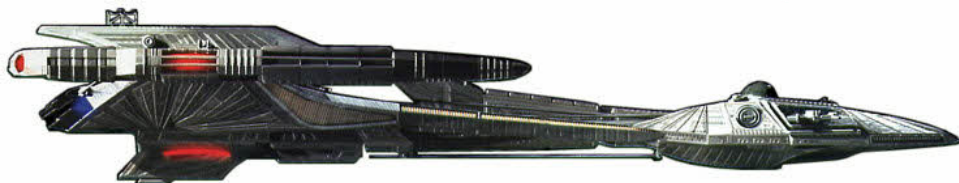

Class: Raptor

Type: Scout

First Encountered: 2151

Production Base: Qo'noS

Orbital Factory Base

Length: 145 metres

Beam: 111 metres

Height: 27 metres

Mass: 90,000 metric tons

Crew: 12

Cruising Speed: Warp 5

Maximum Speed: Warp 6

Armament: 2 Disruptor
cannons, 1 photon torpedo
launcher

Known Ships (IKS)

Somraw

CLASS INFORMATION:

The *Raptor*-class was designed for short and medium range reconnaissance missions and swift attacks. The ship was first encountered by the Vulcans prior to 2151, and the accepted *Raptor*-class name is thought to have been coined by them.

As with other Klingon vessels built prior to the Klingon-Romulan alliance of the 23rd century, the *Raptor* did not carry a cloaking device. However it did feature deflector shields and dispersive armour, despite being only relatively lightly armed. The warp nacelles were situated at the end of the *Raptor's* up-swept wings.

The first Earth encounter with a *Raptor* came in 2151, when the *Enterprise* NX-01 rescued the disabled *I.K.S. Somraw* from within the atmosphere of a gas giant. This was also the first time Starfleet personnel explored the inside of a Klingon vessel.





VOR'CHA CLASS

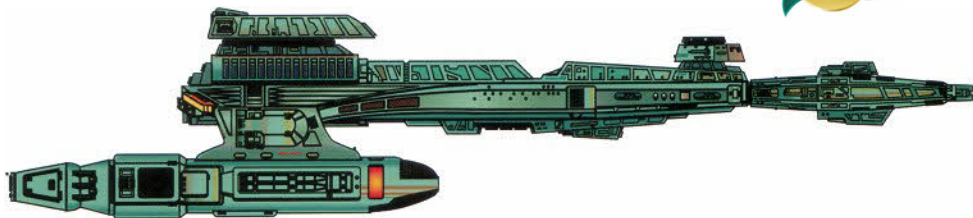

Class: Vor'cha
Type: Attack Cruiser
First Encountered: 2367
Orbital Factory Base
Length: 481.32 metres
Beam: 341.76 metres
Height: 106.87 metres

Mass: 2,238,000 metric tons
Crew: 1,900
Cruising Speed: Warp 6
Maximum Speed: Warp 9.6
Armament: 18 Disruptor cannons, 1 large forward disruptor, 3 photon torpedo launchers

Known Ships (IKS)

Bortas
Drovana
Maht-H'a
Qu'Vat
Toh'Kaht †
Vor'cha
Vor'nak
Ya'Vang
† *Lost or destroyed*

CLASS INFORMATION:

The *Vor'cha*-class succeeded the *K'tinga*-class as the primary fighting vessel of the Klingon Defense Force, and forms the backbone of the late 24th century Klingon fleet. A combat-orientated multimission vessel, the *Vor'cha*'s design echoes traditional Klingon design philosophy and lineage dating back to the *Raptor* and *D5*-classes of the 22nd century.

The *Vor'cha*-class features a detachable heavy forward disruptor cannon - one of the largest ship mounted weapons in known space - and a cloaking device. It is also the first Klingon design to incorporate Starfleet technology exchanged during the years of alliance - most notably in the Bussard collectors mounted on the nacelles, which supplement the ship's ram intakes on the wings.

Both Chancellor K'mpec and his successor Gowron used *Vor'cha*-class vessels as flagships, the *I.K.S. Bortas* serving the latter during the Klingon Civil War of 2367-68.



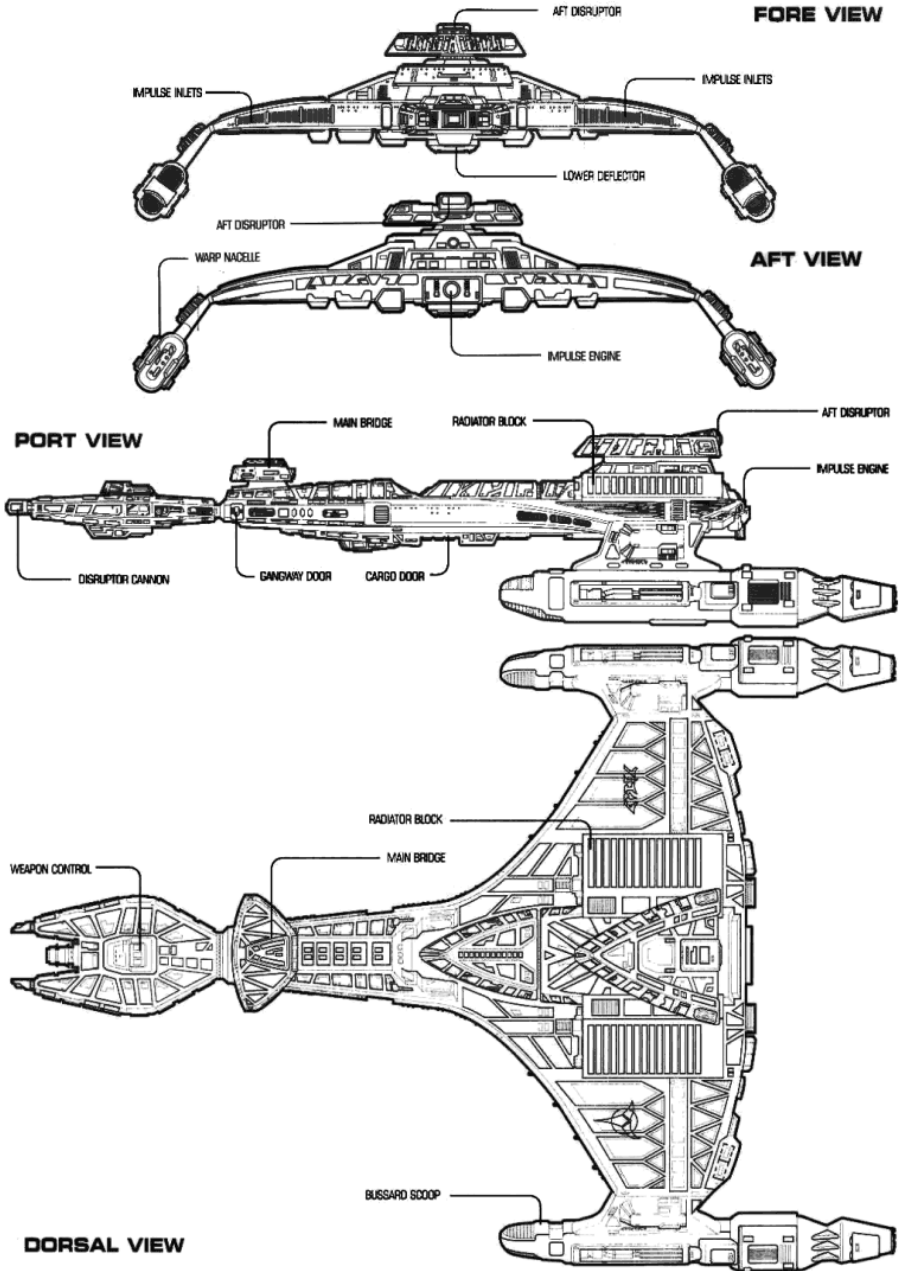



ROMULAN STARSHIPS

BIRD-OF-PREY (22nd Century)



Class: T'Liss/Bird-of-Prey

Type: Attack Ship

First Encountered: 2152

Production Base: Unknown,

Romulan Star Empire

Length: 165 metres

Beam: 182 metres

Height: 40 metres

Mass: Unknown

Crew: 100

Cruising Speed: Warp 3

Maximum Speed: Warp 5

Armament: 2 Plasma cannons,
4 photon torpedo launchers

Known Ships (IRW)

Praetor Pontilus ϕ †

T'Liss ϕ

ϕ *Non-canon*

† *Lost or destroyed*

CLASS INFORMATION:

A mainstay of the 22nd century Romulan fleet, the distinctive Romulan *Bird-of-Prey* would be developed and improved into the 2260s. The early *Bird-of-Prey*'s warp nacelles bore a strong resemblance to those of the Klingon *Raptor*, suggesting a possible technology exchange between the two powers. The ship was equipped with advanced weaponry for the time, and initially a cloaking device.

The *Enterprise NX-01* first encountered a Romulan *Bird-of-Prey* in mid-2152 when it accidentally entered a cloaked minefield. The *Praetor Pontilus* was one of two prototype cloaking ships which forced the Earth vessel to leave. Sometime afterward the *Pontilus* was destroyed in an antimatter containment failure caused by the vast power requirements of the cloak. It would subsequently be decades before the Romulans would successfully perfect a working starship cloaking device.





BIRD-OF-PREY (23rd Century)

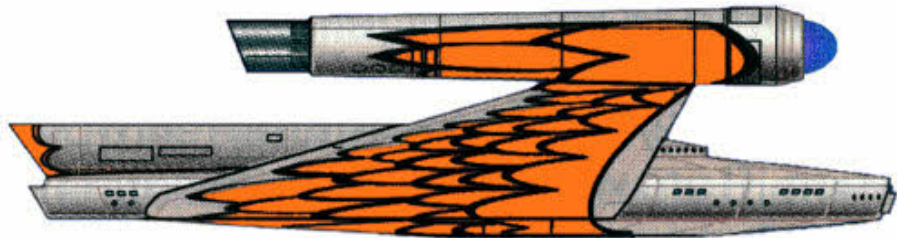

Class: Vas'Hatham/Bird-of-Prey

Type: Cruiser

First Encountered: 2266

Production Base: Unknown,
Romulan Star Empire

Length: 68.2 metres

Beam: 90.6 metres

Height: 21.9 metres

Mass: 25,000 metric tons

Crew: 170

Cruising Speed: Warp 6 *

Maximum Speed: Warp 8 *

Armament: 1 Plasma torpedo
launcher, 10 nuclear fusion
missile tubes

* *Original Cochrane Unit (OCU)*

Known Ships (IRW)

Gal Gath'thong ††

Vas'Hatham †

Vek'lar ††

† *Non-canon*

† *Lost or destroyed*

CLASS INFORMATION:

Gaining its name from the large predatory bird painted on the ship's ventral hull, the *Romulan Bird-of-Prey* was the successor to a similar 22nd century counterpart.

The small, compact design featured few comforts, but was notable for two key systems: a cloaking device and a powerful focused plasma energy weapon which took up a large part of the ship's interior. Both had drawbacks however: the ship's plasma bolts were limited in range, and while devastating at close quarters, weakened in intensity the more distance they covered; while the ship's cloak used massive amounts of power, and the *Bird-of-Prey* was unable to fire, raise shields or use transporters while it was activated.

The *U.S.S. Enterprise NCC-1701* pursued a *Bird-of-Prey* which crossed the Neutral Zone and destroyed several outposts in 2266, and *Birds-of-Prey* were subsequently used in large numbers to patrol the border with the Federation. The last of the class was removed from service early in the 24th century.



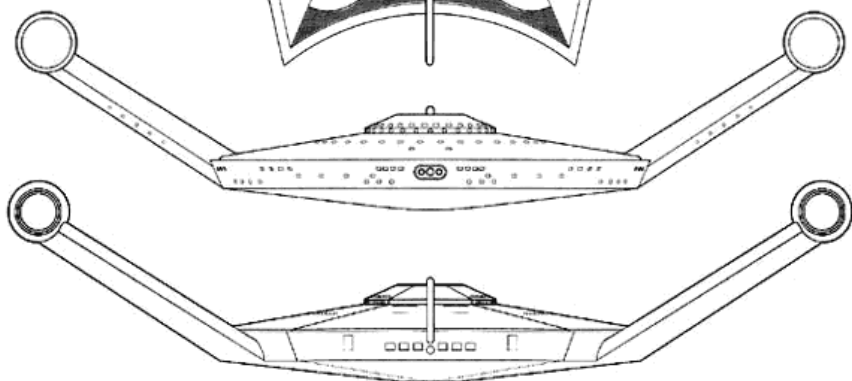
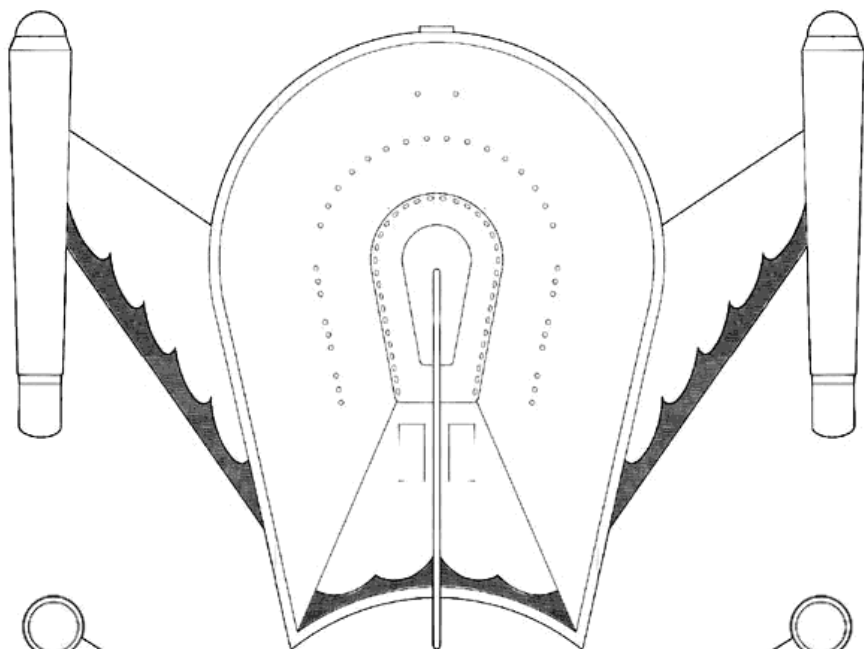
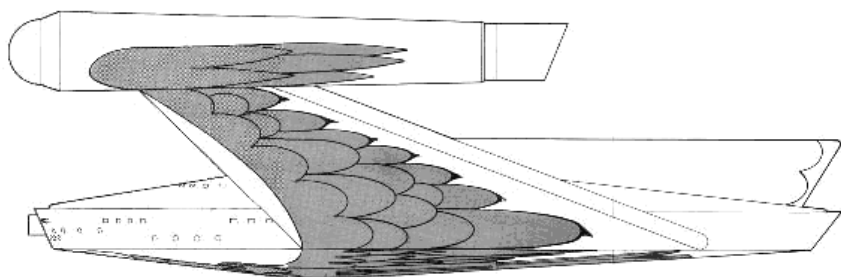

D'DERIDEX CLASS

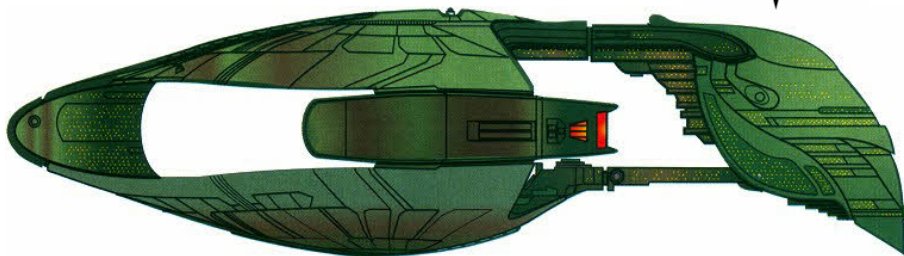

Class: D'deridex

Type: Warbird

First Encountered: 2349

Production Base: Unknown,
Romulan Star Empire

Length: 1,041.65 metres

Beam: 772.43 metres

Height: 285.47 metres

Mass: 4,320,000 metric tons

Crew: 1,500

Cruising Speed: Warp 5

Maximum Speed: Warp 9.6

Armament: 6 Disruptor arrays,
2 photon torpedo launchers

Known Ships (IRW)

Belak †

D'deridex

Decius

Devoras

Dividices

D'ridthau †

Genorex

Haakona

Khazara

Koderex *

Makar †

T'Met

Terix

Tomal *

* PWB † Lost or destroyed

CLASS INFORMATION:

One of the largest vessels in known space, the *D'deridex*-class or *B-Type* warbird fulfils a multimission role but is most effective in combat and containment.

The *D'deridex*, in common with other Romulan vessels of the 24th century, is powered by an artificial quantum singularity, and equipped with an advanced cloaking device. The ship's bilateral navigation and sensor arrays can reduce the chance of detection while cloaked.

Starfleet first encountered the *D'deridex*-class in 2364, during the first contact between the Romulans and the Federation since the Tomed Incident in 2311. The class served with distinction in the Dominion War, helping to turn the tide against the Dominion. Notable vessels of the class include the *I.R.W. D'ridthau* - the flagship of the Romulan fleet - which fell at the Battle of Cardassia in 2375.

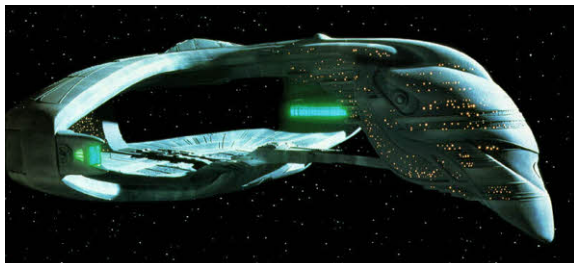

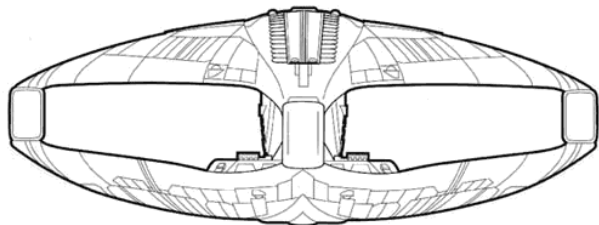
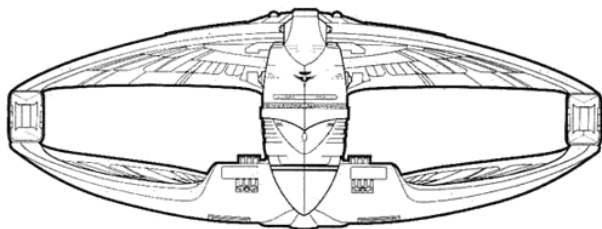
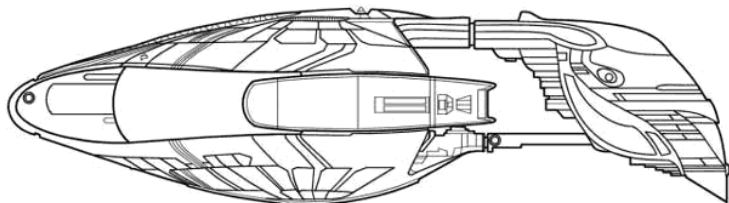
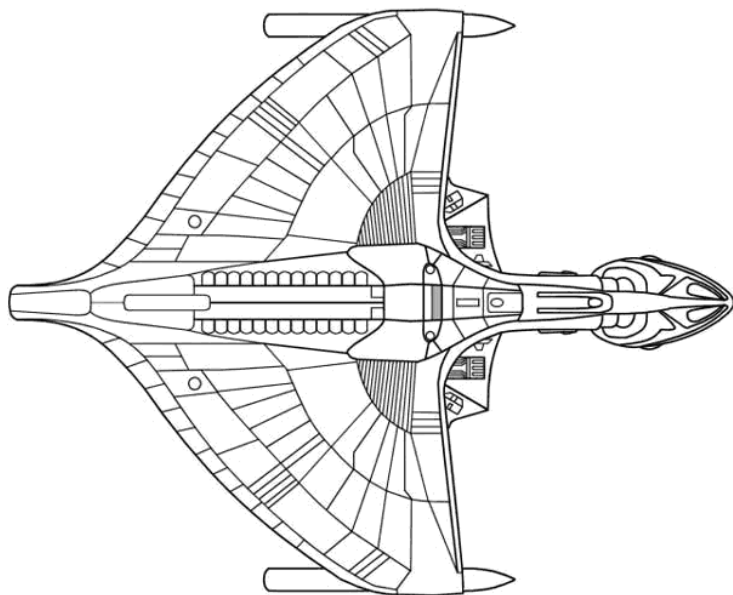

DRONE SHIP

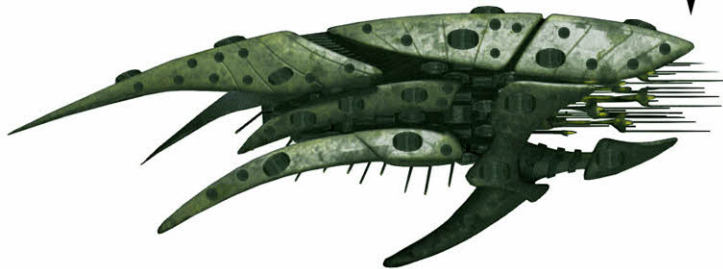

Class: Drone
Type: Modified Warbird
First Encountered: 2154
Production Base: Unknown, Romulan Empire
Length: 35 metres
Beam: 14.3 metres
Height: 9.4 metres

Mass: Unknown
Crew: 0
Cruising Speed: Warp 3
Maximum Speed: Warp 5
Armament: Tri-phasic emitters

Known Ships (IRW)
Raptor †
† *Lost or destroyed*

CLASS INFORMATION:

The Romulan drone ship was an advanced experimental attack ship developed in the 2150s. The starship itself was a modified Romulan Warbird designed to be remotely controlled from Romulus by an Aenar pilot using a telepresence unit.

The drone ship was equipped with a multi-spatial emitter system, which allowed it to assume the appearance of nearly any other vessel. Additionally, the drone's tri-phasic disruptors could mimic the weapon signatures of other ships. Its ability to self-repair also proved an asset during battle, where damage could begin to be corrected almost immediately. The drone was also highly manoeuvrable as with no crew, life-support and inertial damping power could be diverted to the engines.

Two prototype drones were launched in 2154 to try destabilise political alliances in the region, but were destroyed when their Aenar pilot turned them on one another.



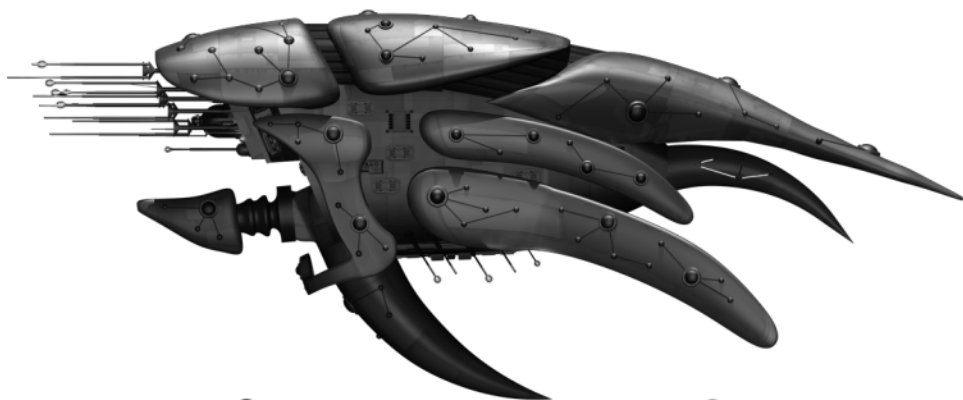
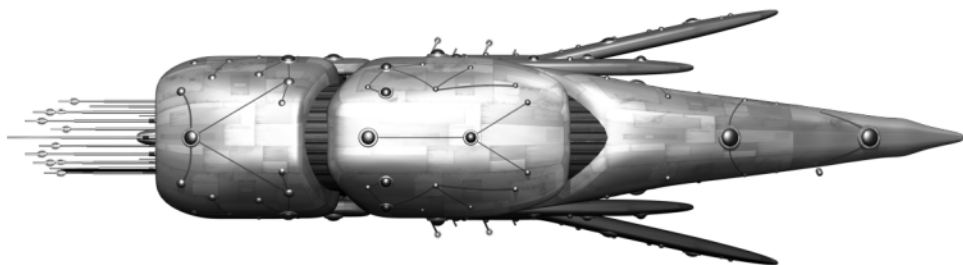

KESTREL CLASS

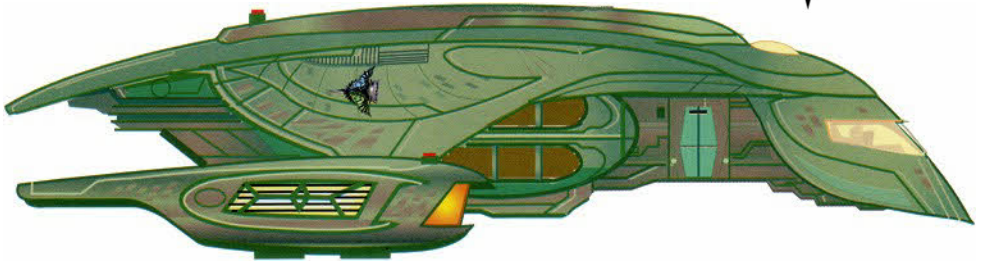

Class: Kestrel

Type: Courier

First Encountered: 2374

Production Base: Unknown,
Romulan Star Empire

Length: 24.23 metres

Beam: 15.98 metres

Height: 6.57 metres

Mass: 142.31 metric tons

Crew: 15

Cruising Speed: Warp 5

Maximum Speed: Warp 9.6

Armament: 6 Disruptor
cannons, 2 photon microtorpedo
launchers

Known Ships (IRW)

D'era ϕ †

Kestrel ϕ

Theta ϕ

ϕ *Non-canon*

† *Lost or destroyed*

CLASS INFORMATION:

The *Kestrel*-class warp-shuttle (to use its Starfleet designation) is comparable in size to a Federation runabout, and fulfils a similar role. The ship performs as a fast courier, delivering sensitive materials or information between fleets and outposts of the Romulan Star Navy. It also provides support for rapid response scientific exploration, orbital and planetary research, and reconnaissance. *Kestrel*-class vessels are also often used as shuttles on *D'deridex*-class warbirds. Like all known Romulan ships, the *Kestrel* possesses a cloaking device.

Romulan Senator Vreenak traveled to a secret meeting with Benjamin Sisko on *Deep Space 9* aboard such a shuttle in 2374, before his ship exploded returning to Romulus. The Tal Shiar concluded that the senator had been assassinated by Dominion agents - precipitating the Romulan Empire's entry into the Dominion War.



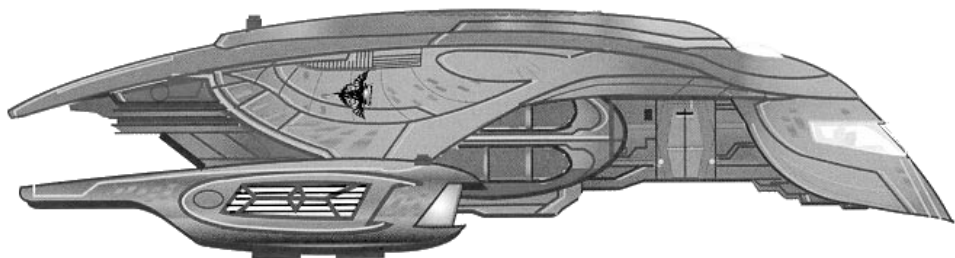
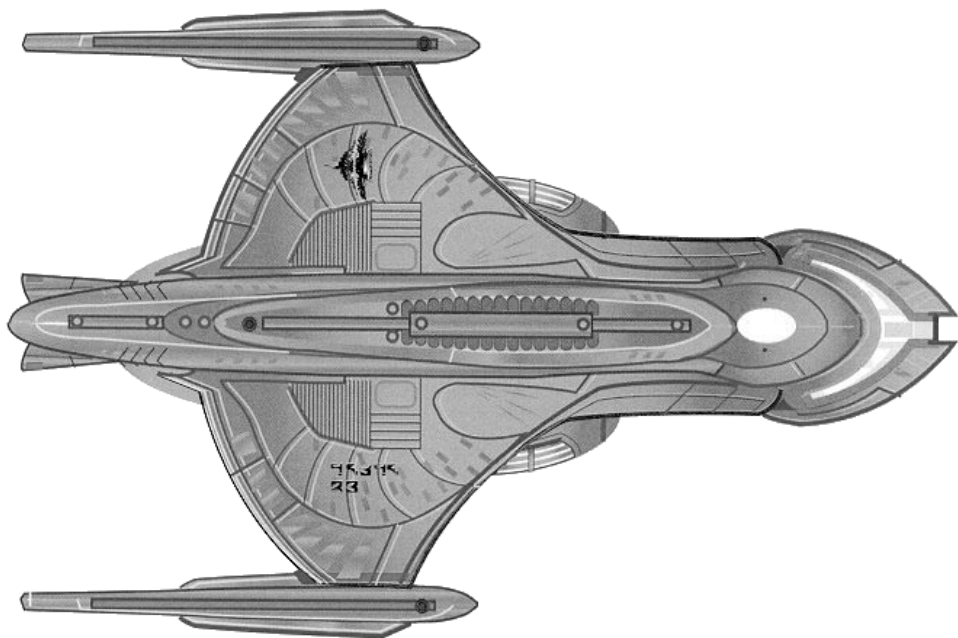

MOGAI CLASS



Class: Mogai
Type: Warbird
First Encountered: 2378
Production Base: Unknown, Romulan Star Empire
Length: 603.5 metres
Beam: 908.3 metres
Height: 94 metres

Mass: 4,800,000 metric tons
Crew: 395
Cruising Speed: Warp 6
Maximum Speed: Warp 9.95
Armament: 12 Disruptor cannons, 6 photon torpedo launchers

Known Ships (IRW)
Mogai ϕ
Norexan ϕ
Soterus ϕ †
Valdore
 ϕ *Non-canon*
† *Lost or destroyed*

CLASS INFORMATION:

The *Mogai*-class warbird was one of the most advanced vessels in the Romulan Fleet during the late 2370s.

Apparently incorporating design elements of the *D'deridex*-class warbird and Klingon *K'Vort*-class cruiser, the *Mogai*-class is a large, highly-maneuvrable, fixed-wing battlecruiser. In common with other Romulan vessels the hull is marked by distinctive feather-shaped plating. The *Mogai*-class carries several advanced disruptor cannons on each wing and in the forward section of the ship. The *Mogai* also features a sensor array superior to that of the Federation *Sovereign*-class starship, and a cloaking device.

Notable ships of the class include the *I.R.W. Valdore*, one of two *Mogai*-class warbirds which assisted the *USS Enterprise* NCC-1701-E in confronting Praetor Shinzon's rogue Reman warbird, the *Scimitar*, in the Bassen Rift in 2379.



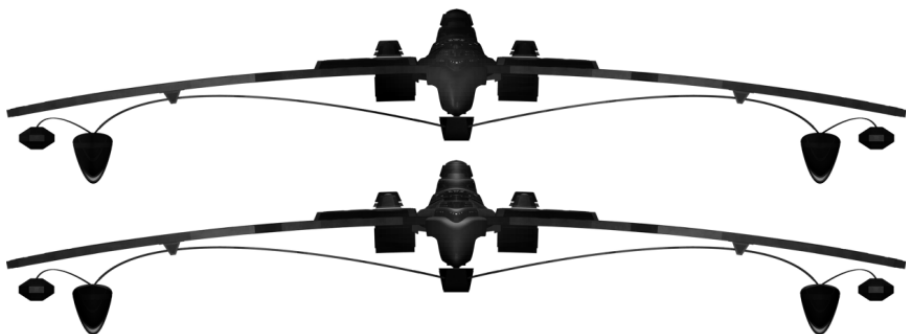

NEH'VOR CLASS

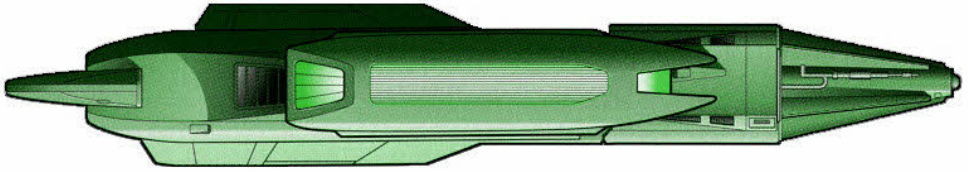

Class: Neh'vor
Type: Science Vessel
First Encountered: 2368
Production Base: Unknown, Romulan Star Empire
Length: 95 metres
Beam: 73 metres
Height: 17 metres

Mass: 57,000 metric tons
Crew: 82
Cruising Speed: Warp 6
Maximum Speed: Warp 8.6
Armament: 2 Disruptor cannons, 1 photon torpedo launcher

Known Ships (IRW)

Apnex ϕ
Henndal ϕ
Neh'vor ϕ
Talvath
 ϕ *Non-canon*

CLASS INFORMATION:

The *Neh'vor*-class science vessel was developed alongside the *Terethi*-class scout, using the same schematics for most structures and systems. Aside from the basic aesthetic differences, the *Neh'vor* differs in having improved sensors, more quarters for its much larger crew and far superior science systems.

The Romulan Star Navy uses *Neh'vor*-class vessels to test new weaponry and systems, in addition to its basic exploratory and scientific missions. During times of conflict, *Neh'vors* are also often pressed into service as scouts.

In 2368 a *Neh'vor*-class vessel suffered a forced chamber explosion in its resonator coil due to interaction with an experimental interphasic cloaking device it was testing. The ship was assisted and repaired by the *USS Enterprise* NCC-1701-D. The Romulans subsequently discontinued development of the phasing cloak.



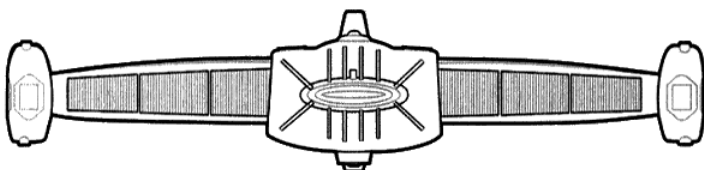
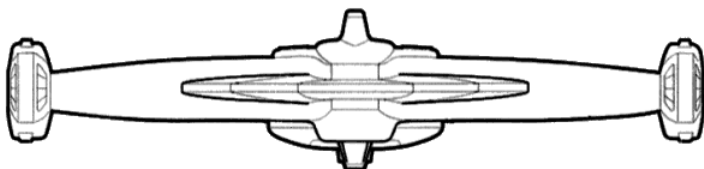
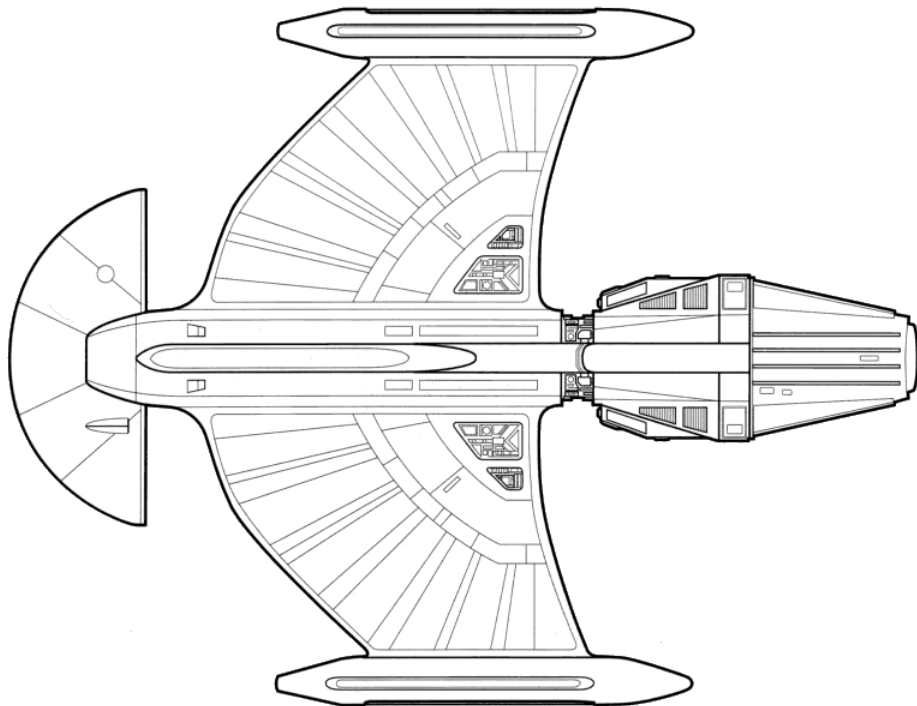
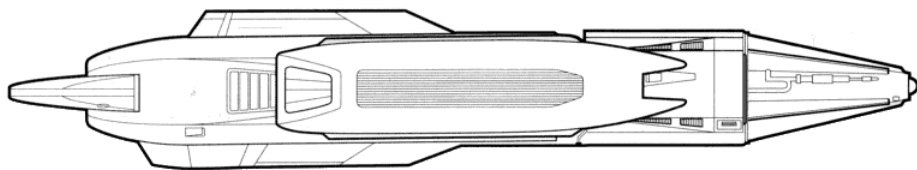

TERETHI CLASS

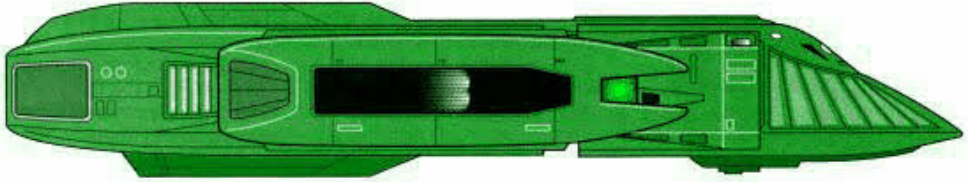

Class: Terethi

Type: Scout

First Encountered: 2366

Production Base: Unknown,
Romulan Star Empire

Length: 89 metres

Beam: 72 metres

Height: 16.5 metres

Mass: 5,830 metric tons

Crew: 2

Cruising Speed: Warp 6

Maximum Speed: Warp 8.6

Armament: 2 Disruptor
cannons, 1 photon torpedo
launcher

Known Ships (IRW)

Gethald †

Lanora †

Pi †

Terethi †

Theta †

† *Non-canon*

† *Lost or destroyed*

CLASS INFORMATION:

The *Terethi*-class scout (known by a number of different names to Starfleet Intelligence) is intended for long-range scientific exploration and military reconnaissance missions. Fast and manoeuvrable, the *Terethi*-class can also be used as a courier, as well as being effective in some battle situations, as was demonstrated on several occasions during the Dominion War.

In 2366, the Romulan scout ship *Pi* crash-landed on Galorndon Core while on a covert mission inside Federation space. The *Pi* was destroyed with an ultritrium explosive after the crash to prevent its capture by Starfleet. A few weeks later Romulan Admiral Jarok used a scout ship to cross the Neutral Zone and defect to the Federation. Jarok also destroyed his vessel to prevent its capture.



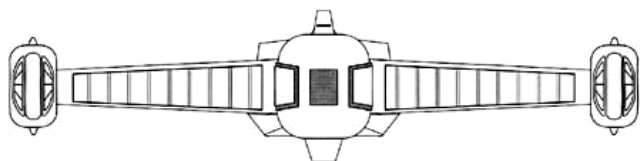
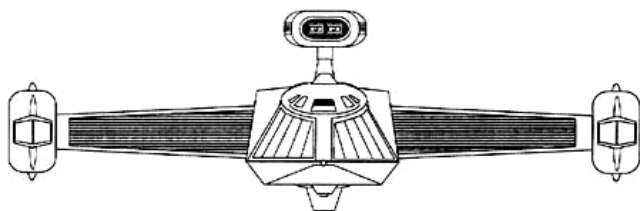
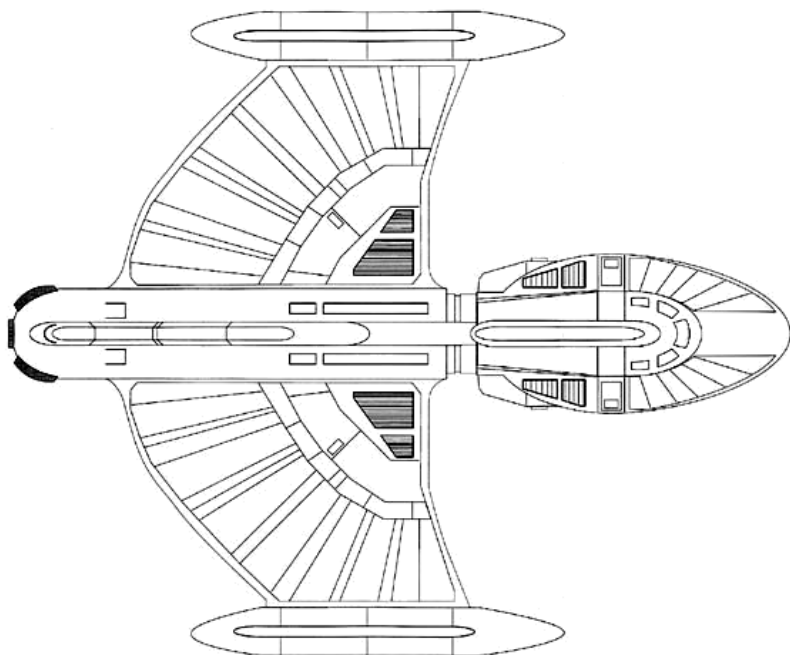
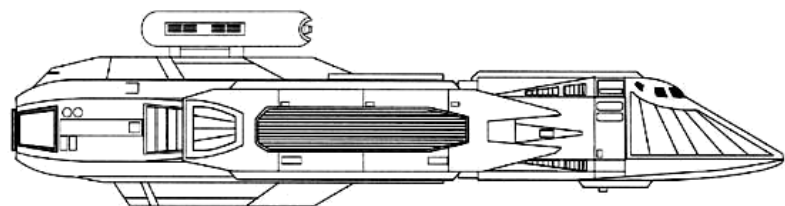



CARDASSIAN STARSHIPS

GALOR CLASS



Class: Galor

Type: Cruiser/Destroyer

First Encountered: 2355

Production Base: Cardassia
Prime Orbital 3 Assembly Facility

Length: 371.88 metres

Beam: 192.33 metres

Height: 59 metres

Mass: 1,678,000 metric tons

Crew: 300

Cruising Speed: Warp 5

Maximum Speed: Warp 9.6

Armament: 8 Spiral-wave
disruptor mounts, 1 large aft
disruptor wave cannon

Known Ships

Aldara

Galor

Kraxon

Prakesh †

Reklar

Trager

Vetar

† *Lost or destroyed*

CLASS INFORMATION:

Named for a mythological hooded warrior, the *Galor*-class is the Cardassian Union's primary combat and defence vessel. The *Galor* has been used for interdiction, border patrol, troop transport, escort, orbital assault and blockade duties. The ship's lack of extensive sensors and laboratories limits its scientific capabilities however. The *Galor*-class had impressive combat capability when first encountered during the Federation-Cardassian Wars of the 2350s, but now lags behind vessels such as the Klingon *Vor'cha* and Federation *Nebula*-classes. To compensate for this *Galor*-class ships routinely patrol in groups of three.

As with some other Cardassian designs, the *Galor's* warp engines are embedded in the wings, and the spaceframe is simpler and more robust than Starfleet equivalents, needing a less powerful structural integrity field. Armament varies from ship to ship, but includes distinctive large forward and aft spiral-wave disruptor mounts, with smaller disruptors or phasers providing coverage around the ship.

Galor-class vessels featured heavily in the Cardassian Wars and the Dominion War.



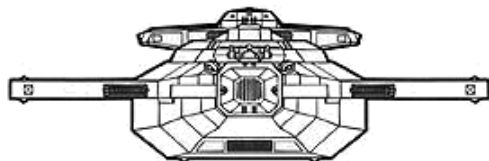
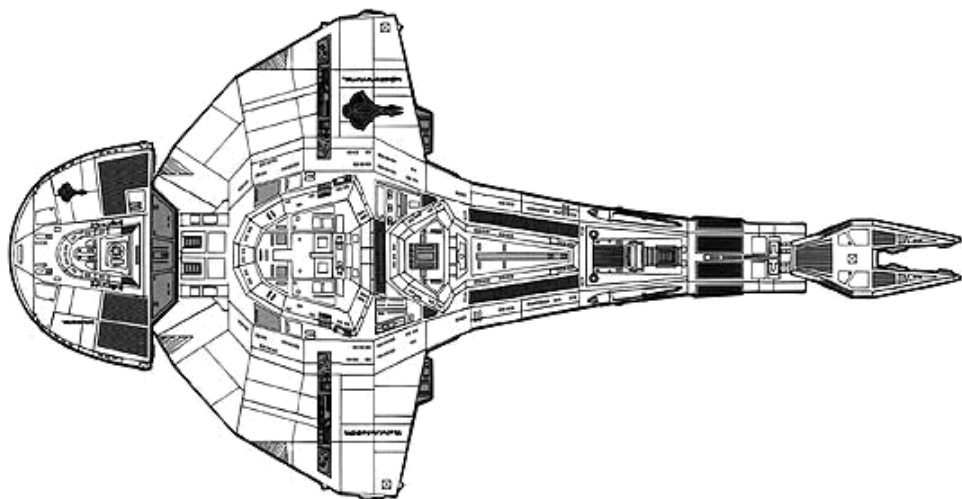
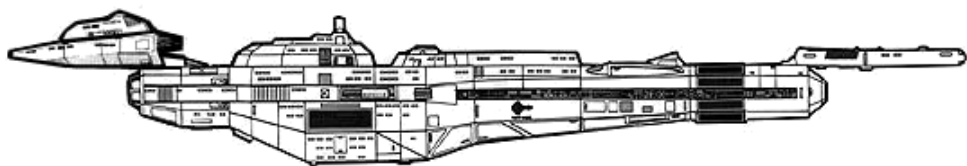

GROUMALL CLASS

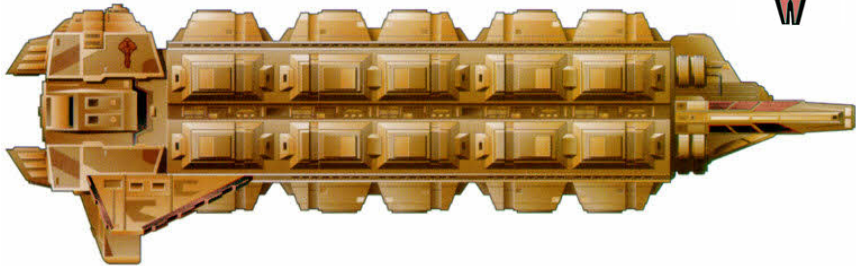

Class: Groumall

Type: Military Freighter

First Encountered: 2372

Production Base: Cardassia
Prime Orbital 3 Assembly Facility

Length: 255.65 metres

Beam: 55.13 metres

Height: 63.21 metres

Mass: 1,340,000 metric tons

Crew: 30

Cruising Speed: Warp 5

Maximum Speed: Warp 6.5

Armament: 4 Spiral-wave
disruptor mounts, 1 medium aft
disruptor wave cannon

Known Ships

Groumall †

Rabol

Ravinok †

Salgar ☿

☿ *Non-canon*

† *Lost or destroyed*

CLASS INFORMATION:

The standard cargo carrier of the Cardassian military, the *Groumall*-class military freighter was designed to transport resources from their planets of origin, such as Bajor, to Cardassia Prime and other installations inside the Cardassian Union.

The modular nature of the *Groumall's* cargo holds allow for a high degree of customisation. Over 90% of the freighter's volume is cargo space, and the ship is capable of holding up to 4,000 cubic metres of supplies.

Military freighters were often used to transport civilians and ground forces. The Obsidian Order was also known to use military freighters as decoys, or to transport operatives throughout the region around Cardassian space.

The *Groumall* itself was destroyed by its own crew, who used transporters to switch places with that of an attacking Klingon *Bird-of-Prey* at Loyal in 2372.



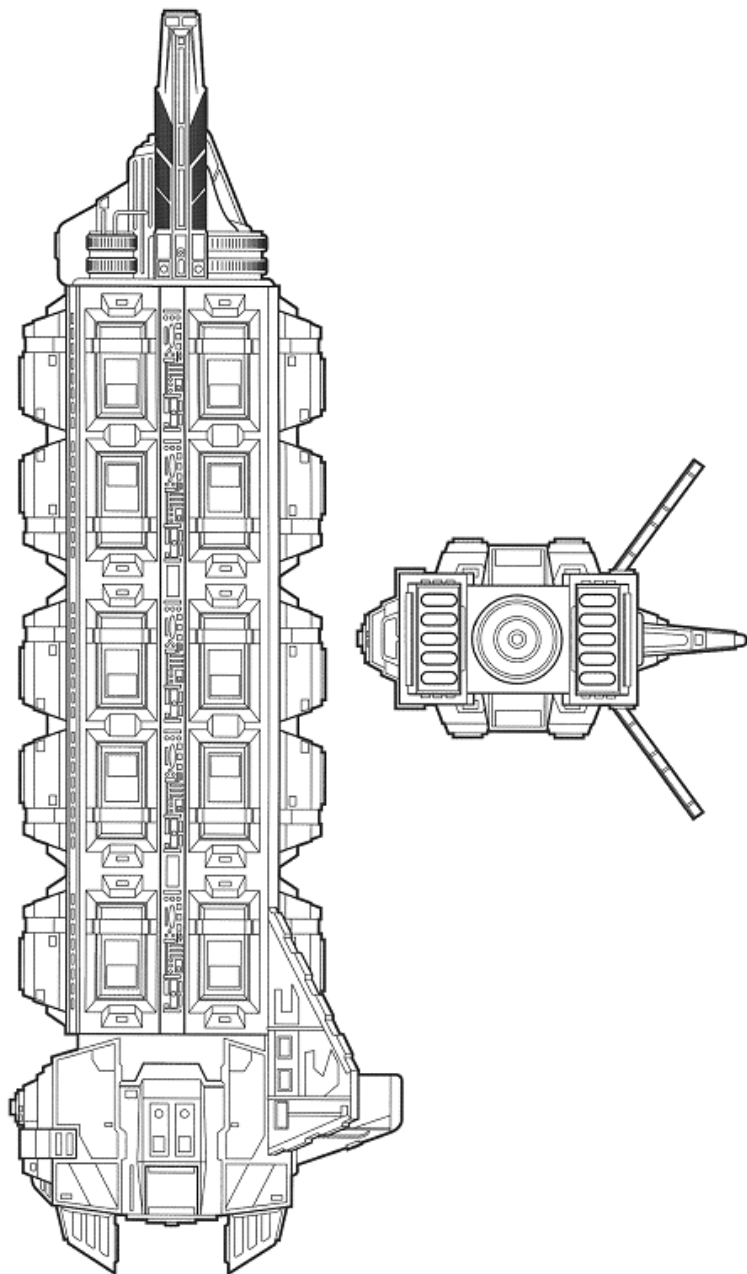

HIDEKI CLASS

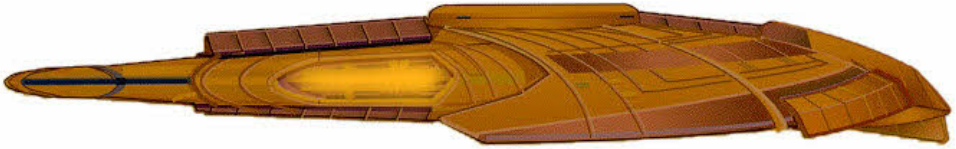

Class: Hideki
Type: Fighter/Patrol Ship
First Encountered: 2370
Production Base:
Length: 85.78 metres
Beam: 60.14 metres
Height: 12.43 metres
Mass: 120,000 metric tons

Crew: 30
Cruising Speed: Warp 5
Maximum Speed: Warp 9.5
Armament: 4 Spiral-wave disruptor mounts, 1 medium aft disruptor wave cannon

Known Ships
Hideki

CLASS INFORMATION:

Small, sleek, fast and heavily armed, the *Hideki*-class vessel is the primary fighter used by the Cardassian Central Command. Virtually every Cardassian fleet includes at least a few squadrons of *Hidekis*. Fleets permanently stationed in a particular region usually allow their fighters to operate on their own within a limited range. The *Hideki* is also used for border patrol or system defence duties, freeing up the larger ships for offensive duties.

Starfleet believe some design elements of the Federation's *Defiant*-class escort may have been incorporated into the *Hideki*, most notably a detachable warhead contained in the forward notch of the command hull. The warhead has the same yield as two Federation Type II Photon Torpedoes.



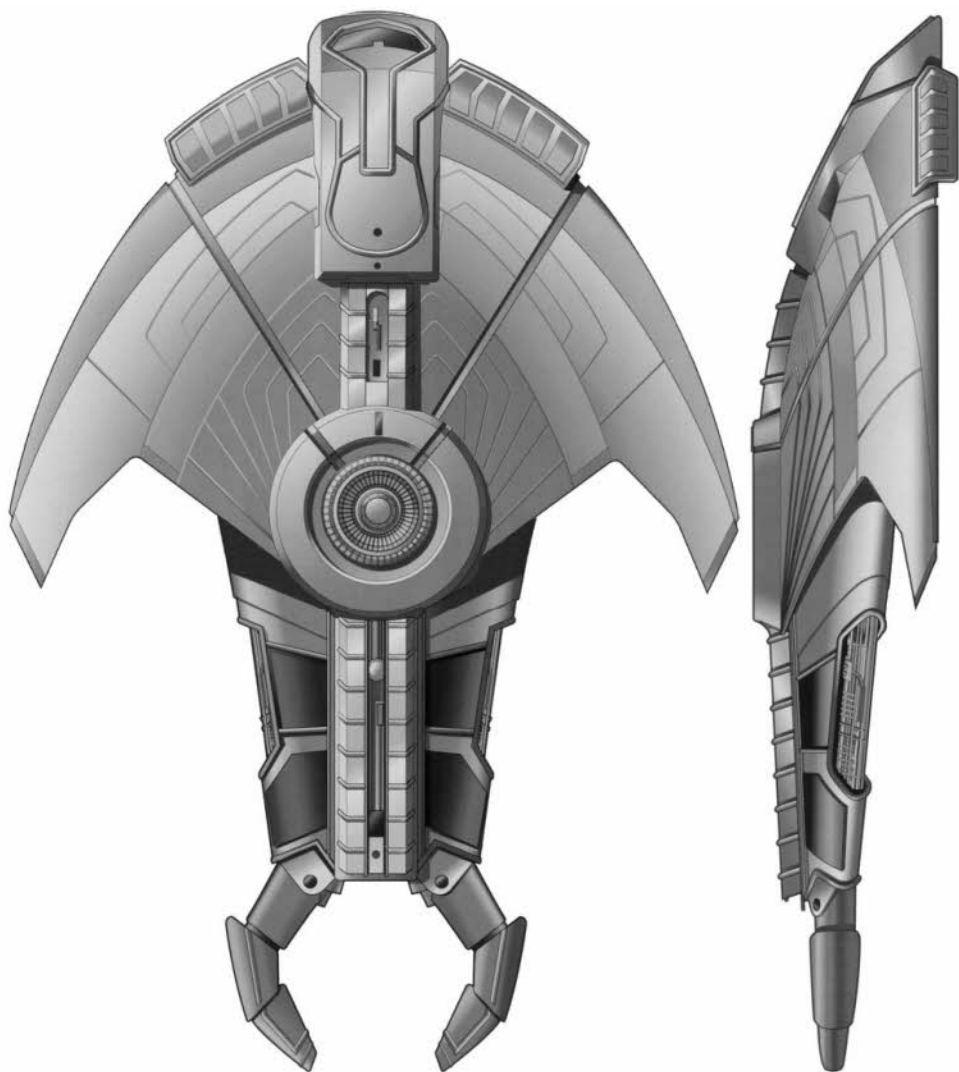

KELDON CLASS



Class: Keldon
Type: Heavy Cruiser
First Encountered: 2371
Production Base: Cardassia Prime
Orbital 3 Assembly Facility
Length: 371.88 metres
Beam: 192.23 metres
Height: 70.13 metres

Mass: 2,230,000 metric tons
Crew: 500
Cruising Speed: Warp 6
Maximum Speed: Warp 9.6
Armament: 8 Spiral-wave disruptor mounts, 1 large aft disruptor wave cannon

Known Ships
Keldon
Koranak *†
† *Lost or destroyed*
* *Obsidian Order variant*

CLASS INFORMATION:

Based on the *Galor*-class destroyer design, the larger *Keldon*-class cruiser is the most powerful vessel in the Cardassian fleet. The *Keldon* was conceived to address deficiencies in the *Galor*'s design and maintain military parity with Starfleet and the Klingon Defence Force. The hull is extended compared to the *Galor*-class with a large troop or cargo module on the top and two 'tail fins' towards the stern. The spaceframe is designed to withstand greater stresses, and sensor and computer systems have been improved. Building the *Keldon* was more cost and resource-intensive however, and fewer have been constructed.

A number of *Keldon*-class warships were secretly commissioned by the Obsidian Order in the Orias system in 2371. Built in cooperation with the Romulan Tal Shiar, the upgraded *Keldons* were fitted with cloaking devices and had enhanced top speeds and weaponry. These ships were used in the abortive attack on the Founders' homeworld later that year, before being destroyed in a Dominion ambush.



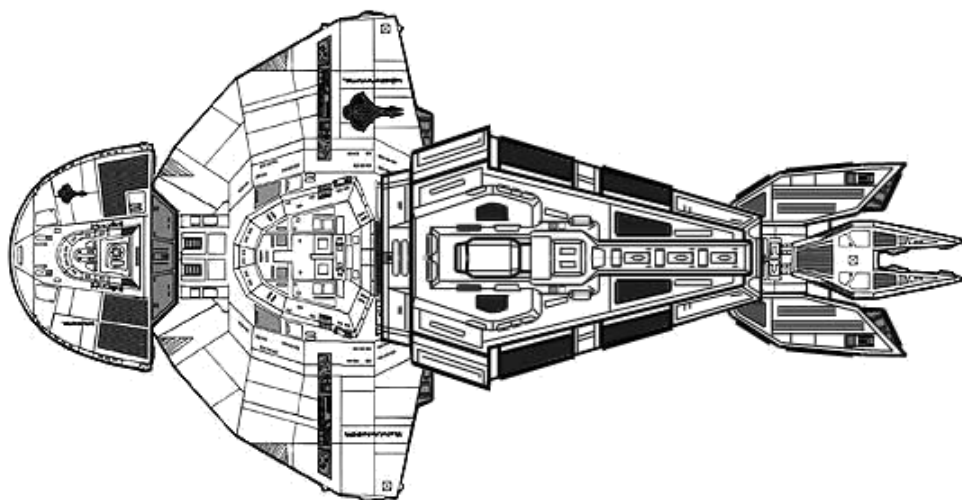
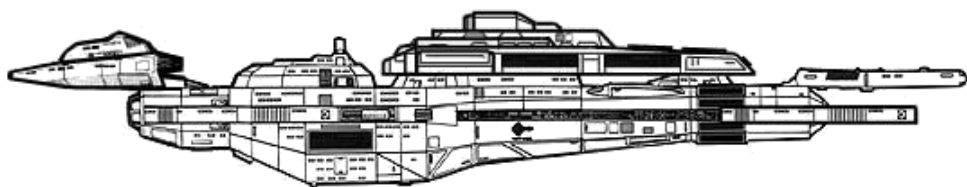



FERENGI STARSHIPS

FERENGI MARAUDER



Class: D'Kora
Type: Marauder
First Encountered: 2364
Production Base: Unknown, Ferengi Alliance
Length: 392 metres
Beam: 308 metres
Height: 88 metres

Mass: 2,270,000 metric tons
Crew: 450
Cruising Speed: Warp 6
Maximum Speed: Warp 9.6
Armament: 5 Plasma weapon arrays, 2 photon torpedo launchers, electromagnetic pulse weapon

Known Ships
D'Kora
Krayton
Kreechta

CLASS INFORMATION:

The *D'Kora*-class Marauder (equivalent of a Heavy Cruiser), is the most common capital vessel of the Ferengi Alliance. An unusual combination of trading vessel, warship and explorer, the *D'Kora's* resources include vast cargo space, strong tractor beams for recovering salvage, and powerful embedded warp nacelles.

The Marauder's plasma disruptors are designed for effective firing at longer ranges, allowing the Ferengi to deliver a crippling first blow before an opponent can return fire. The ship is also equipped with a powerful energy wave weapon which emits an electromagnetic pulse from the aft section of the engineering hull. The weapons ports and neck section can be extended, exposing the ship's sensitive areas during surrender. The *D'Kora* also carries an auxiliary craft embedded in its ventral hull.

Official first contact between the Federation and the Ferengi occurred in 2364 in the Delphi Ardu system, where the *USS Enterprise* NCC-1701-D and a Ferengi Marauder were trapped in orbit above a derelict outpost of the ancient Tkon Empire.



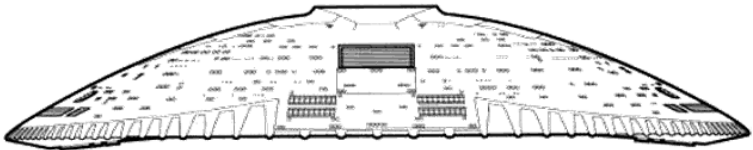
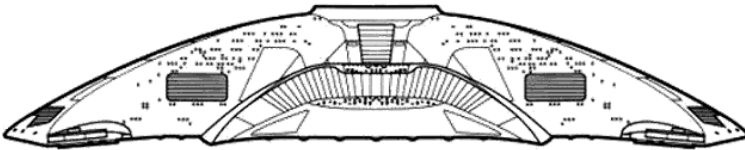
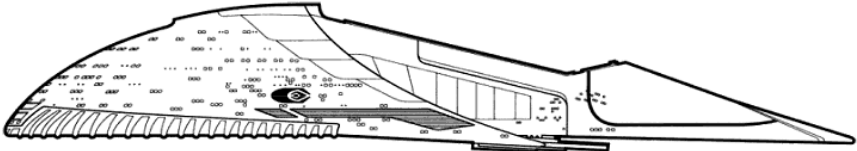
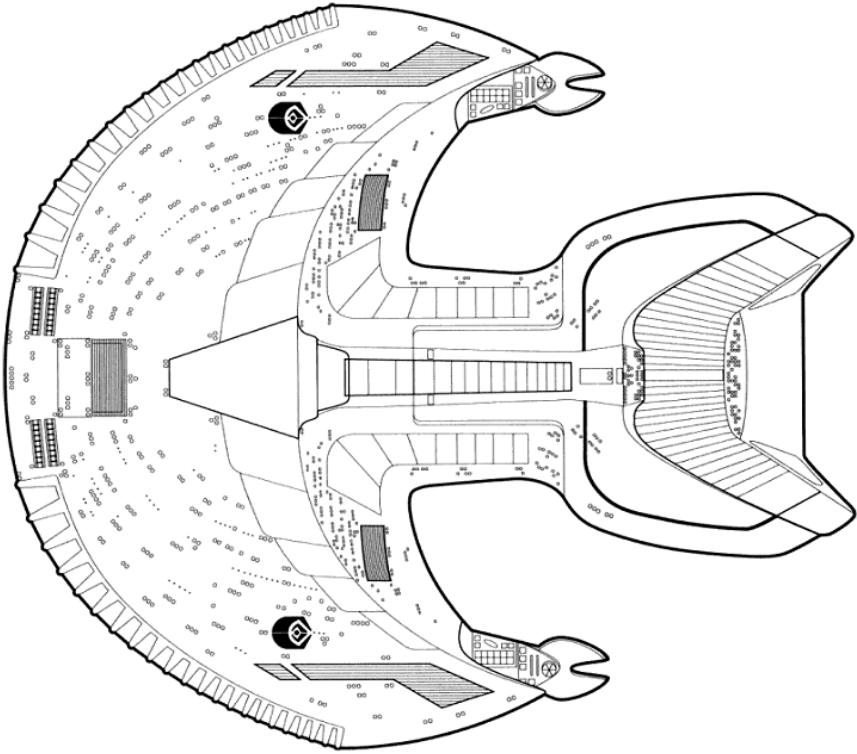



THOLIAN STARSHIPS

THOLIAN PATROL SHIP

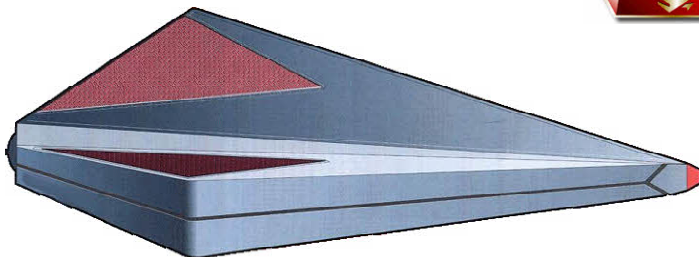

Class: Unknown

Type: Patrol Ship

First Encountered: 2268

Production Base: Unknown,

Tholian Assembly

Length: 15 metres

Beam: 6.62 metres

Height: 5.66 metres

Mass: Unknown

Crew: Unknown

Cruising Speed: Warp 3

Maximum Speed: Warp 5

Armament: 1 Plasma torpedo

launcher, 1 Tholian web

generator

Known Ships

Names unknown

CLASS INFORMATION:

The secretive and xenophobic nature of the Tholian Assembly means little is known about their vessels.

The Tholian 'web-spinner' is believed to be a development of a similar design first encountered by Earth's Starfleet over a century earlier. These small vessels, built to patrol and monitor the borders of Tholian space, were armed with plasma torpedo-like weaponry and an aft tractor emitter which, in conjunction with at least one more vessel of the type, could 'weave' a tractor web around a foe. The web could then be contracted, destroying the vessel inside.

In 2268 the *USS Enterprise* NCC-1701 encountered two Tholian vessels while trying to recover the *USS Defiant* NCC-1764 from an interphasic rift. The *Enterprise* ultimately escaped from a Tholian web but the *Defiant* was lost inside the rift.

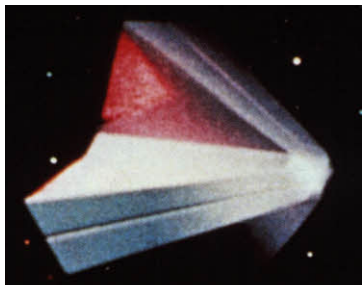

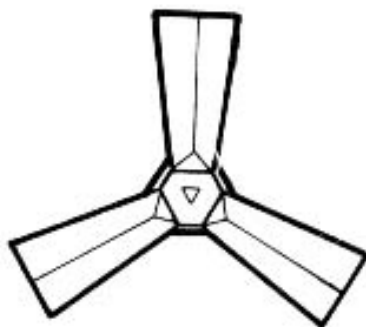
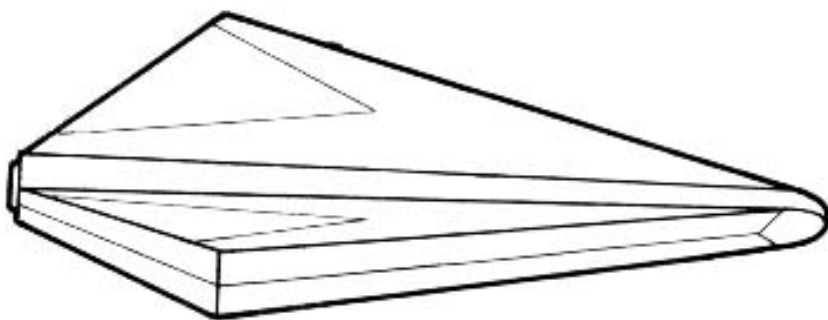
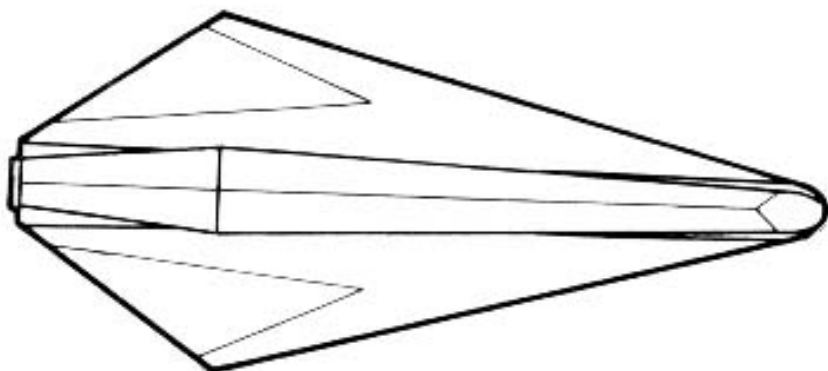

THOLIAN WARSHIP

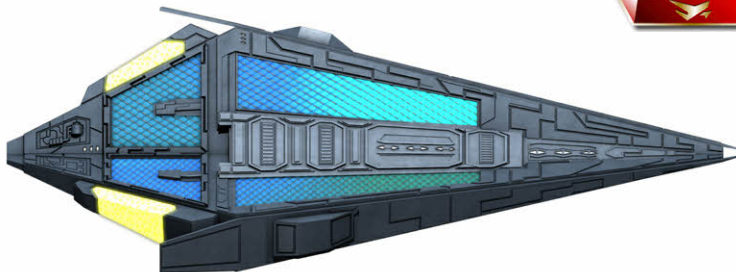

Class: Tri-Axil Delta

Type: Warship

First Encountered: 2152

Production Base: Unknown,
Tholian Assembly

Length: 15 metres

Beam: 6.3 metres

Height: 5.5 metres

Mass: Unknown

Crew: Unknown

Cruising Speed: Unknown

Maximum Speed: Unknown

Armament: 1 Plasma torpedo
launcher, 1 Tholian web
generator

Known Ships

Names unknown

CLASS INFORMATION:

The 22nd century Tholian warship was a relatively small starship with a tapered shape characteristic of Tholian designs. It was outfitted with formidable armament for its size, including an energy dampening weapon which could render some enemy vessels almost completely powerless. The interiors of Tholian ships were kept at temperatures exceeding two hundred degrees celsius to mimic the harsh, hot environment in which the Tholians lived.

Tholian ships could generate a web of energy filaments to ensnare an immobilised enemy vessel. The more ships that were used to generate the web, the faster it could be deployed. Once a web was completed it became self-generating.

In 2152, a fleet of Tholian warships attacked the Vulcan cruiser *Tal'Kir*, a number of Suliban cell ships, and the *Enterprise* NX-01, to capture a 31st century time pod.

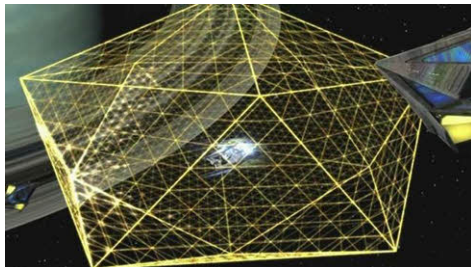
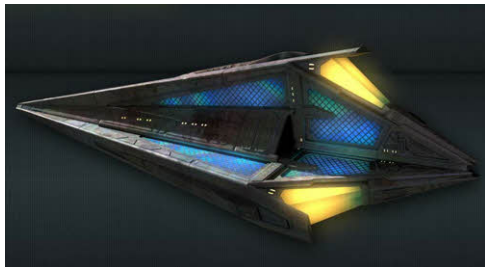

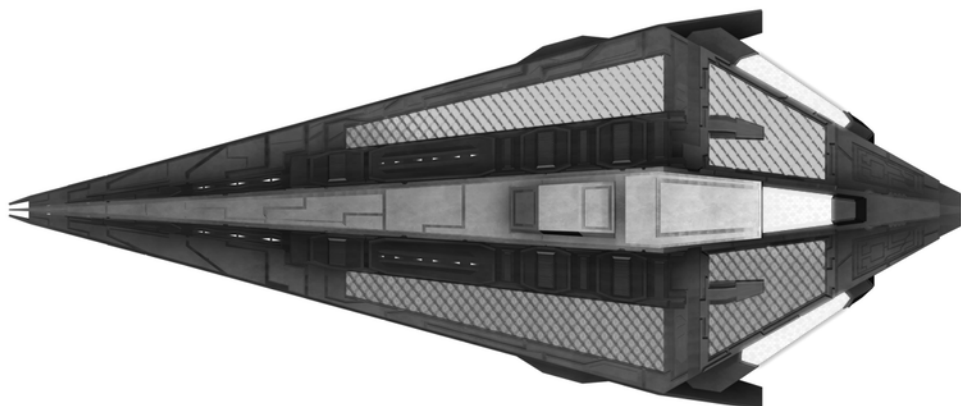
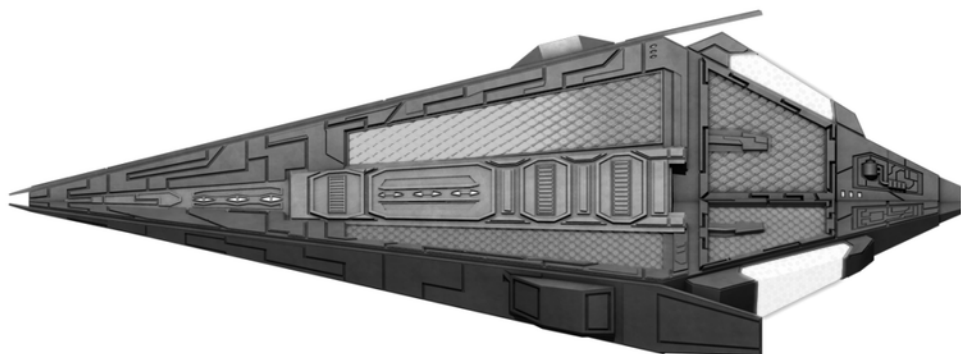

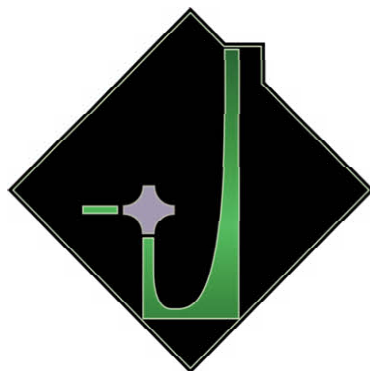

DOMINION STARSHIPS

JEM'HADAR ATTACK SHIP

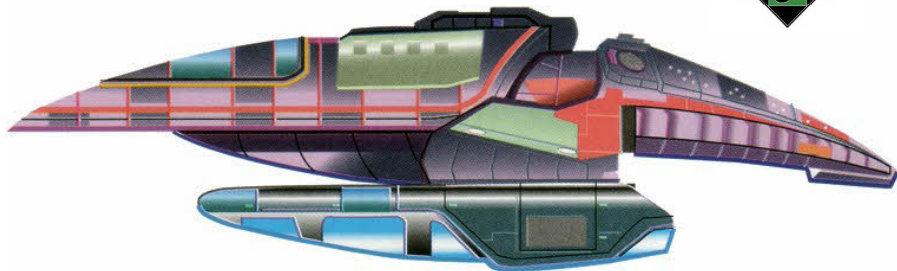
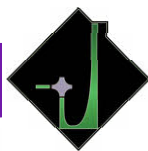

Class: Unknown
Type: Fighter/Attack Ship
First Encountered: 2370
Production Base: Unknown, Gamma Quadrant
Length: 95 metres
Beam: 103 metres
Height: 28 metres

Mass: 2,450 metric tons
Crew: 42
Cruising Speed: Warp 5
Maximum Speed: Warp 9.6
Armament: 4 Polaron beam emitters, 1 photon torpedo launcher

Known Ships
Names unknown

CLASS INFORMATION:

The Jem'Hadar attack ship was a durable, manoeuvrable craft comparable in size to a Klingon *B'rel*-class Bird of Prey, which formed the bulk of the Dominion fleet. Used as fighters, patrol ships and scouts, attack ships were equipped with phased polaron beam weapons capable of penetrating the shields of Federation starships. They were also often used for kamikaze attacks on enemy vessels.

Dominion attack ships are able to make planetfall and take-off again. Once landed, Jem'Hadar troops can egress from a large access hatch on the belly of the ship.

Attack ships are equipped with transporters capable of beaming through Federation shields, and antiproton beams (and subsequently long-range tachyon scanners) able to locate cloaked vessels. Their deflectors can repel tractor beams, and in addition to warp and impulse engines, attack ships employ a backup ion drive.



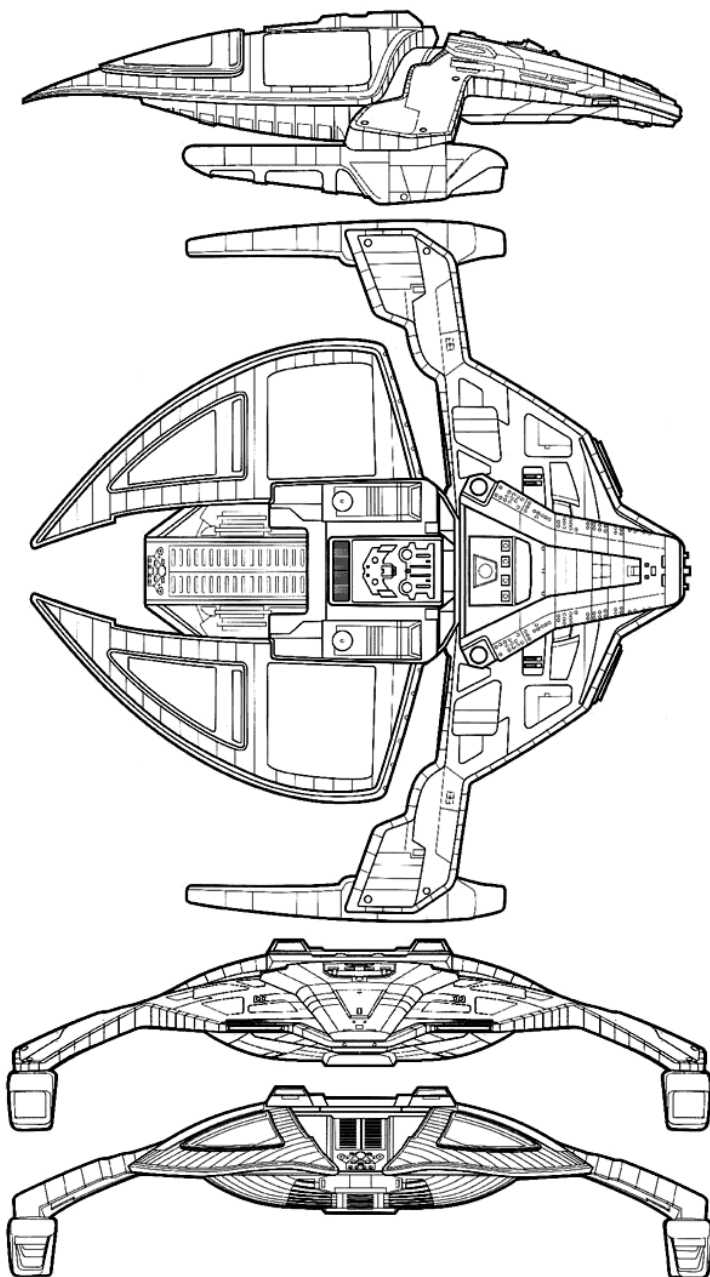

JEM'HADAR BATTLECRUISER

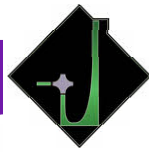

Class: Unknown
Type: Battlecruiser
First Encountered: 2373
Production Base: Unknown, Gamma Quadrant
Length: 639.75 metres
Beam: 568.44 metres
Height: 204.97 metres

Mass: 4,215,000 metric tons
Crew: 2,500
Cruising Speed: Warp 8
Maximum Speed: Warp 9.6
Armament: 6 Polaron beam emitters, 2 photon torpedo launchers

Known Ships
Tenak'talar ⚔
⚔ *Non-canon*

CLASS INFORMATION:

The Jem'Hadar battlecruiser was a powerful warship the size of a Federation *Galaxy*-class explorer, used by the Dominion for fleet engagements in the 2370s. Like the smaller Jem'Hadar attack ship, the battlecruiser is equipped with turret-mounted phased polaron beam weapons, and is more manoeuvrable than most comparably-sized enemy vessels.

The engineering section is at the rear of the ship, with the nacelles elevated on either side of the impulse drive unit. Fuel is stored in the wingtip pods. A forward housing is thought to hold the command and control systems and accommodation.

The *Tenak'talar* was the Jem'Hadar warship often utilized by Weyoun. It took part in numerous successful battles for the Dominion, including the taking of *Deep Space Nine* and the recapture of the Chin'toka system.



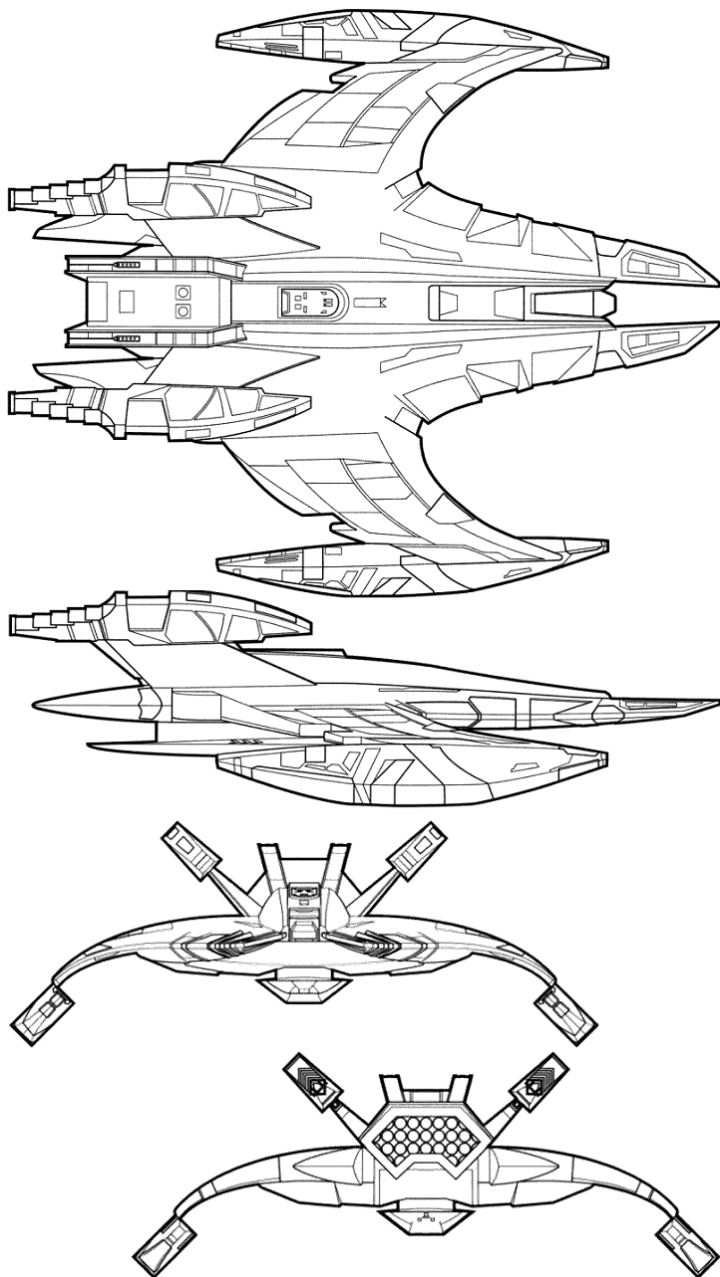

JEM'HADAR BATTLESHIP

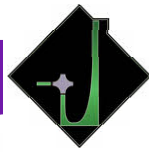

Class: Unknown

Type: Battleship

First Encountered: 2374

Production Base: Unknown,
Gamma Quadrant

Length: 1,457 metres

Beam: 982 metres

Height: 423 metres

Mass: 18,200,000 metric tons

Crew: 1,200

Cruising Speed: Warp 8

Maximum Speed: Warp 9.925

Armament: 2 Heavy-duty
polaron pulse cannons, 38
polaron beam emitters, 9 photon
torpedo launchers

Known Ships

Names unknown

CLASS INFORMATION:

The Jem'Hadar or Dominion battleship was a large warship first encountered in the Alpha Quadrant midway through the Dominion War. Observations via sensor probe indicated the vessel was twice as long as a Federation *Galaxy*-class and three times as powerful.

In 2374 the *U.S.S. Valiant* NCC-74210 attempted to disable the prototype battleship by exploiting a perceived weakness in the primary support braces for the antimatter storage system. Exposure to delta radiation would theoretically cause the supports to destabilize. However the Dominion battleship was not as vulnerable as thought and the *Valiant* was destroyed with relative ease.

Jem'Hadar battleships also participated in the Battle of Cardassia at the end of the Dominion War.



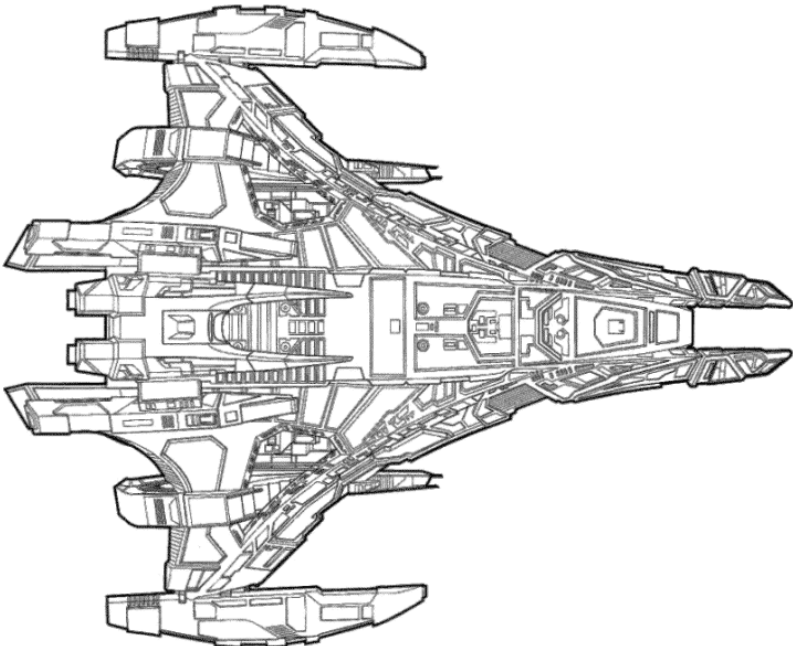
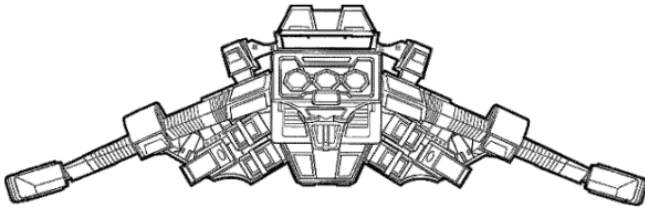
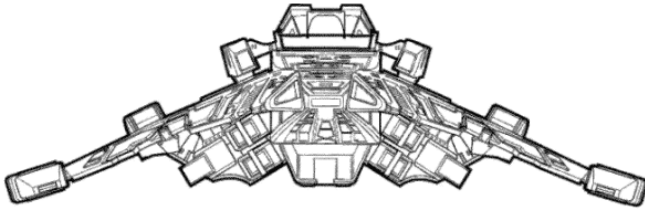
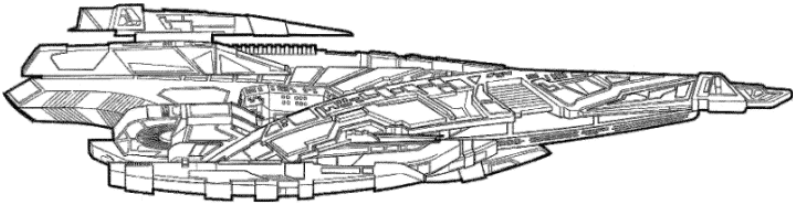

BREEN WARSHIP

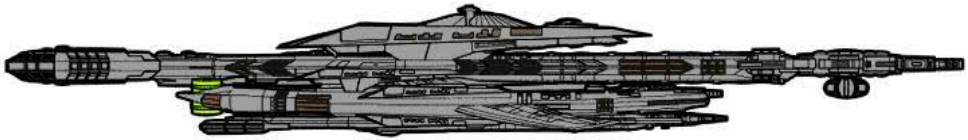

Class: Chel Grett/Gor Taan
Type: Battlecruiser
First Encountered: 2375
Production Base: Unknown, Breen Confederacy
Length: 330 metres
Beam: 263 metres
Height: 44 metres

Mass: 818,000 metric tons
Crew: 630
Cruising Speed: Warp 6
Maximum Speed: Warp 9.6
Armament: 5 Disruptor mounts, 4 photon torpedo launchers, energy dampening weapon

Known Ships

Chel Grett ϕ
Gor Taan ϕ
Tykk ϕ
 ϕ *Non-canon*

CLASS INFORMATION:

The Breen *Chel Grett*-class battlecruiser is a large long-range strike vessel that is ideal for incursion, invasion and disruption missions. The ship is made of a mixture of alloys and unique poly-organic components, and features a detachable auxiliary pod at its aft end.

Chel Grett-class warships are equipped with cloaking devices, though they are rarely found operating independently on reconnaissance missions. The design features two separate pairs of warp nacelles in the port and starboard 'spars' to generate extra power and manoeuvrability. The *Chel Grett* is armed with several disruptors and photon torpedoes, but its most devastating weapon is its energy dissipator, which can disrupt systems and electro-plasma flow throughout a starship, rendering it powerless and dead in space.

The Breen allied themselves with the Dominion in late 2375, and heralded their arrival in the war with a sneak attack on Starfleet Headquarters and San Francisco.



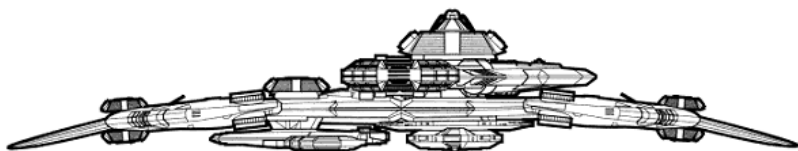
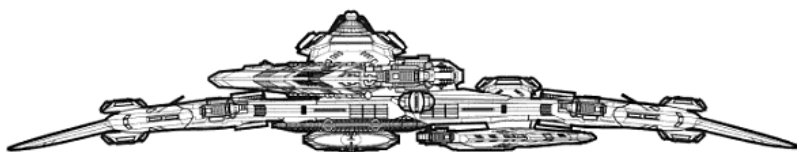
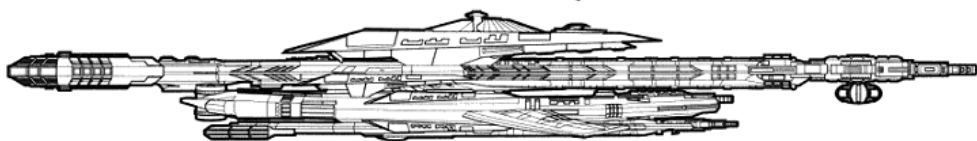
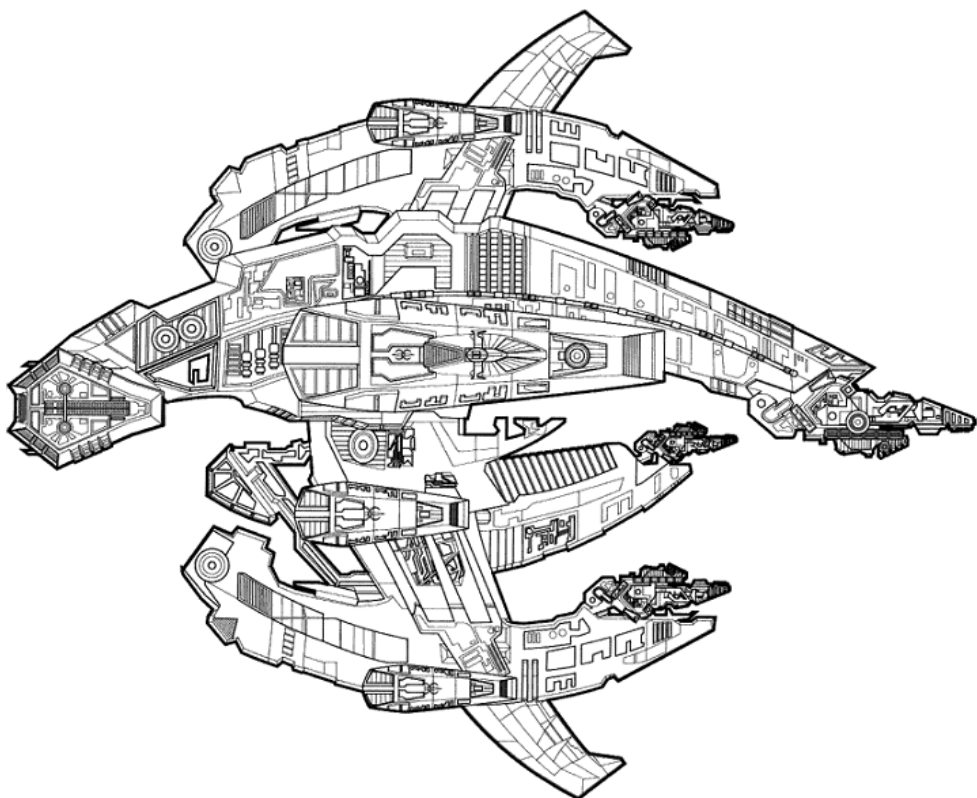

KAREMMA TRADING VESSEL

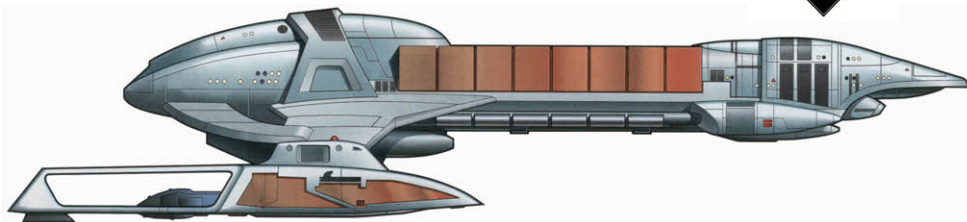
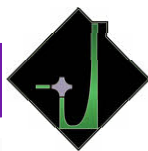

Class: Unknown
Type: Freighter
First Encountered: 2372
Production Base: Unknown,
Gamma Quadrant
Length: 388 metres
Beam: 120 metres
Height: 83 metres

Mass: 1,691,000 metric tons
Crew: 24
Cruising Speed: Warp 5
Maximum Speed: Warp 7.2
Armament: None

Known Ships
Names unknown

CLASS INFORMATION:

The Karemma trading vessel is a medium-sized starship of fairly conventional design. Utilizing standard warp drive technology, the freighter features a small matter/antimatter reactor system in the rear section of the vessel, which feeds the twin strut-mounted warp nacelles.

The central section of the ship houses eight large cargo bays, customisable to hold almost any form of merchandise. The forward section holds the navigational deflectors, a modest shield system, a small hangar deck, and a basic accommodation section. Karemma ships are not equipped with any weapons as standard.

A Karemma vessel rendezvoused with the *U.S.S. Defiant* in 2372 to discuss their trading agreement with the Ferengi, but was subsequently abandoned after being forced into the atmosphere of a nearby gas giant by two Jem'Hadar fighters.

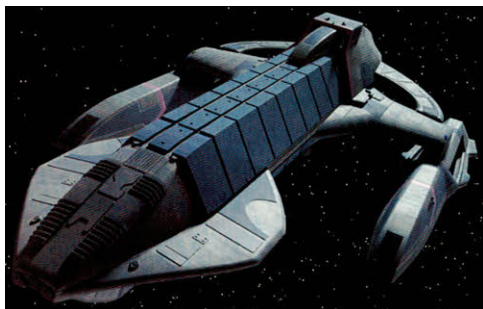

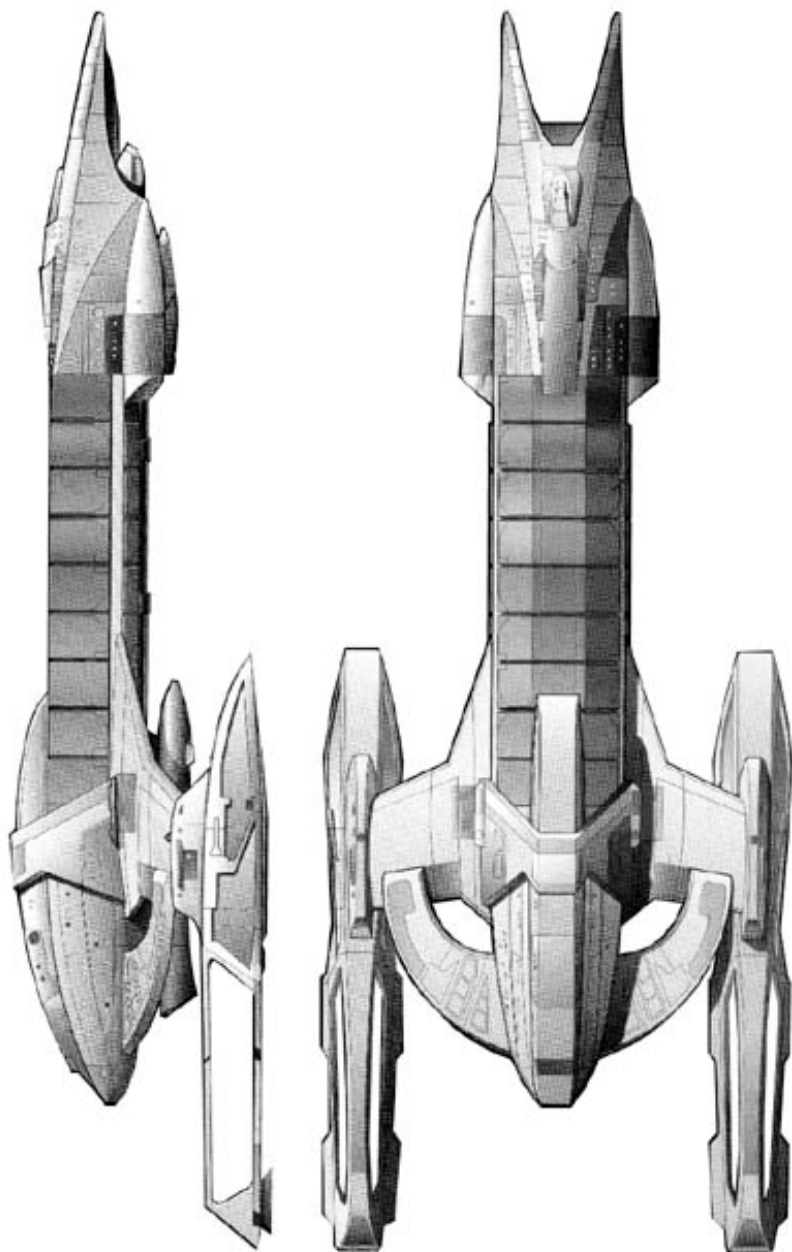

SON'A BATTLESHIP

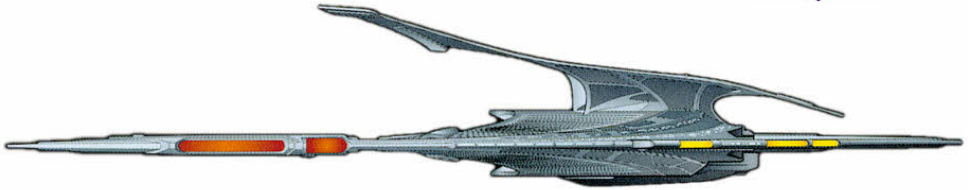

Class: Unknown
Type: Battleship
First Encountered: 2375
Production Base: Unknown
Length: 837 metres
Beam: 1065 metres
Height: 162 metres
Mass: 9,000,000 metric tons

Crew: 1,400
Cruising Speed: Warp 8
Maximum Speed: Warp 9.9
Armament: 24 Phaser banks,
6 photon torpedo launchers,
4 isolytic burst weapons

Known Ships
(Names unknown)

CLASS INFORMATION:

Son'a Battleships are amongst the most powerful vessels in the Alpha and Beta Quadrants. They are equipped with phasers, photon torpedoes and isolytic sub-space weapons - highly unpredictable charges which create tears in subspace - which are outlawed under the Second Khitomer Accords.

The forward torpedo tubes are situated in the protruding structures at the very front of the ship, with phasers mounted in the smaller 'teeth' in between. The isolytic weapon launchers form the leading edge of the curving wings, with three additional weapons arrays on the trailing edge of the upper horn-like structure. Warp vanes and primary impulse engines are housed in the wingtip structures, with additional warp field trim vanes forming the ribbed structure of the wings.

The Federation's first combat experience against Son'a Battleships came in 2374, when two of them attacked the *U.S.S. Enterprise* NCC-1701-E in the Briar Patch. One of the cruisers fired an isolytic burst, forcing the *Enterprise* to eject its warp core, before the Starfleet vessel destroyed one battleship and damaged the other.



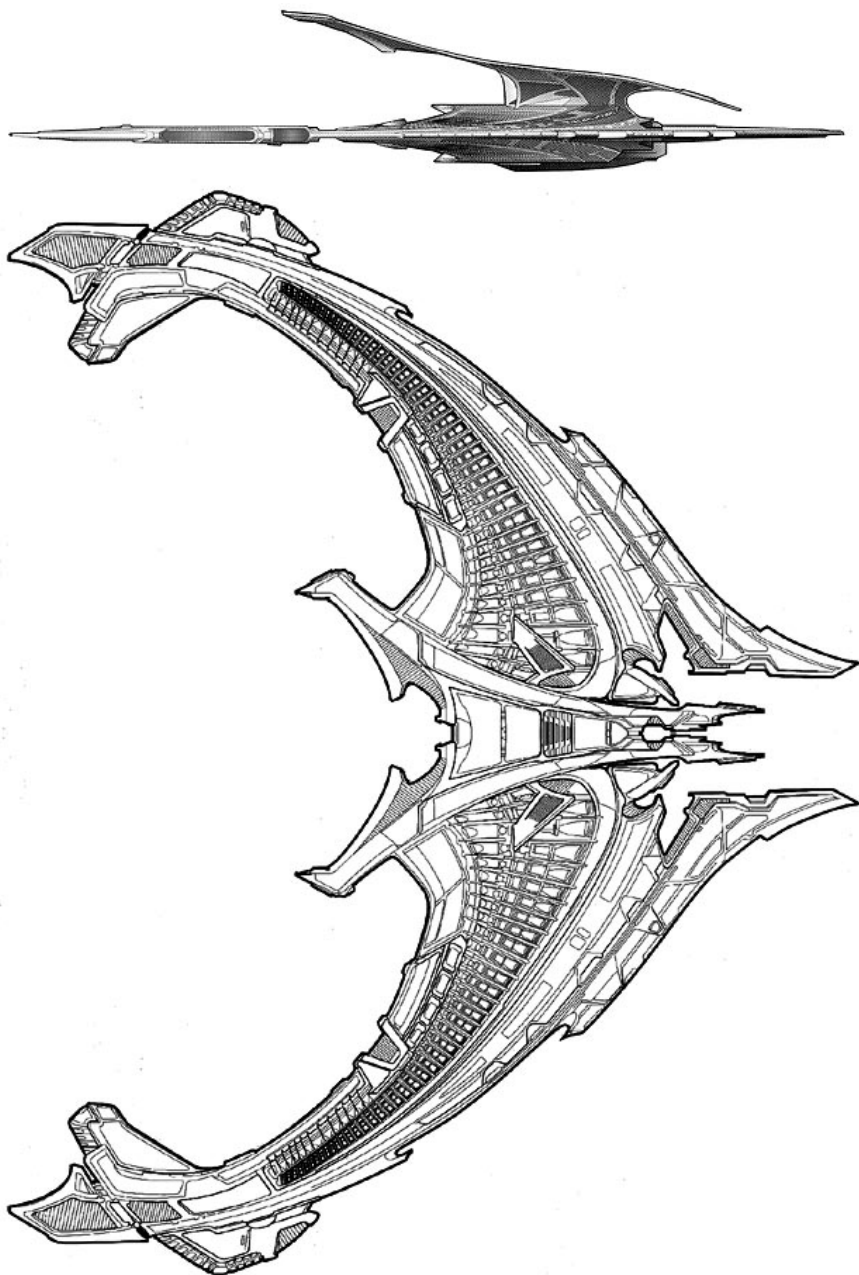

SON'A COMMAND SHIP

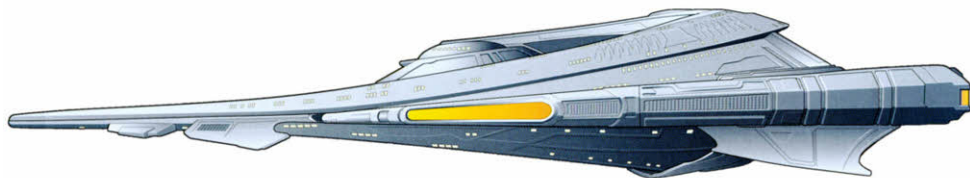

Class: Unknown
Type: Command Ship
First Encountered: 2375
Production Base: Unknown
Length: 354 metres
Beam: 276 metres
Height: 64 metres
Mass: 2,142,000 metric tons

Crew: 100
Cruising Speed: Warp 8
Maximum Speed: Warp 9.6
Armament: 8 Phaser banks,
2 photon torpedo launchers,
1 isolytic burst weapon

Known Ships
(Name Unknown)

CLASS INFORMATION:

The Son'a Command Ship was a medium-sized starship utilized by the Son'a during the late-24th century. It was sometimes designated as a destroyer.

These vessels were equipped with conventional phasers and torpedo launchers (located between the curving wings at the front of the ship), as well as an isolytic subspace burst weapon. The aft cargo hold was poorly shielded from the effects of thermolytic reactions, however. The warp nacelles were housed in the wing sections, with the impulse engines in the tips of the horns at the aft end of the vessel. Son'a Command Ships had subspace transmitter stations on deck twelve.

In 2375, Ahdar Ru'afo used one of these vessels as his flagship during his plan to relocate the Ba'ku from their adopted homeworld in the Briar Patch. Starfleet Vice Admiral Matthew Dougherty also stayed aboard this vessel while working with Ru'afo.



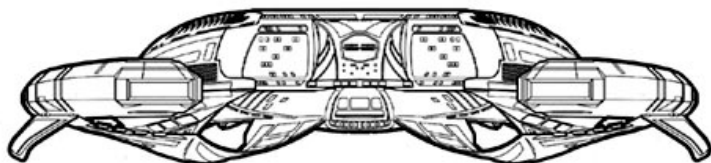
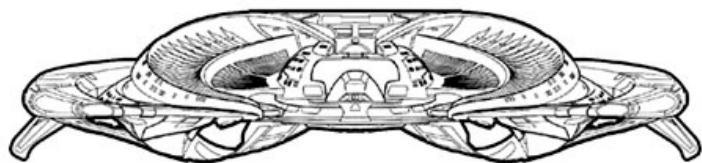
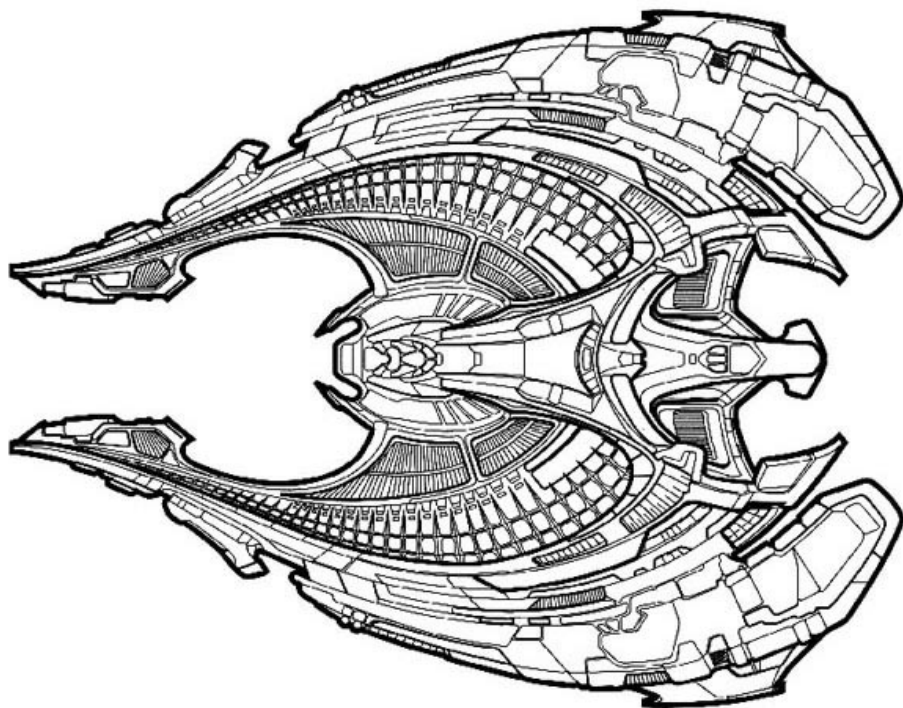
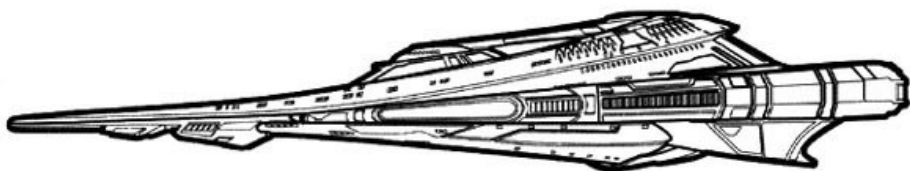



BORG STARSHIPS

BORG CUBE

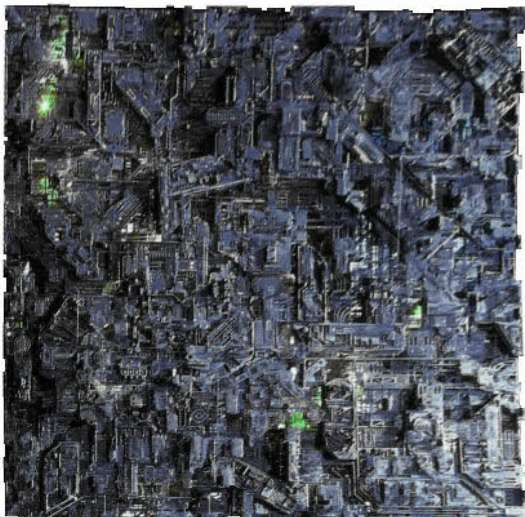

Class: Cube
Type: Assimilation Platform
First Encountered: 2365
Production Base: Borg Unicomplex, Delta Quadrant
Length: 3,040 metres
Beam: 3,040 metres
Height: 3,040 metres
Mass: 90,000,000 metric tons
Crew: 64,000
Cruising Speed: Warp 9.6
Maximum Speed: Warp 9.99946 (via Transwarp)
Armament: High energy tractor beams, cutting beams, plasma torpedoes, magneto-metric guided charges

CLASS INFORMATION:

One of the most feared vessels in the known galaxy, the Borg cube is a combination of weapons platform and factory ship, designed to assimilate new technology and species and destroy all encountered opposition.

The Borg cube has a highly decentralised design - all vital systems are spread throughout the ship. Combined with a regenerative hull, this makes the ship highly resistant to damage and system failures. The cube destroyed by Starfleet at the Battle of Sector 001 in 2373 carried a sphere as a lifeboat or support vessel.

The *U.S.S. Enterprise-D* first encountered a Borg cube at System J-25 in 2365. This cube was eventually disabled after decimating 39 starships at the Battle of Wolf 359. Thousands of cubes were thought to exist in the Delta Quadrant.

Known Ships

Cube 461
Cube 630 †
Cube 1184
'Queen's Cube' †
† *Lost or destroyed*

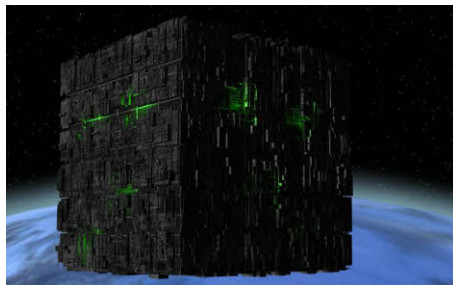
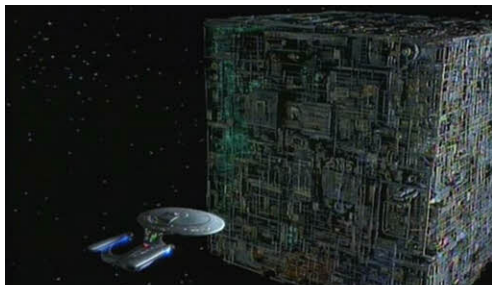

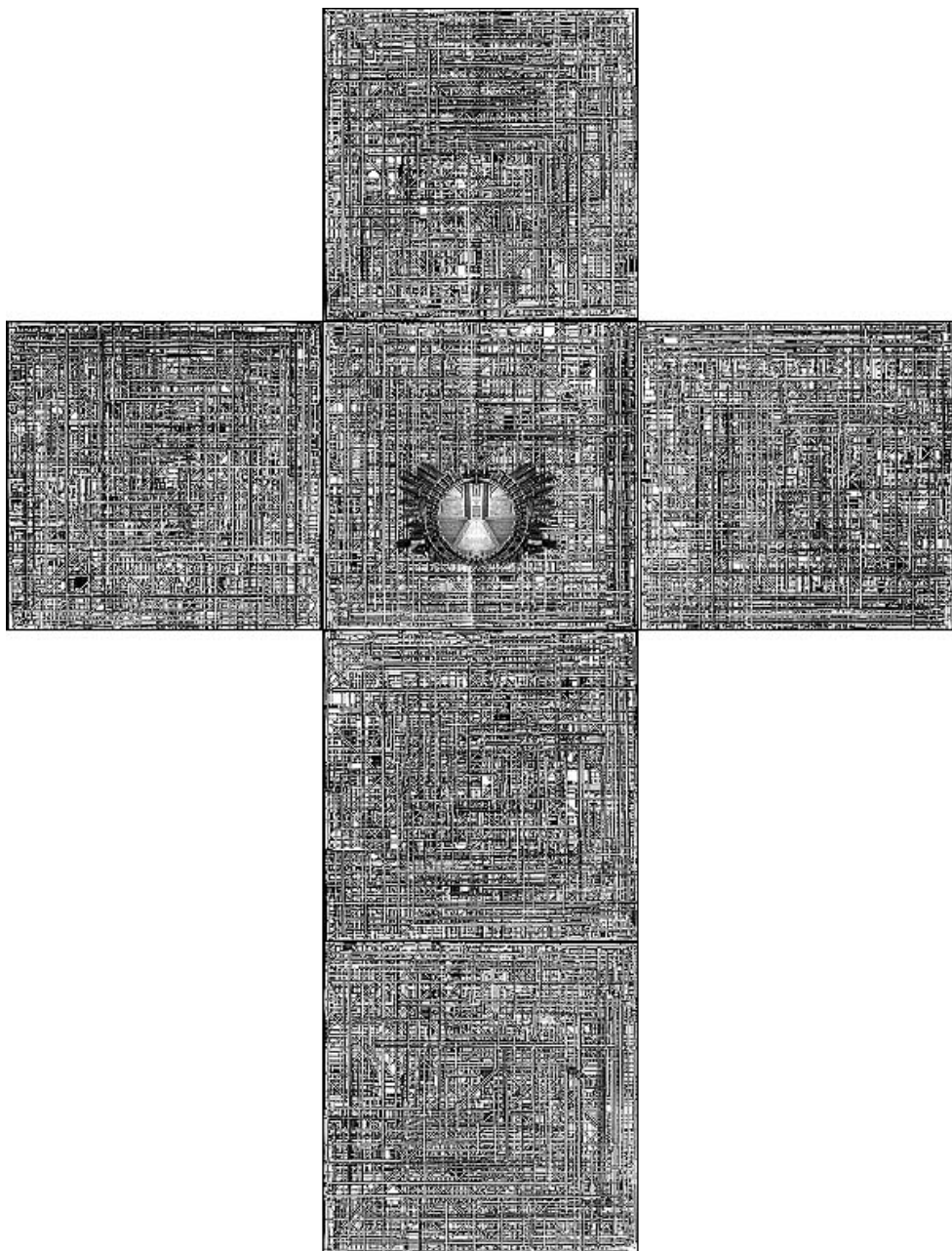

BORG QUEEN'S SHIP

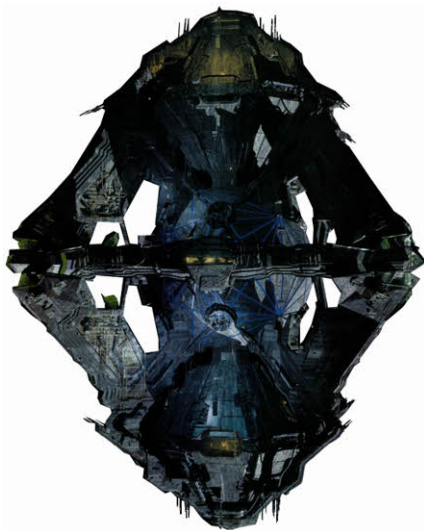

Class: Diamond
Type: Command Ship
First Encountered: 2375
Production Base: Borg Unicomplex, Delta Quadrant
Length: 820.4 metres
Beam: 820.4 metres
Height: 820.4 metres
Mass: 498,300 metric tons
Crew: Unknown
Cruising Speed: Unknown
Maximum Speed: Unknown (Transwarp)
Armament: High energy particle beam emitters, cutting beam, photonic missiles

CLASS INFORMATION:

The Borg Queen command ship, or diamond, is a mobile command centre for the Borg Queen, allowing her to coordinate the actions of the entire Borg collective while keeping her protected when travelling to and from the Unicomplex. The ship itself can be integrated into the Unicomplex structure.

Like other Borg vessels, the diamond features transwarp coils enabling it to open and enter the Borg's network of transwarp conduits. The command ship is heavily shielded. A central chamber houses the queen, and this is surrounded by multiple nodes which act as communication relays and shield matrix generators.

In 2375 the *U.S.S. Voyager* destroyed a Borg diamond by collapsing a transwarp conduit while the command ship attempted to re-emerge into normal space.

Known Ships
Designations unknown



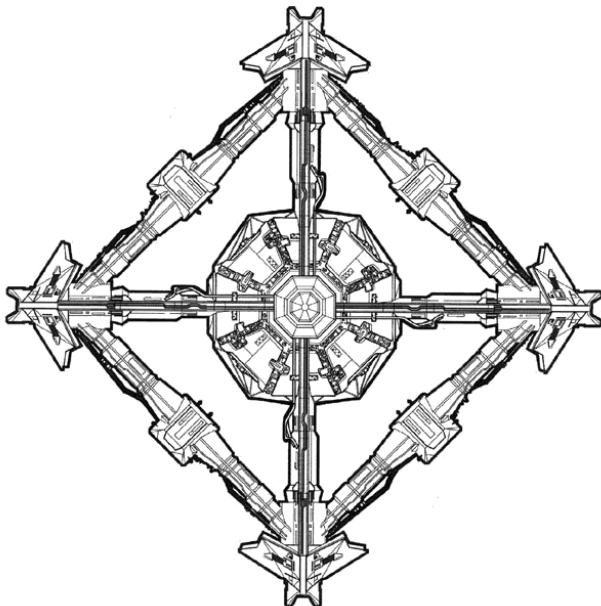
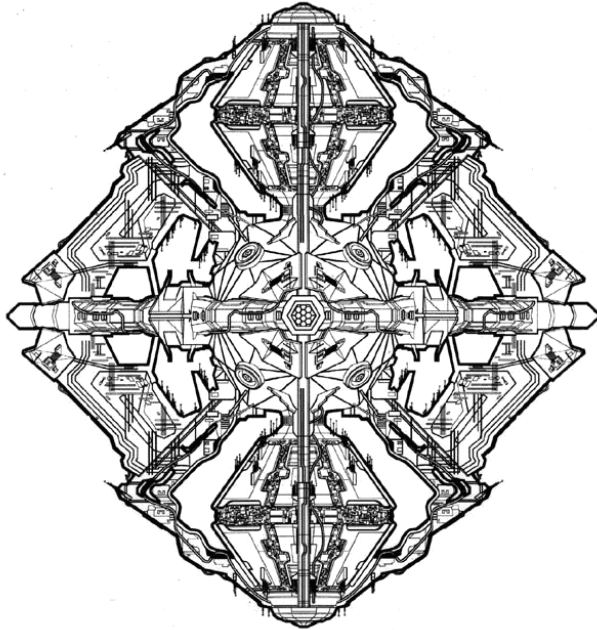

BORG PROBE

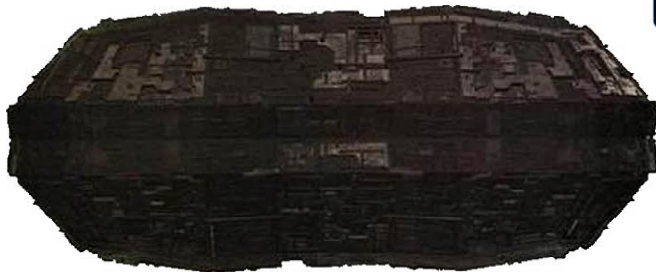

Class: Probe

Type: Scout

First Encountered: 2375

Production Base: Borg
Unicomplex, Delta Quadrant

Length: 360 metres

Beam: 100 metres

Height: 60 metres

Mass: 8,000 metric tons

Crew: Unknown

Cruising Speed: Unknown

Maximum Speed: Unknown
(Transwarp)

Armament: Particle beam
emitters

Known Ships

Designations unknown

CLASS INFORMATION:

The Borg probe was a type of small starship used by the Borg, apparently to scout low-resistance targets. The craft is similar in size to a Federation *Intrepid*-class starship, and not as well armed as most larger Borg vessels. However, like other Borg ships the probe is equipped with transwarp coils enabling it to access the Borg's network of transwarp conduits.

The *U.S.S. Voyager* NCC-74656 encountered a Borg probe in the Delta Quadrant in mid-2375. The crew attempted to disable it by beaming a photon torpedo aboard, but it detonated near the power matrix and destroyed the ship.



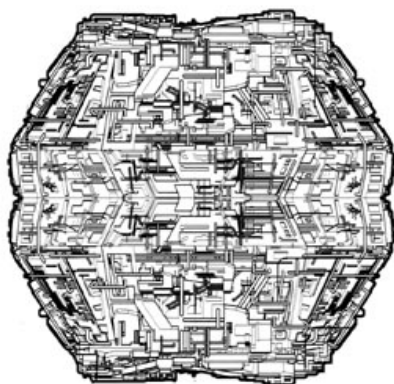
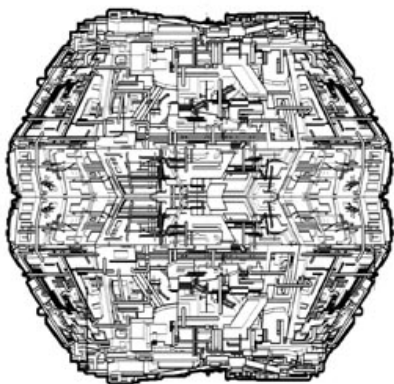
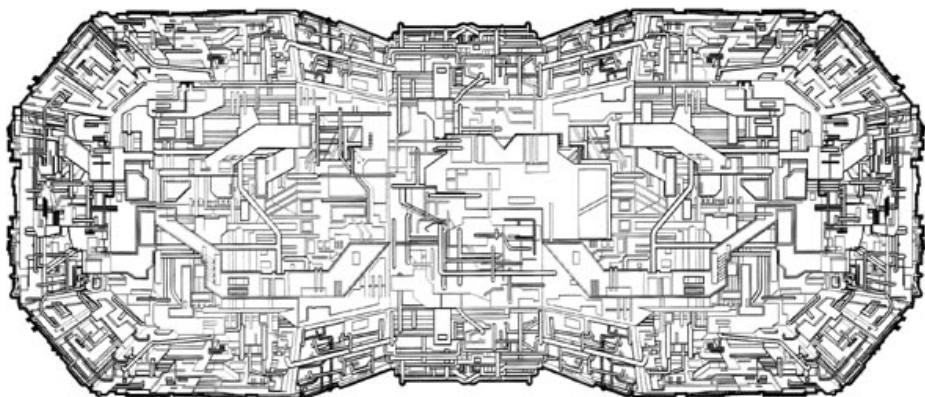
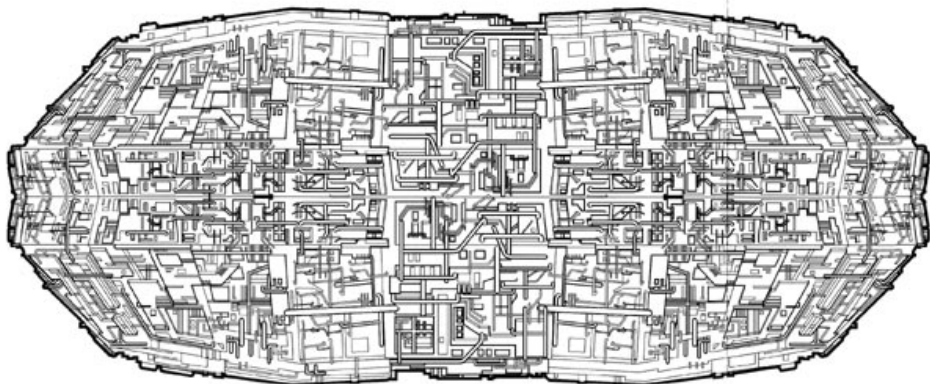

BORG SPHERE



Class: Sphere
Type: Long-range Tactical Vessel
First Encountered: 2375
Production Base: Borg Unicomplex, Delta Quadrant
Length: 457 metres
Beam: 457 metres
Height: 457 metres
Mass: 5,070,000 metric tons
Crew: 11,000
Cruising Speed: Warp 9.4
Maximum Speed: Warp 9.9999 (via Transwarp)
Armament: Particle beam emitters, cutting beams, photonic missiles

CLASS INFORMATION:

The Borg sphere is a spherical starship sometimes designated as a long-range tactical vessel. A sphere can operate independently or be carried aboard the much larger Borg cube as an escape and support vessel. Borg spheres have transwarp capability and ablative and regenerative hull armour.

A sphere has no visible living quarters, engineering section or propulsion systems. The sphere is also considerably weaker than the cube, and a 'lifeboat' sphere was destroyed by the *U.S.S. Enterprise* NCC-1701-E in 2373 with relative ease using quantum torpedoes. This sphere was able to create a temporal vortex to travel back to the year 2063. The *U.S.S. Voyager* also destroyed a sphere using a transphasic torpedo on its return to Earth in 2378.

Known Ships

'Queen's Sphere' †
Sphere 634 †
Sphere 878 †
† *Lost or destroyed*

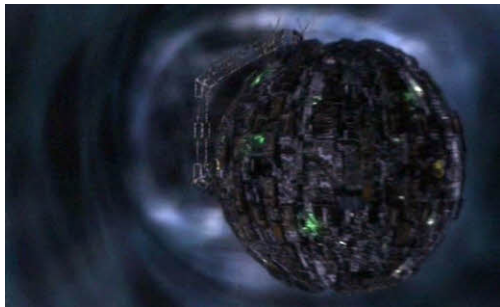

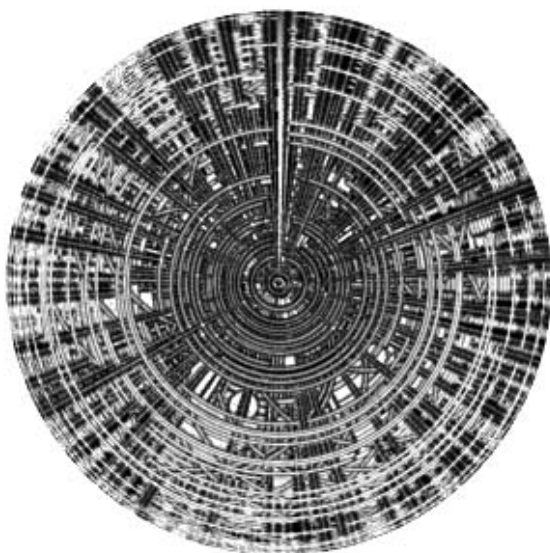
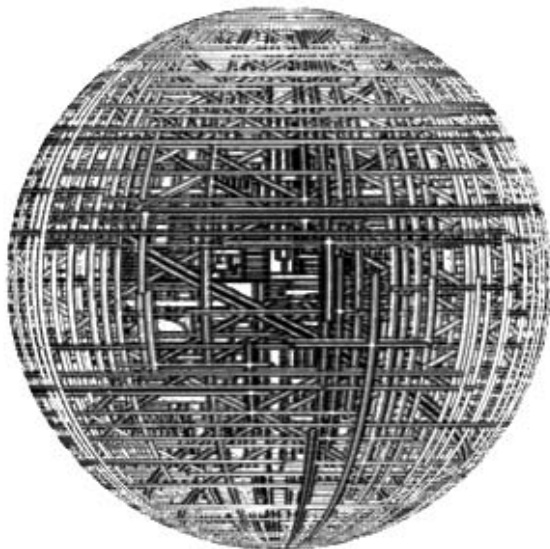

BORG TACTICAL CUBE

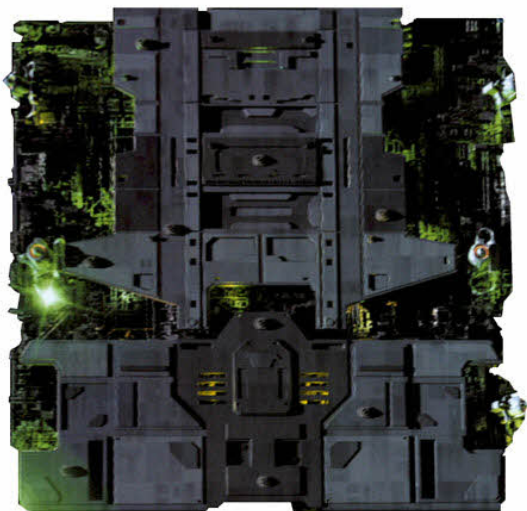

Class: Class-4 Tactical Cube
Type: Combat Vessel
First Encountered: 2365
Production Base: Borg Unicomplex, Delta Quadrant
Length: 3,040 metres
Beam: 3,040 metres
Height: 3,040 metres
Mass: 90,000,000 metric tons
Crew: 64,000
Cruising Speed: Unknown
Maximum Speed: Unknown (Transwarp)
Armament: High energy tractor beams, particle beams, cutting beams, photonic missiles

CLASS INFORMATION:

The Borg tactical cube - designated *Class-4* by Starfleet - was a heavily armed vessel used by the Borg Collective. While of a similar size, the tactical cube differs from the standard Borg cube in several ways, the most notable being the extensive armour that covers a large portion of the outer hull. The interior architecture is also distinctly different from that of a standard cube.

The tactical cube's central plexus is protected by multi-regenerative security fields.

Only one such vessel has thus far been observed by Starfleet - by the *USS Voyager* in 2376. This tactical cube was later caused to self-destruct by the Borg Queen during a brief civil war within the Collective.

Known Ships

Tactical Cube 138 †
† *Lost or destroyed*

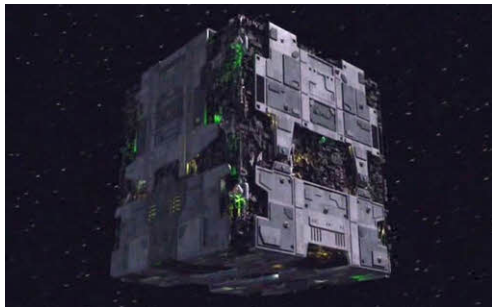

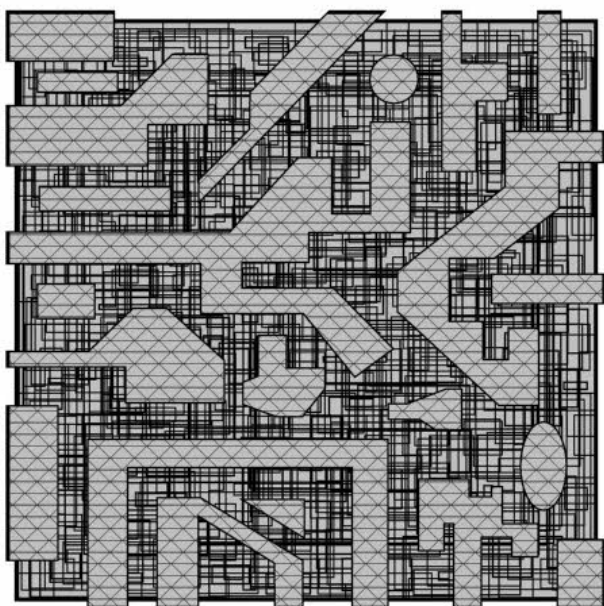
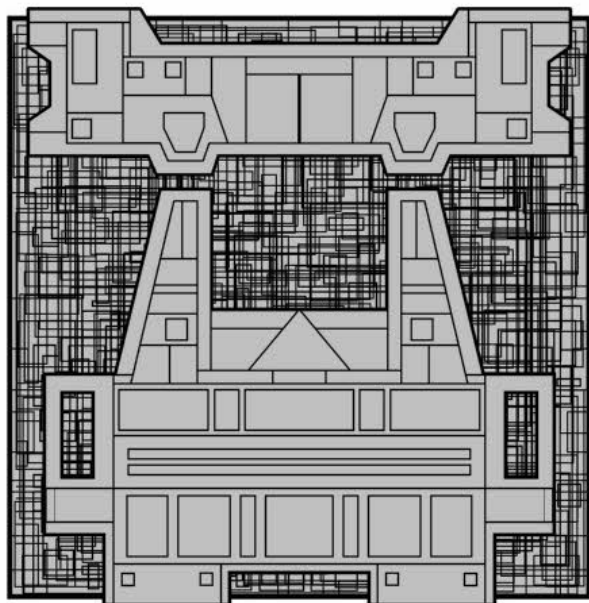

BORG TYPE 03



Class: Type 03
Type: Minelayer/Transwarp prototype
First Encountered: 2369
Production Base: Unknown
Length: 1,200 metres
Beam: 1,670 metres
Height: 676 metres

Mass: 500,000,000 metric tons
Crew: Unknown
Cruising Speed: Warp 9.9
Maximum Speed: Warp 9.99999837 (via Transwarp)
Armament: Particle beam emitters, photonic missiles, multi-kinetic neutronic mines

Known Ships
Renegade Borg Ship †
† *Lost or destroyed*

N.B. Front view shown above

CLASS INFORMATION:

Designated by Starfleet as the Borg *Type 03*, only one example of this class of Borg starship has been encountered, when in 2369 a group of rogue Borg led by the android Lore began attacking Federation outposts and colonies in several outlying sectors.

The unusual asymmetrical design was totally unlike the previously encountered Borg cube and Borg scout. However, the vessel was still heavily armed and massively armoured, and capable of great destructive power.

The configuration of the vessel is the same as that of a Borg multi-kinetic neutronic mine, prompting speculation that the ship itself may be a minelayer. Alternatively it may have been a prototype testbed for the Borg's transwarp technology, though subsequent revelations of earlier Borg activity would appear to discount this.



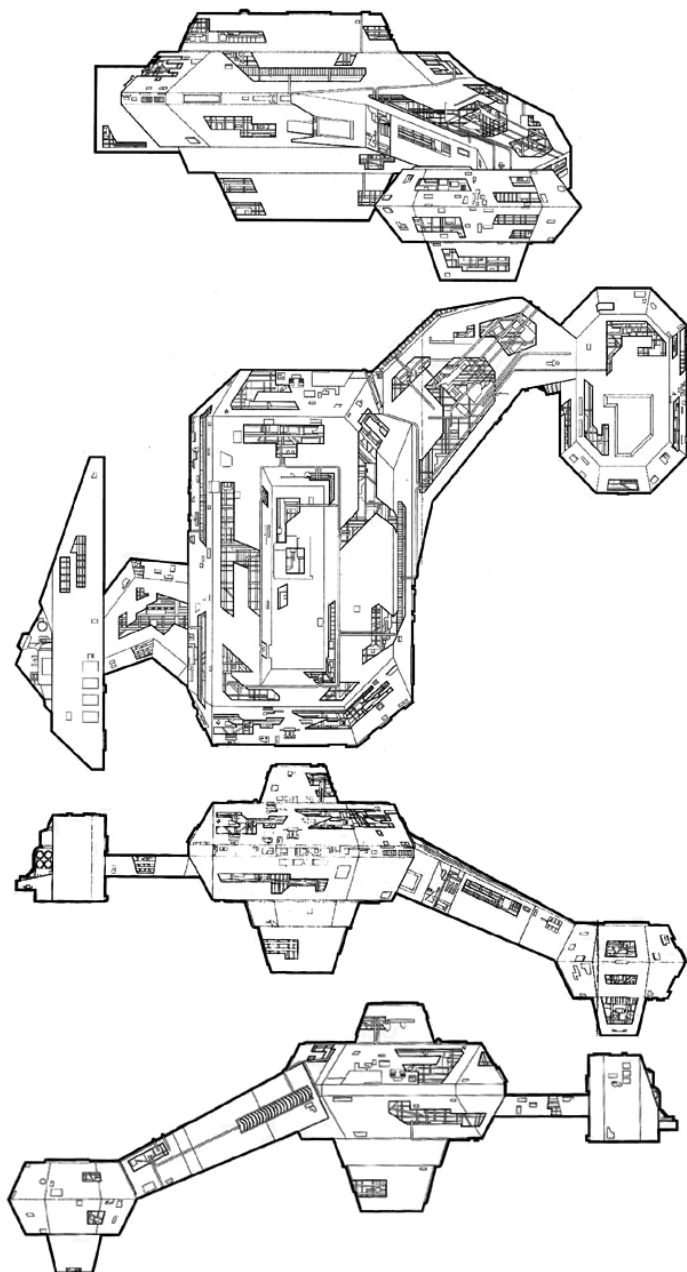

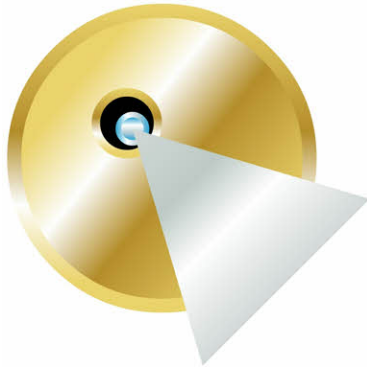

VULCAN STARSHIPS

APOLLO CLASS

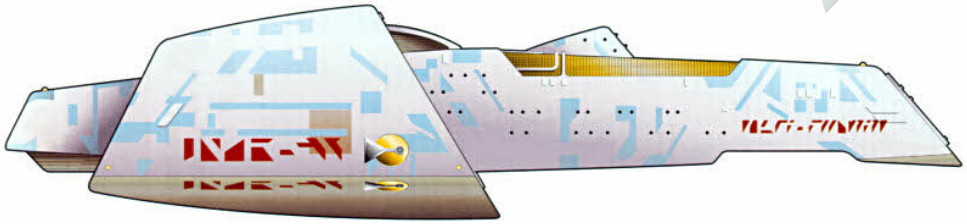

Class: Apollo
Type: Light Cruiser/Transport
Commissioned: 2325
Production Base: 40 Eridani A
Fleet Yards, Vulcan
Length: 170 metres
Beam: 91 metres
Height: 36 metres

Mass: 147,600 metric tons
Crew: 217
Cruising Speed: Warp 5
Maximum Speed: Warp 9.6
Armament: 2 Type VIII phaser
arrays, 1 photon torpedo
launcher

NCC	Known Ships (USS)
11638	Agamemnon
11574	Ajax
12537	Clement
11672	Gage †
17938	* T'Pau †
	* NSP registry
	† Lost or destroyed

CLASS INFORMATION:

The *Apollo*-class was designed by Vulcan engineers and therefore has an unusual appearance for a Starfleet vessel. The aft section of the hull is surrounded by a trapezoidal structure which contains the ship's warp engines.

The *Apollo*-class is the smallest of Starfleet's light cruisers. Its primary role is to transport troops and other personnel through dangerous areas of space. While not heavily armed, it is usually fast and manoeuvrable enough to avoid or outrun trouble. In times of conflict the *Apollo* may also play a secondary support role.

The *Apollo*-class *T'Pau* NSP-17938 was a civilian Vulcan transport, decommissioned in 2364, and later sent to Surplus Depot Z15 at Qualor II. In 2368, the vessel was refurbished by the Romulans and used as part of a bogus peace convoy, in their failed attempt to conquer Vulcan.

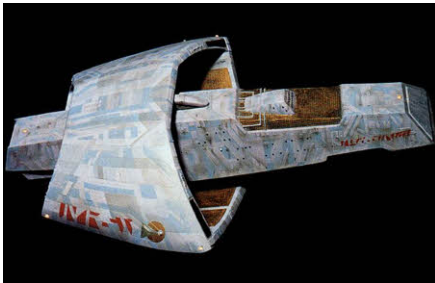

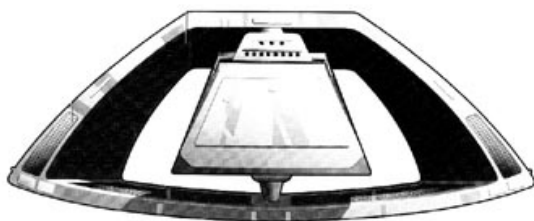
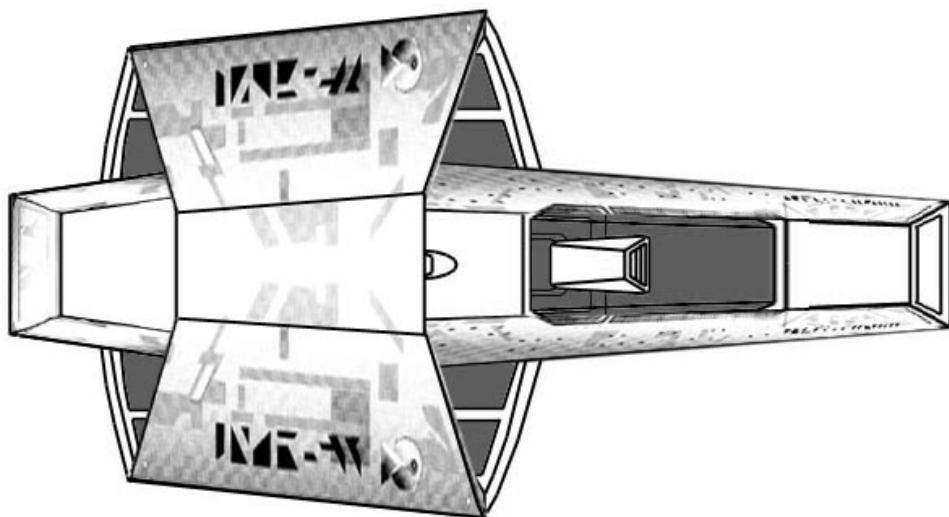
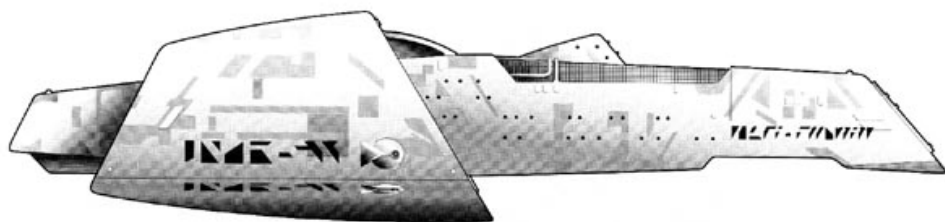

D'KYR CLASS

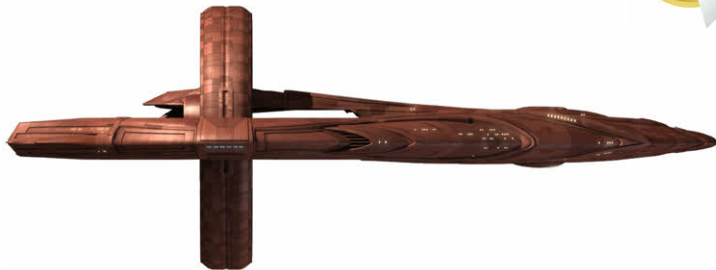

Class: D'Kyr

Type: Combat Cruiser

First Encountered: 2148

Production Base: 40 Eridani A
Construction Yards, Vulcan

Length: 600 metres

Beam: 286 metres

Height: 221 metres

Mass: 4,670,000 metric tons

Crew: 147

Cruising Speed: Warp 6

Maximum Speed: Warp 7

Armament: 6 Particle cannons,
4 photonic torpedo launchers

Known Ships

D'Kyr

Tal'Kyr

Seleya †

† *Lost or destroyed*

CLASS INFORMATION:

The *D'Kyr*-class was a type of combat cruiser operated by the Vulcan High Command during the mid-22nd century.

As with most Vulcan ships, the *D'Kyr* utilized an annular warp-drive. This was mounted inside a circular split in the ship's hull. A small auxiliary craft was housed inside the engine-ring, which could rotate through ninety degrees to allow the smaller vessel to detach or dock. The *D'Kyr* also featured a large shuttlebay in the mid-section of the ship.

Notable ships of the class included the class ship *D'Kyr*, which rendezvoused with the *Enterprise* NX-01 in 2152; and the *Seleya*, which was caught in a subspace eddy while mapping the perimeter of the Delphic Expanse in the same year. The ship was later discovered adrift inside the expanse by the *Enterprise*.



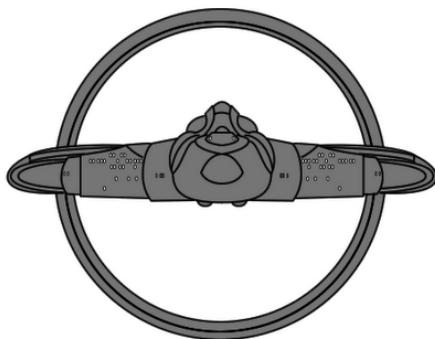
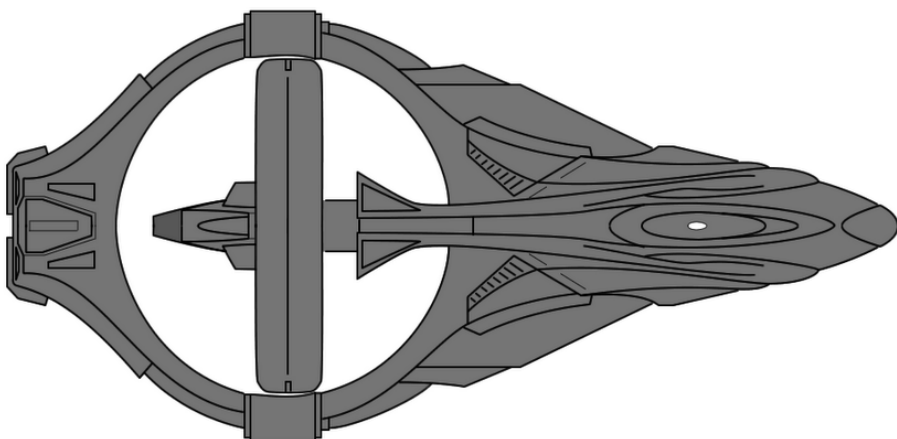
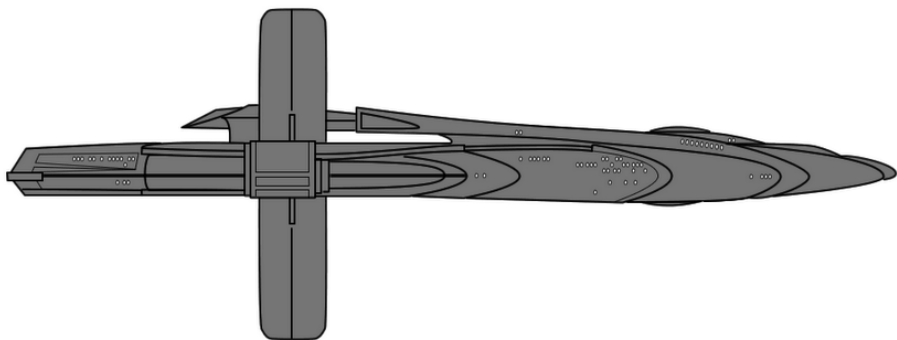

SUUROK CLASS



Class: Surak/Suurok*

Type: Science Vessel/Combat Cruiser*

First Encountered: 2151

Production Base: 40 Eridani A Construction Yards, Vulcan

Length: 600 metres

Beam: 189 metres

Height: 171 metres

Mass: 4,830,000 metric tons

Crew: 420

Cruising Speed: Warp 5.5/6*

Maximum Speed: Warp 6.5/7*

Armament: 6 Particle cannons, 4 photonic torpedo launchers

Known Ships

Ni'Var

Sh'Raan *

Surak

Suurok

Ti'Mur

* Variant

CLASS INFORMATION:

The *Suurok*-class (also often referred to as *Surak*-class) was among the fastest and most powerful vessels in the Vulcan fleet in the 2150s. As with the *D'Kyr*-class, the *Suurok* featured an annular warp drive, though in this case the engine-ring was fixed. Two versions of the class existed - the original science vessel configuration and an uprated combat cruiser variant, the latter capable of slightly higher speeds.

The *Suurok* possessed tractor beam technology which was considered classified from Earth Starfleet at the time. The tractor beam emitter was located on the lower section of the primary hull, in front of the warp drive. The class also carried much more powerful weaponry than Starfleet equivalents of the time.

Notable *Suurok*-class ships included the *Ti'Mur*, which rescued *Enterprise* NX-01 personnel from a fissure in the surface of a comet in 2151; and the *Sh'raan*, which aided the *Enterprise* in fighting off three Mazarite cruisers the following year.

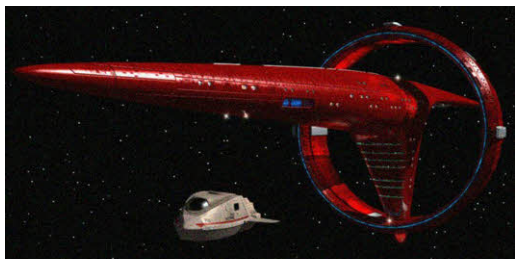

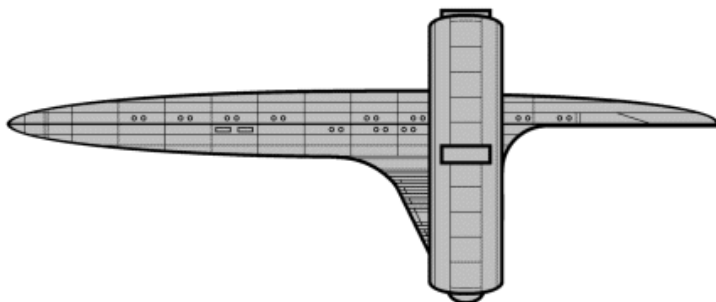
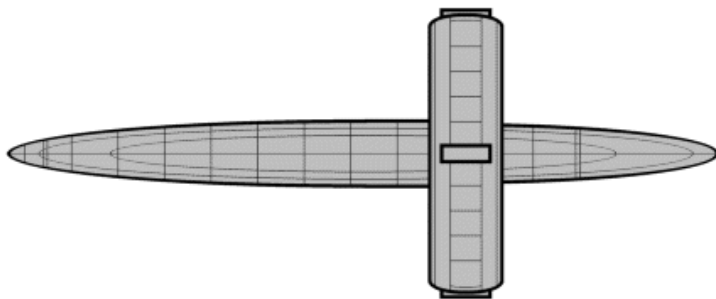

T'PLANA HATH CLASS

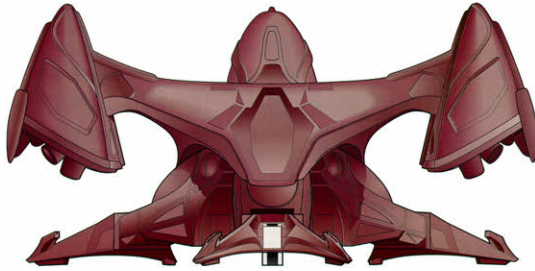
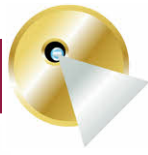

Class: T'Plana Hath

Type: Surveyor

First Encountered: 2063

Production Base: 40 Eridani A
Construction Yards, Vulcan

Length: 45 metres

Beam: 45 metres

Height: 22 metres

Mass: 600 metric tons

Crew: 3

Cruising Speed: Warp 1

Maximum Speed: Warp 1.5

Armament: Phaser arrays, photon torpedo launchers

Known Ships

T'Plana Hath

CLASS INFORMATION:

Named after the matron of Vulcan philosophy, the *T'Plana Hath*-class served as the primary exploration vessel of the Vulcan Science Institute and the Vulcan High Command in the mid-21st century. The ship was suitable for extended medium-range planetary deployment, cultural survey, and clandestine observation missions.

The *T'Plana Hath*'s warp drive was around twice as fast as that of the first human warp engine, at half the size. Sublight propulsion was provided by three ion-powered impulse engines, and the three landing feet folded out from the engine pods. A single dorsal hatch with an extendable ramp provided egress.

On April 5th 2063, while passing through the Sol system, the *T'Plana Hath* detected Dr. Zefram Cochrane's first warp flight aboard the *Phoenix*. The ship landed in Bozeman, Montana, initiating humanity's first official contact with an alien species.



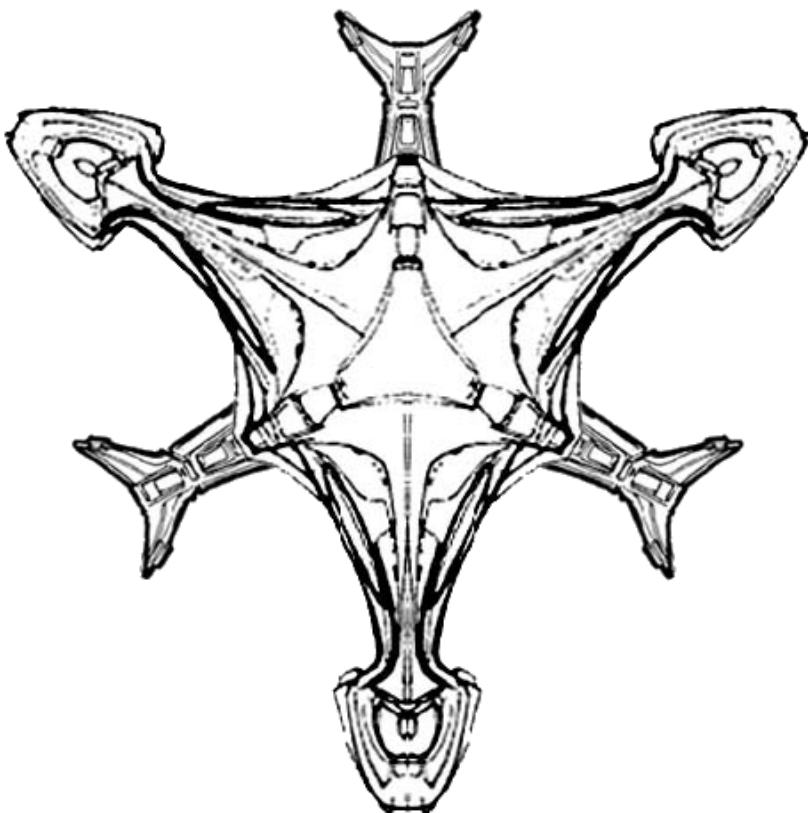
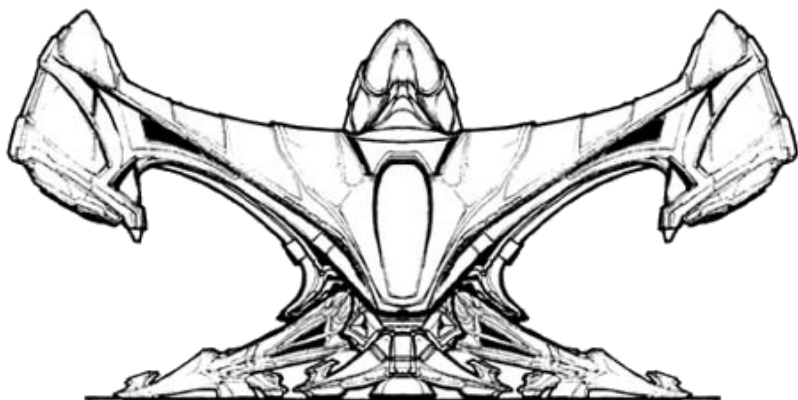

VAHKLAS CLASS



Class: Vahklas
Type: Transport/Light Cruiser
First Encountered: 2151
Production Base: 40 Eridani A
Construction Yards, Vulcan
Length: 110 metres
Beam: 49 metres
Height: 35 metres

Mass: 4,210 metric tons
Crew: 10
Cruising Speed: Warp 5
Maximum Speed: Warp 5.5
Armament: 2 Particle cannons,
1 photonic torpedo launcher

Known Ships
Vahklas

CLASS INFORMATION:

The *Vahklas*-class was a type of Vulcan transport used in the early 22nd century. The *Vahklas* sported distinctive curving warp nacelles - a design feature which would eventually progress into the full ring structure of later Vulcan vessels.

By the midpoint of the century the *Vahklas*-class was considered obsolete, though a handful of ships remained in use by civilians. However, by 2154 a number of *Vahklas*-class vessels had been refitted and reactivated by the Vulcan High Command. Some of these modified cruisers took part in the Battle of Andoria.

The *Enterprise* NX-01 encountered the *Vahklas* while charting the Arachnid Nebula in 2151. The passengers and crew claimed to be V'tosh ka'tur - Vulcans who disagreed with many of Surak's teachings and did not repress their emotions.



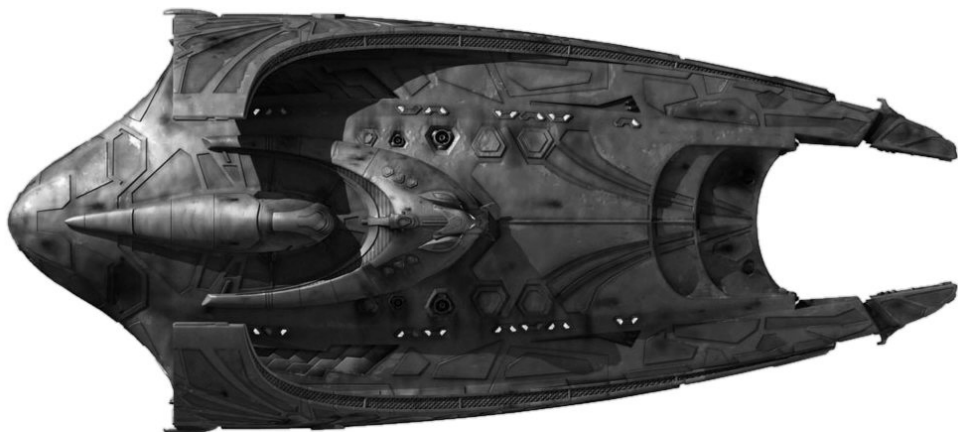



ANDORIAN STARSHIPS

KUMARI CLASS

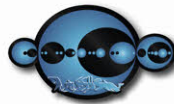

Class: Kumari

Type: Battlecruiser

First Encountered: 2152

Production Base: Epsilon Indi
Construction Yards, Andoria

Length: 360 metres

Beam: 183 metres

Height: 52 metres

Mass: 80,000 metric tons

Crew: 86

Cruising Speed: Warp 5.5

Maximum Speed: Warp 5.9

Armament: 4 Particle cannons,
3 photonic torpedo launchers

Known Ships

Kumari †

† *Lost or destroyed*

CLASS INFORMATION:

The *Kumari*-class battlecruiser was the mainstay of the Andorian Imperial Guard's fleet in the 22nd century. The ship's hull was composed of duranium and featured a long central spine with a forward crew module. The warp nacelles were mounted on the wing structures to port and starboard, with large impulse engines at the stern.

Kumari-class ships were armed with particle cannons, and utilized shield technology. Additional equipment included transporters, tractor beams, and large cargo and shuttle bays on the ventral side of the ship which could be shielded to protect against radioactive cargo.

The lead vessel, *Kumari*, was named after the first ice cutter to circumnavigate Andoria, and was commanded by Shran from 2142. The *Kumari* was destroyed by a Romulan drone ship posing as a Tellarite vessel, while escorting the Andorian ambassador to a trade conference on Babel in November 2154.



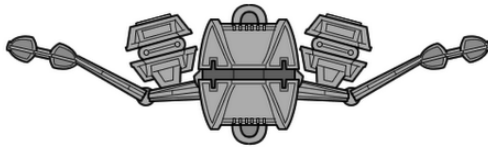
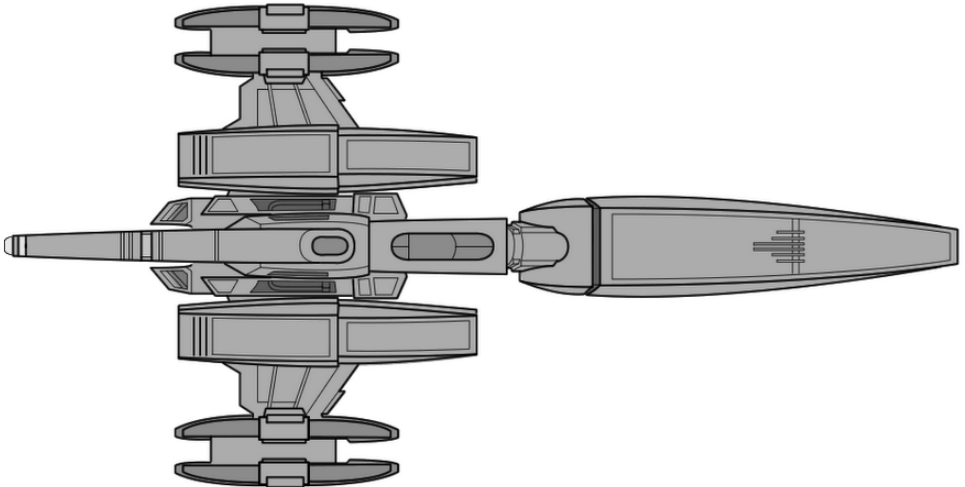
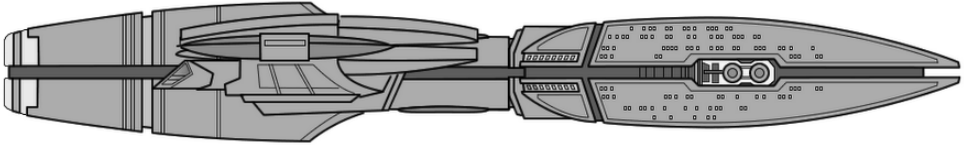



SULIBAN STARSHIPS

CELL SHIP (SHORT)



Class: Cell Ship (Short)

Type: Fighter

First Encountered: 2151

Production Base: Unknown,
Sector 3641

Length: 2.6 metres

Beam: 2.6 metres

Height: 2.53 metres

Mass: 7 metric tons

Crew: 1

Cruising Speed: Warp 5

Maximum Speed: Unknown

Armament: 1 Particle cannon

Known Ships

Names unknown

CLASS INFORMATION:

The most numerous ship type of the Suliban Cabal during the mid-22nd century, short *cell ships* were typically piloted by a single individual. They were armed with a single high-yield particle beam weapon and could be equipped with a cloaking device and tractor beam.

Cell ships could link together to create larger structures, such as a helix, as well as connect to a salvage ship. They were capable of speeds in excess of warp five, and usually travelled in large groups along with their longer counterparts.

The *Enterprise NX-01* discovered hundreds of *cell ships* docked to a Suliban helix space station during its maiden mission in 2151. The *Enterprise* subsequently captured a short *cell ship* while attempting to rescue the Klingon, Klaang.

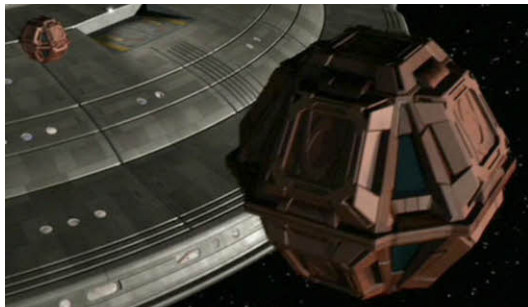

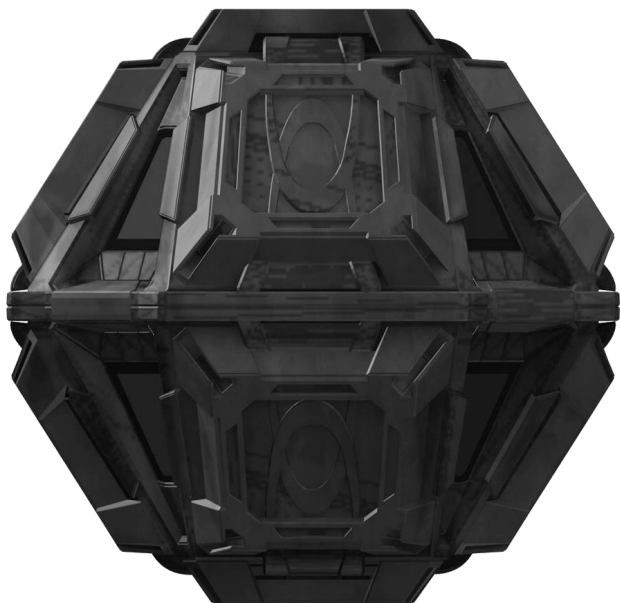

CELL SHIP (LONG)



Class: Cell Ship (Long)
Type: Modular space vessel
First Encountered: 2152
Production Base: Unknown, Sector 3641
Length: 40 metres
Beam: 15.4 metres
Height: 7.93 metres

Mass: 1,000 metric tons
Crew: Unknown
Cruising Speed: Warp 5
Maximum Speed: Unknown
Armament: 1 Particle cannon

Known Ships
Names unknown

CLASS INFORMATION:

Larger and more robust than its cousin, the short *cell ship*, the long *cell ship* was less common. Very little is known about these larger versions as one has never been examined by humans at close-hand. However, like the shorter type, the long *cell ship* was equipped with high-yield particle beam weapons, a tractor beam and a cloaking device. They were typically used in offensive and troop transport roles.

Long *cell ships* featured docking ports fore and aft and on both flanks, allowing them to connect together or assemble into larger structures in a similar fashion to short *cell ships*.

The *Enterprise NX-01* encountered these vessels on several occasions during the course of its involvement in the Temporal Cold War from 2151-54 .



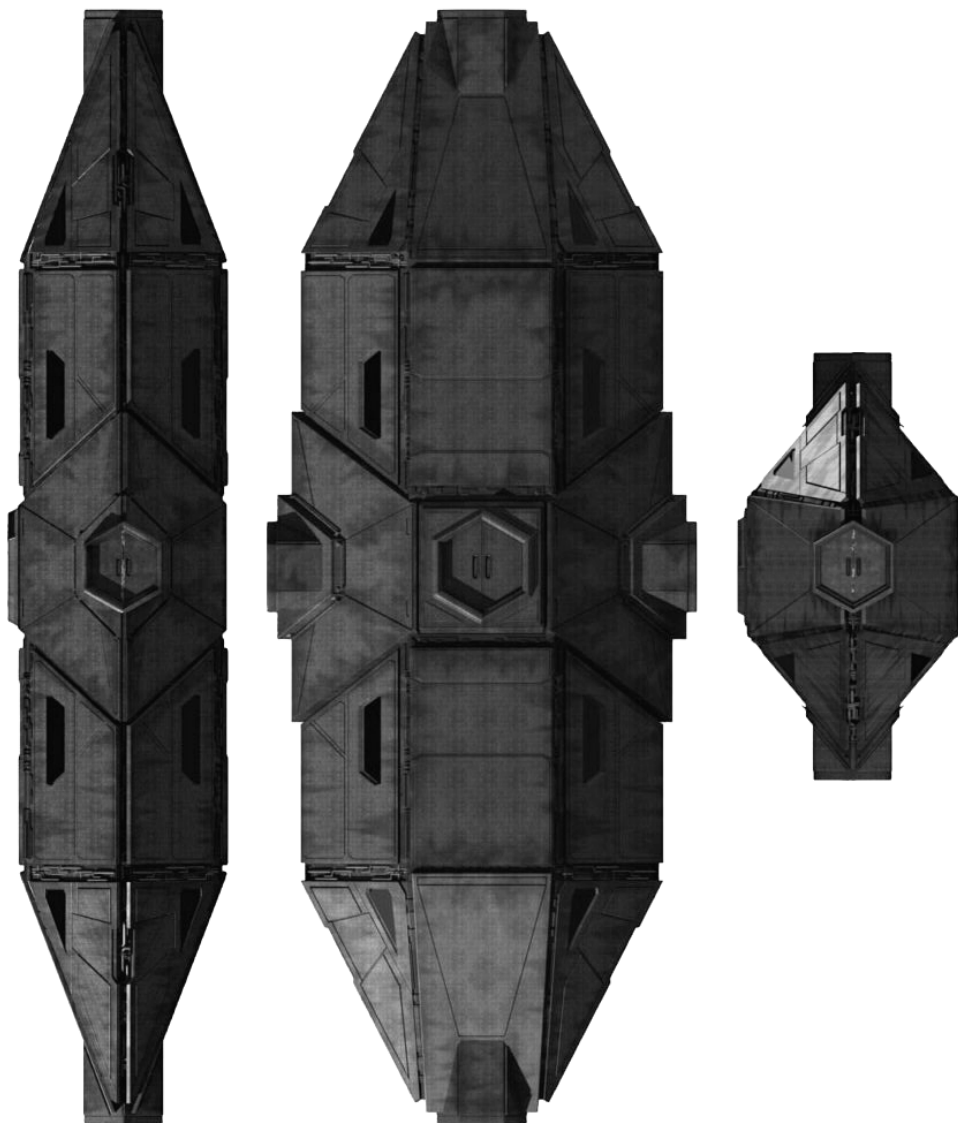

SALVAGE SHIP

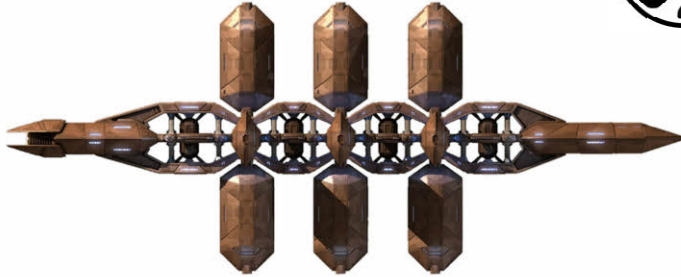

Class: Salvage Ship

Type: Freighter

First Encountered: 2152

Production Base: Unknown,
Sector 3641

Length: 240 metres

Beam: 96 metres

Height: 96 metres

Mass: 18,000 metric tons

Crew: Unknown

Cruising Speed: Warp 5

Maximum Speed: Unknown

Armament: 2 Particle cannons

Known Ships

Names unknown

CLASS INFORMATION:

The Suliban salvage ship was a modular freighter operated by the Suliban Cabal. The design of the ship consisted of a long central spine with up to twelve long *cell ships* docked around it. The core section was presumed to contain the ship's command and propulsion sections.

The salvage ship was minimally armed, with at least one forward and aft particle cannon. It was also equipped with a transporter system, tractor beam and cloaking device, and was capable of exceeding warp factor five.

In late 2152, the *Enterprise* NX-01 encountered one of these ships while trying to salvage a 31st century time pod. It was destroyed, along with the *cell ships* escorting it, by a group of Tholian starships also attempting to claim the craft.



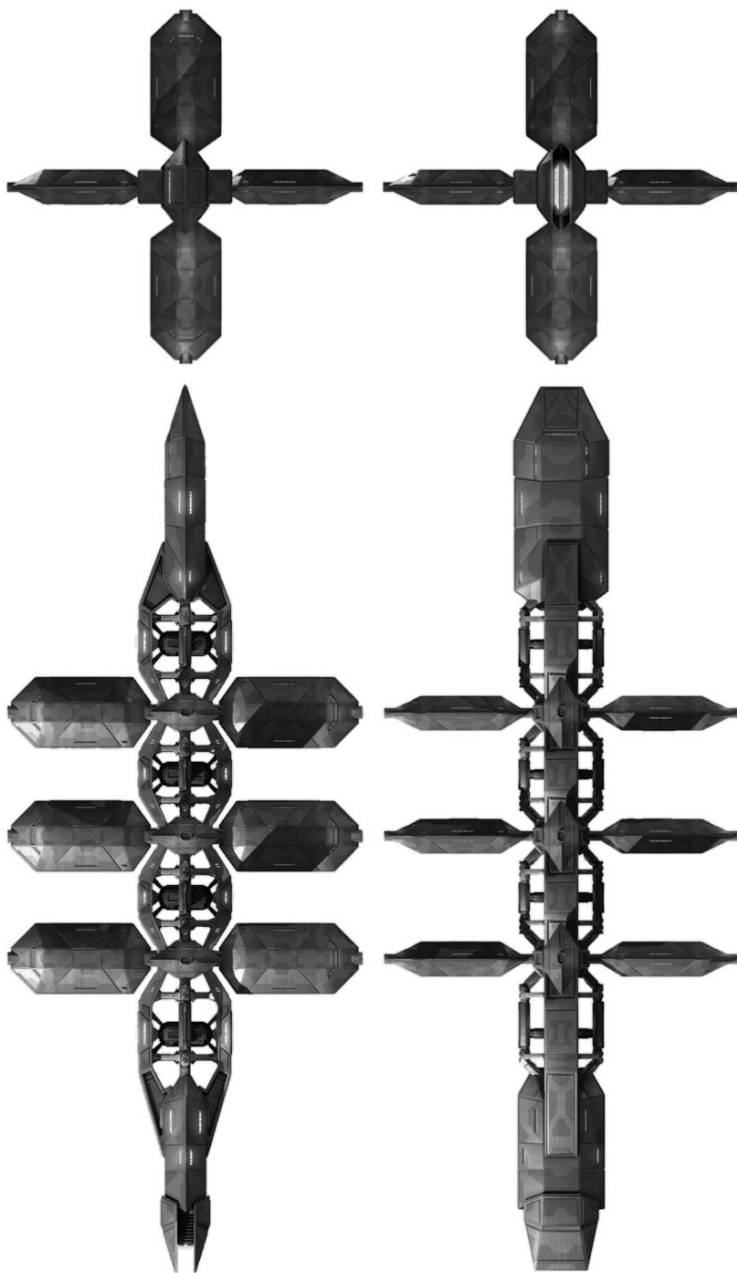

STEALTH CRUISER



Class: Stealth Cruiser

Type: Cruiser

First Encountered: 2152

Production Base: Unknown,
Sector 3641

Length: 106 metres

Beam: 50.6 metres

Height: 16.4 metres

Mass: Unknown

Crew: 20

Cruising Speed: Unknown

Maximum Speed: Unknown

Armament: 4 Particle cannons

Known Ships

Names unknown

CLASS INFORMATION:

The Suliban stealth cruiser was a sophisticated and comparatively large starship used by the Suliban Cabal that carried a cloaking device, rendering it undetectable by mid-22nd century Human technology. Its armament included four particle beam weapon banks. The standard crew complement was no more than twenty.

In March 2152, a Suliban stealth cruiser planted a small device on one of the *Enterprise* NX-01's shuttlepods that emitted a plasma stream, resulting in the destruction of the colony on Paraagan II.

The cruiser was later discovered by the *Enterprise* in a nearby binary star system using quantum beacons provided by Temporal Cold War agent Daniels. A boarding party successfully retrieved data from the ship confirming that the Suliban were responsible for the colony's destruction.



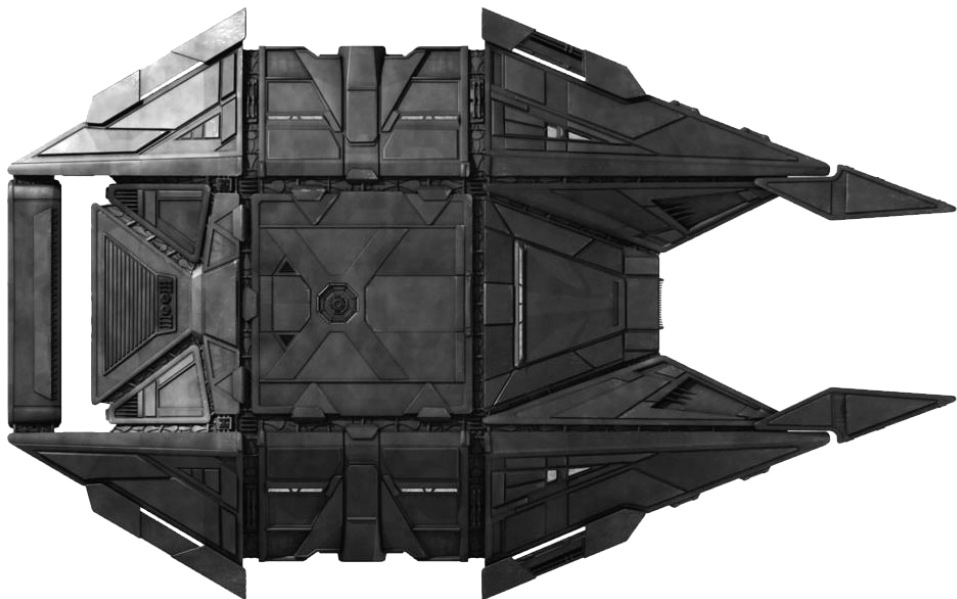



**XINDI
STARSHIPS**

XINDI-AQUATIC CRUISER



Class: Unknown

Type: Cruiser

First Encountered: 2154

Production Base: Unknown,
Delphic Expanse

Length: 1,800 metres

Beam: 1,574 metres

Height: 186 metres

Mass: Unknown

Crew: Unknown

Cruising Speed: Unknown

Maximum Speed: Unknown

Armament: Particle cannons

Known Ships

Names unknown

CLASS INFORMATION:

The flagship of the Xindi-Aquatic fleet, the Xindi-Aquatic cruiser was the largest and most advanced vessel used by any of the Xindi species. The cruiser featured a hydrodynamic, swept-wing hull with a large hangar bay on the ventral side of the ship that could be used to carry smaller starships. A large portion of the ship was filled with water, but it also had at least one small room where oxygen-breathing humanoids could come aboard and communicate with the Aquatic crew.

The Xindi-Aquatic cruiser was heavily-armed but had limited conventional propulsion systems. However, it could open a subspace vortex, enabling transwarp-like travel, reducing transit time from the Delphic Expanse to Earth to just ten hours.

One of these cruisers took part in the battle to stop the Xindi superweapon after it was commandeered by the Xindi-Reptilians. It was disabled during the battle by a spatial anomaly generated by a nearby Sphere.

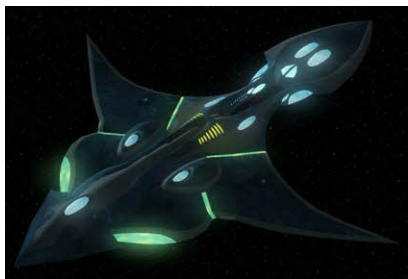

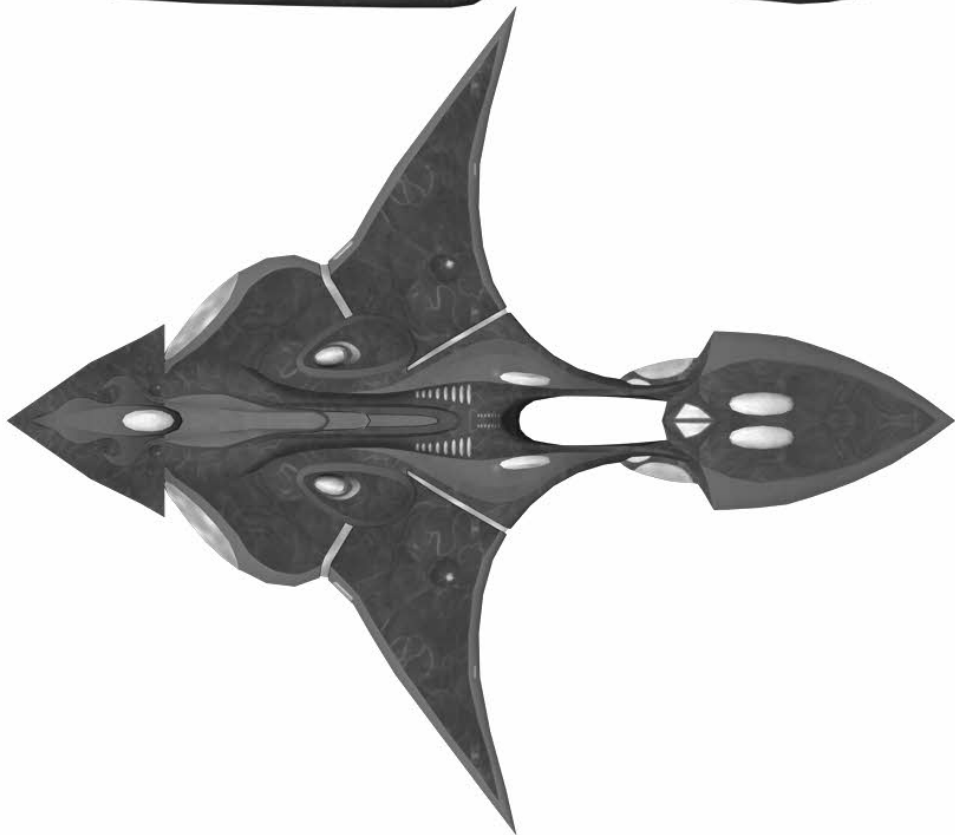

XINDI-INSECTOID WARSHIP



Class: Unknown

Type: Warship

First Encountered: 2154

Production Base: Unknown,
Delphic Expanse

Length: 120 metres

Beam: 86 metres

Height: 70 metres

Mass: 40,000 metric tonnes

Crew: 60

Cruising Speed: Warp 4

Maximum Speed: Warp 5

Armament: 4 Particle cannons,
3 torpedo launchers

Known Ships

Names unknown

CLASS INFORMATION:

The Xindi-Insectoid warship was used by the aggressive Xindi-Insectoids in the 2150s.

It consisted of a small central core containing the drive system and three wing-like sections extending forward, mounted equidistantly along the fore-aft axis. The ships were heavily armed and had a highly decentralized layout, with no central control room, reflecting the non-hierarchical nature of Insectoid culture. There was at least one room equipped with a viewscreen for communications. As with many other Xindi starships, the Insectoid vessel could use subspace vortices for travel.

In early 2154, the *Enterprise* NX-01 discovered the wreckage of a crashed Insectoid warship en route to Azati Prime. Insectoid ships participated in the attack on *Enterprise* at Azati Prime, as well as the later battles to stop the Xindi superweapon.



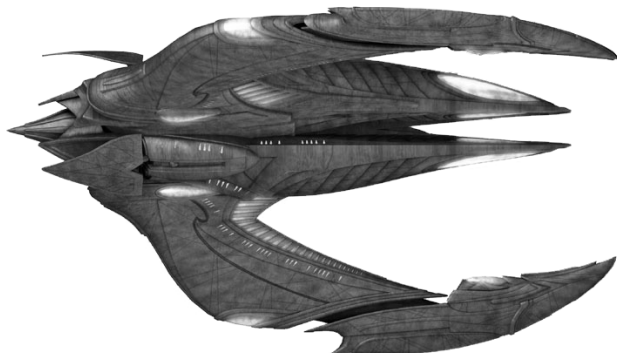
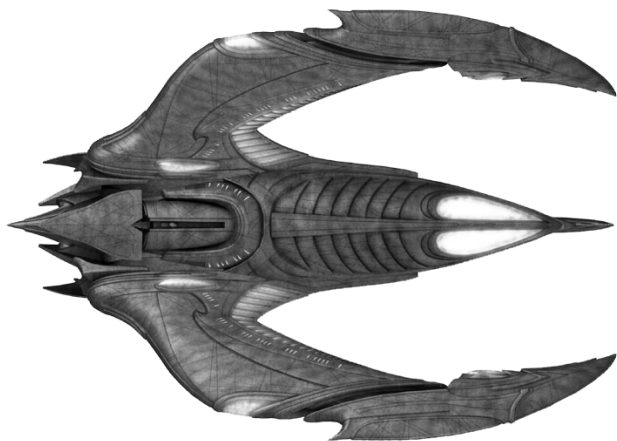

SPHERE BUILDER POD



Class: Unknown
Type: Trans-dimensional pod
First Encountered: 2153
Production Base: Unknown
Length: 5 metres
Beam: 1.6 metres
Height: 1.6 metres
Mass: Unknown

Crew: 1
Cruising Speed: N/A
Maximum Speed: N/A
Armament: None

Known Ships
Names unknown

CLASS INFORMATION:

The Sphere Builders were a race of aliens from a different dimensional plane to our own. They constructed a series of artificial spheres to create the Delphic Expanse, reconfiguring space to be more habitable for their own purposes.

In December 2153, the Sphere Builders sent a test subject, contained in a trans-dimensional pod, inside an intense spatial anomaly to determine whether the spheres were successfully modifying the Expanse to suit their needs. The pod was discovered by the crew of the *Enterprise* NX-01. After the individual was removed from the anomaly, he began to disintegrate due to his body's incompatibility with this universe. Before he died, he unsuccessfully attempted to destroy the *Enterprise*, as well as revealing the malevolent nature of the Sphere Builders and their alliance with the Xindi.



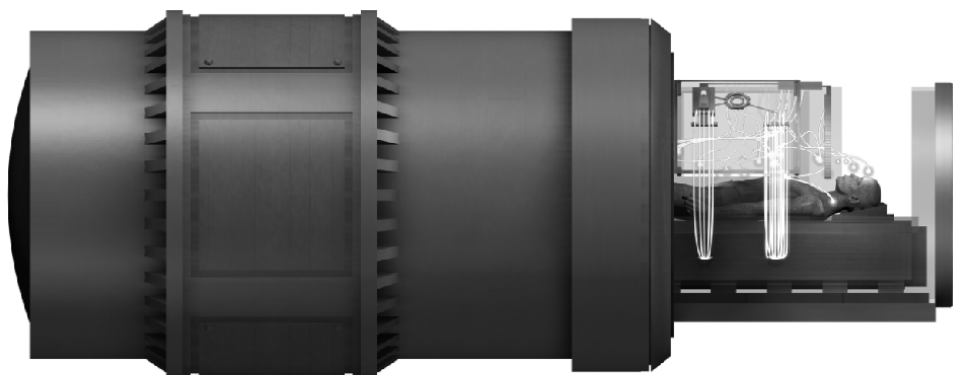

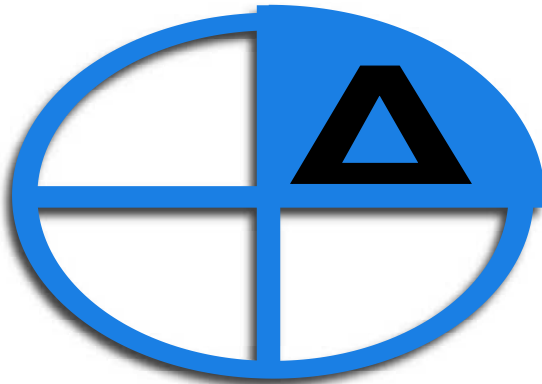

DELTA QUADRANT STARSHIPS

DEVORE WARSHIP



Class: Unknown
Type: Warship
First Encountered: 2375
Production Base: Devore Prime, Devore Imperium
Length: 800 metres
Beam: 492 metres
Height: 157 metres

Mass: Unknown
Crew: Unknown
Cruising Speed: Unknown
Maximum Speed: Unknown
Armament: Unknown

Known Ships
Names unknown

CLASS INFORMATION:

The Devore warship is a type of large starship operated by the xenophobic Devore Imperium in the 24th century. Two of these vessels substantially outgun a Federation *Intrepid*-class starship. Devore warships are equipped with refractive shielding, which renders them difficult to detect on sensors.

Devore warships work in conjunction with a series of automated detection arrays that regularly scan for vessels within their territory. The Devore routinely dispatch two warships to inspect alien vessels, but will commit a dozen ships to a single location if necessary to ensure superior firepower to any potential threat.

The *U.S.S. Voyager* NCC-74656 was regularly stopped for inspection by pairs of warships while passing through the Devore Imperium on its journey back to the Alpha Quadrant in 2375.



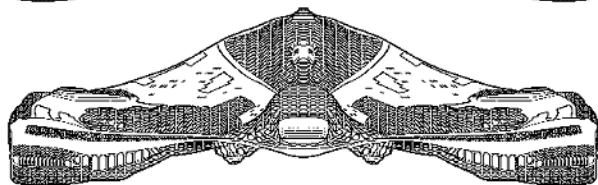
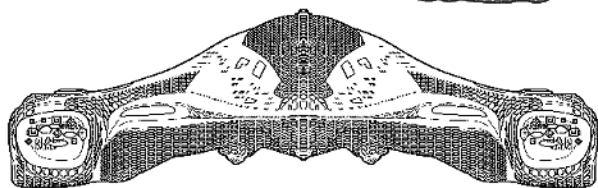
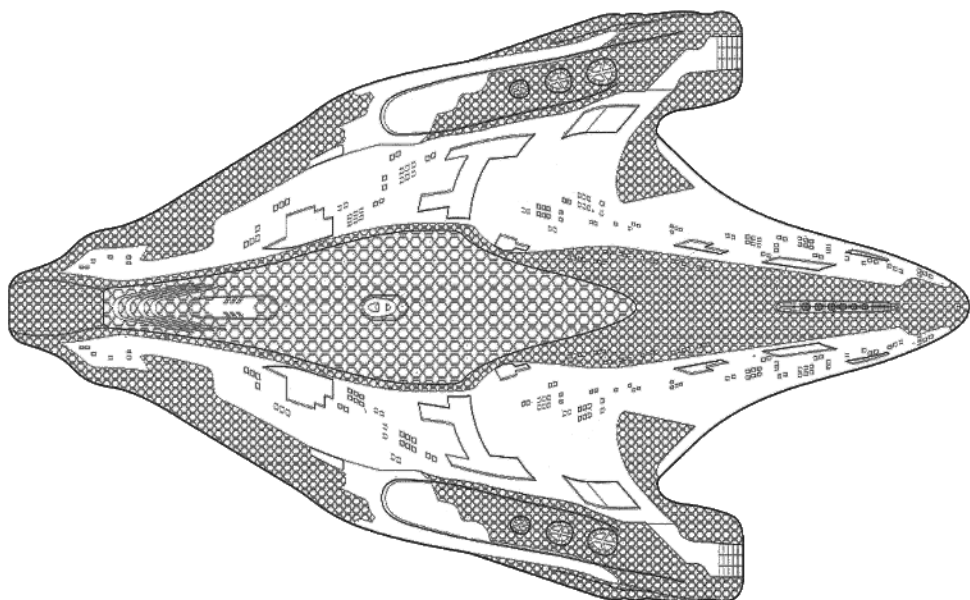
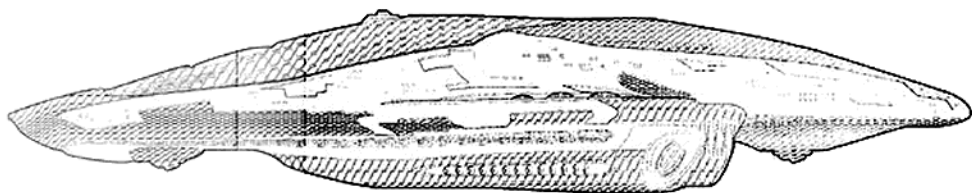

HIROGEN HUNTER SHIP



Class: Hunter

Type: Cruiser

First Encountered: 2374

Production Base: Unknown,
Delta Quadrant

Length: 150 metres

Beam: 88.9 metres

Height: 39.3 metres

Mass: 56,900 metric tons

Crew: 2-7

Cruising Speed: Unknown

Maximum Speed: Warp 8

Armament: 6 Weapons arrays,
2 torpedo launchers

Known Ships

Names unknown

CLASS INFORMATION:

Hirogen hunter ships are optimised for the search, acquisition, targeting, pursuit and capture of prey of all types. Most Hirogen vessels travel alone with a crew of just two. Occasionally they are encountered in groups or packs however.

New technology is typically mounted to the exterior of the Hunter ship's hull rather than being integrated internally. Hirogen vessels feature torpedo launchers, shield emitters and sensors. They are also equipped with subnucleonic beams which can perform rapid scans of other vessels and disrupt propulsion and navigational sensors. Once disabled, the Hirogen then use tractor beams to capture their prey.

Hirogen ships have monotonium armor plating which offers extra protection and can scatter targeting beams. They are also able to mask their engine emissions by operating in a stealth mode when they wish to track another vessel undetected.

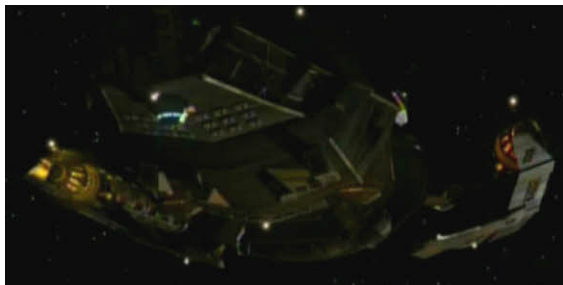

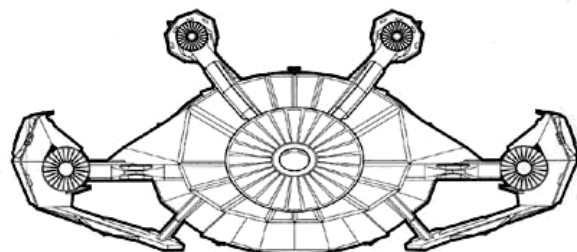
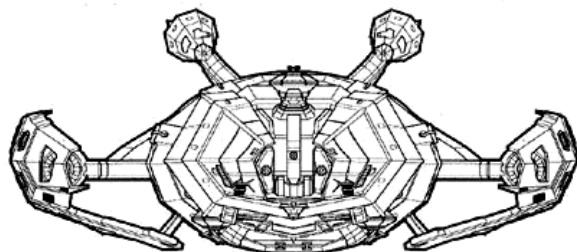
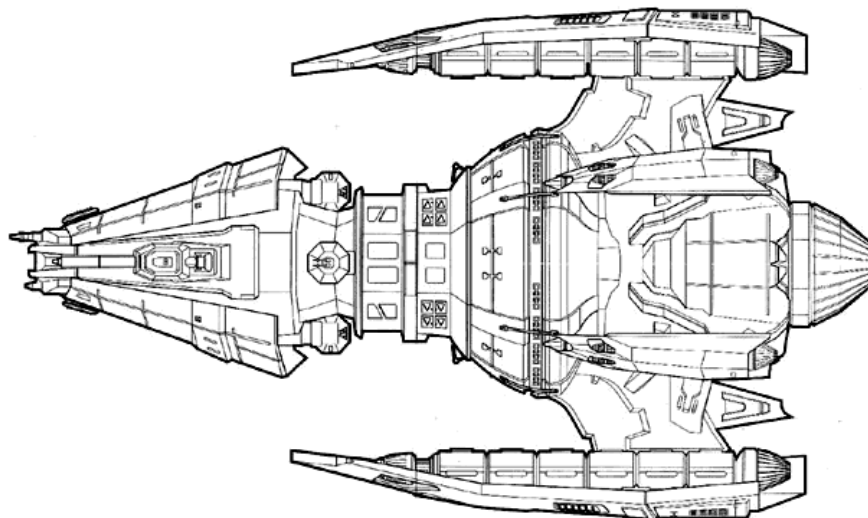
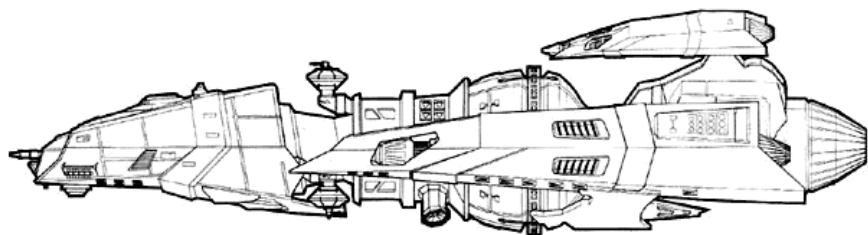

HIROGEN VENATIC CLASS



Class: Venatic
Type: Battleship
First Encountered: 2377
Production Base: Unknown, Delta Quadrant
Length: 600 metres
Beam: 247 metres
Height: 113 metres

Mass: Unknown
Crew: 15-20
Cruising Speed: Unknown
Maximum Speed: Unknown
Armament: Unknown

Known Ships
(Names unknown)

CLASS INFORMATION:

The *Venatic*-class was a type of hunting starship used by the Hirogen during the 2370s. This class of vessel, manned by a crew of fifteen or twenty, was considerably larger than both the Hirogen cruiser and the Federation *Intrepid*-class.

Like the smaller Hunter vessels, the *Venatic*-class was equipped with a subnucleonic beam, monotonium armour plating, and its engines - featuring a quad nacelle design - could be operated in stealth mode. However, the *Venatic*-class had a major flaw in its sensor system: the engines created a blind spot aft of the ship, where smaller vessels could hide and avoid sensor detection by the hunters.

In 2377, the *U.S.S. Voyager* NCC-74656 exploited the sensor weakness to secretly follow two *Venatic*-class ships. These vessels pursued a third ship crewed by Hirogen prey holograms into a nebula and were later disabled by *Voyager*.



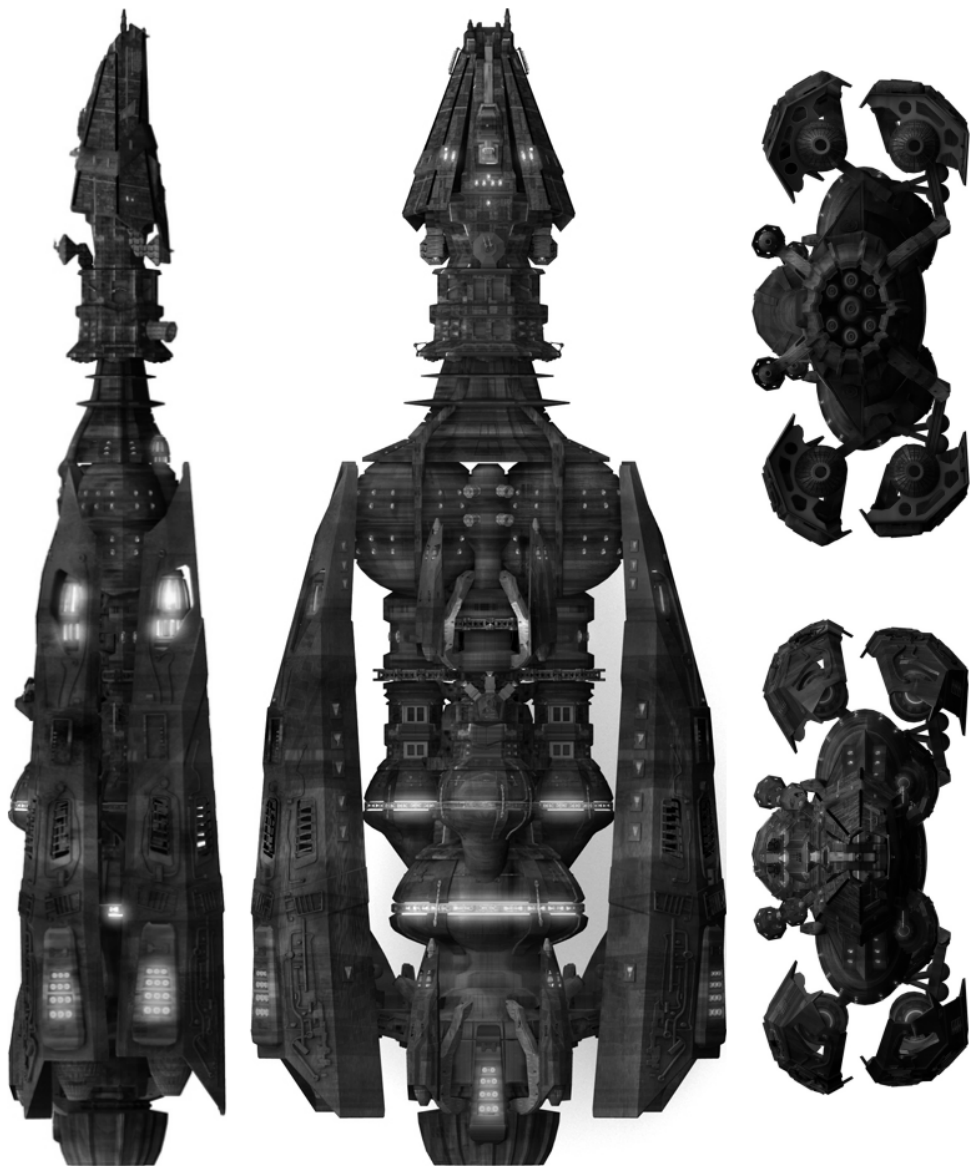

KAZON CARRIER

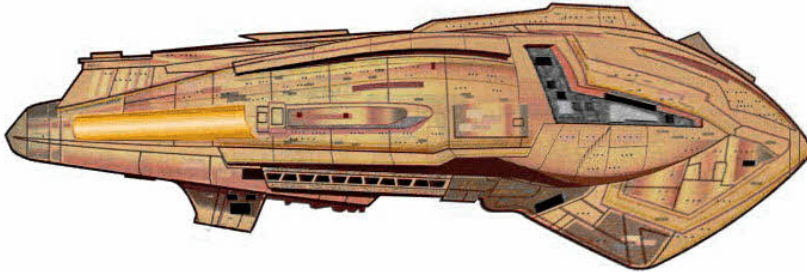

Class: Predator

Type: Carrier/Mothership

First Encountered: 2371

Production Base: Unknown,
Delta Quadrant

Length: 1,920 metres

Beam: 350 metres

Height: 590 metres

Mass: 60,000,000 metric tons

Crew: 1,500

Cruising Speed: Warp 5

Maximum Speed: Warp 7.2

Armament: 60 Phaser banks, 2
photonic charge launchers

Known Ships

Names unknown

CLASS INFORMATION:

The Kazon carrier vessel or mothership was originally a Trabe design, and seized by the Kazon Collective when they rose up against their Trabe oppressors in 2346. The Kazon use this class of vessel as a massive warship, but despite being heavily armed it is much more sluggish in battle at lower speeds than at warp, and can be easily outmanoeuvred by more agile craft.

Only two sects were known to possess this class during the 2370s: the Kazon-Ogla and the Kazon-Nistrim. Although the Kazon had seized a large majority of the Trabe fleet, a small number of these ships remained as part of the Trabe convoy.

The *U.S.S. Voyager* first encountered the Kazon carrier in 2371 while protecting the Caretaker's array. This Ogla carrier was destroyed when it crashed into the array after being rammed by the Maquis raider, *Val Jean*.



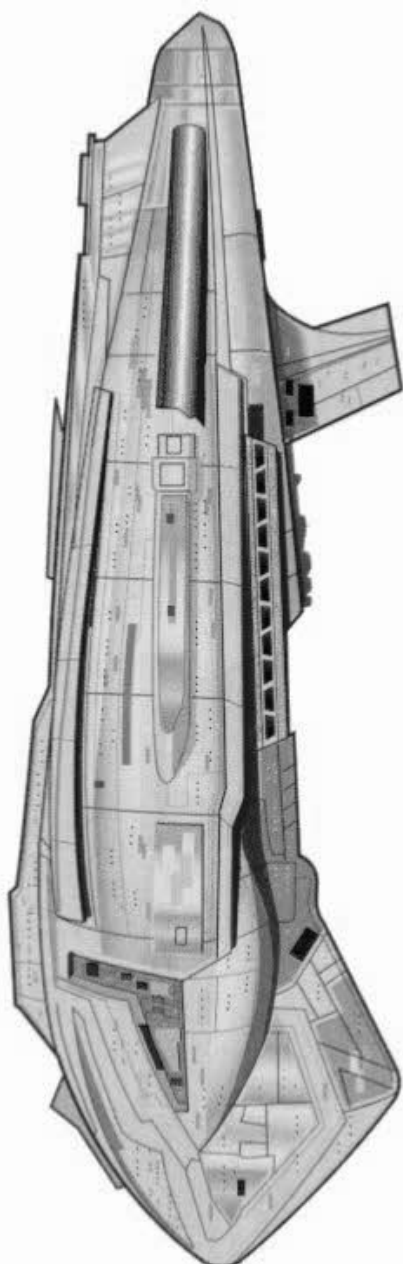
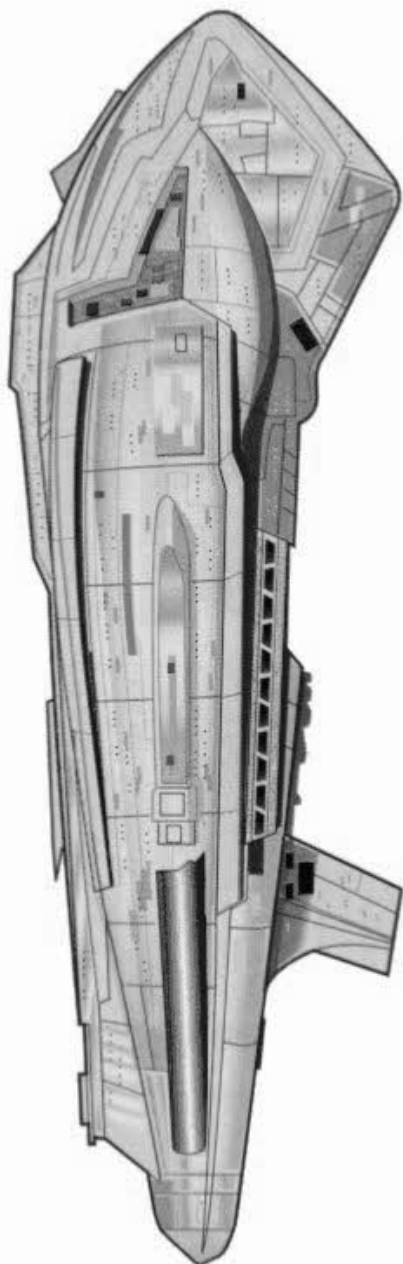

KAZON RAIDER

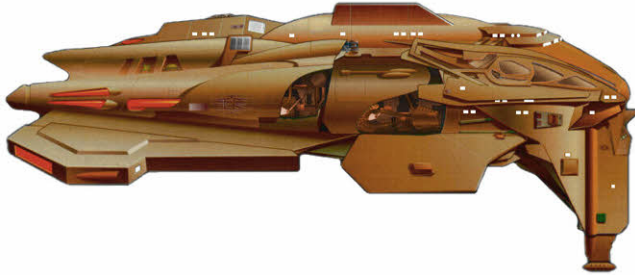

Class: Raider
Type: Warship
First Encountered: 2371
Production Base: Unknown, Delta Quadrant
Length: 165 metres
Beam: 40 metres
Height: 70 metres

Mass: 100,000 metric tons
Crew: 225
Cruising Speed: Warp 5
Maximum Speed: Warp 8
Armament: 4 Phaser banks, 2 plasma cannons, 2 photonic charge launchers

Known Ships
Names unknown

CLASS INFORMATION:

The Kazon raider is a medium-sized starship originally used by the Trabe. Like other Kazon vessels the raider is technologically limited, and easily outmatched by a Federation *Intrepid*-class starship.

Armaments include two forward plasma cannons and photonic charges with variable yields. The Kazon raider has a shuttlebay to carry a compliment of smaller fighter vessels of a similar design to the raider. Some raiders are also equipped with masking circuitry designed to confuse enemy sensors, though this is nowhere near as effective as a cloaking device.

The exact specifications and state of each raider varies due to inconsistent maintenance and systems upgrades by the scavenging Kazon.



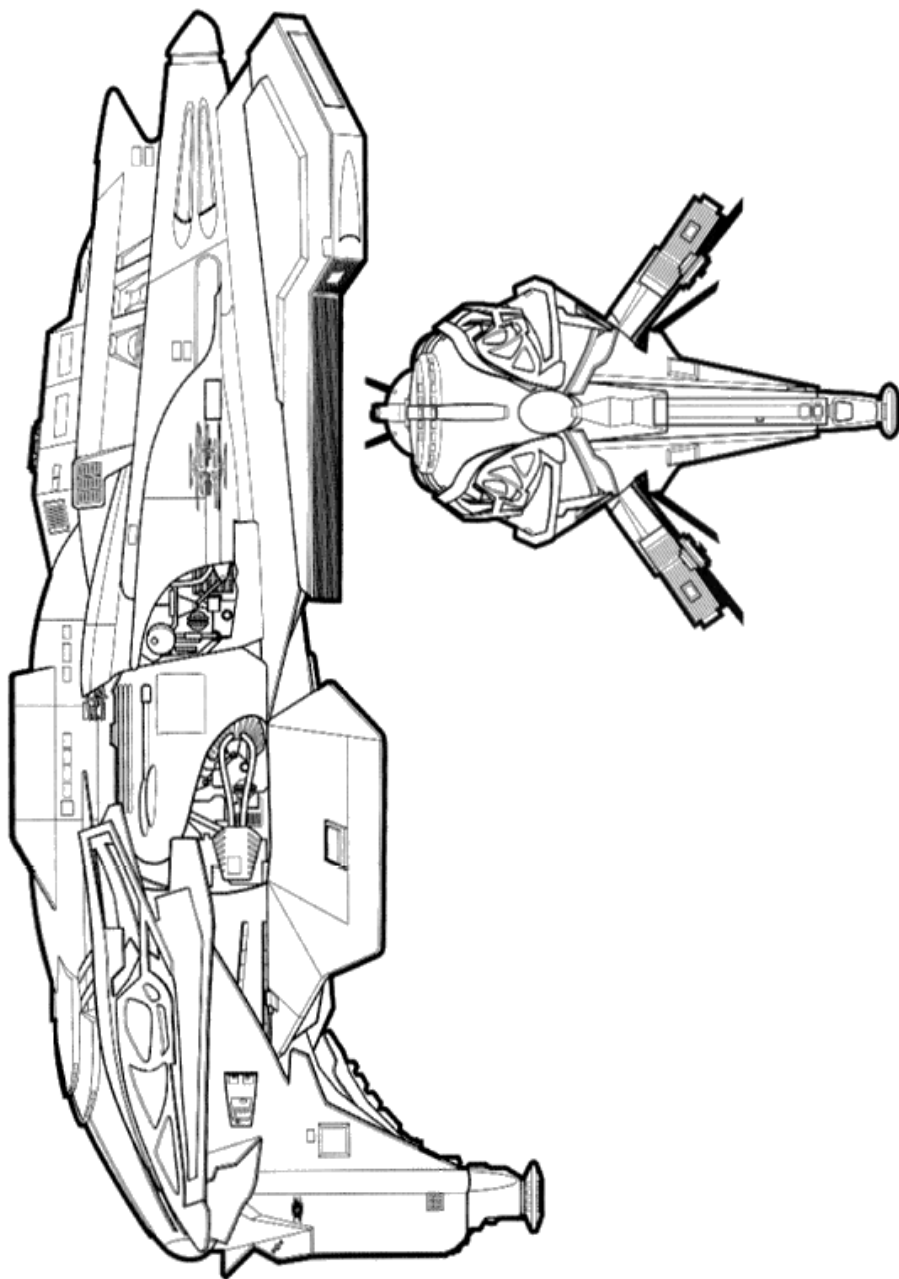

KRENIM WARSHIP



Class: Unknown

Type: Warship

First Encountered: 2374

Production Base: Unknown,
Krenim Imperium

Length: 500 metres

Beam: 264 metres

Height: 77 metres

Mass: Unknown

Crew: Unknown

Cruising Speed: Unknown

Maximum Speed: Warp 6

Armament: Chroniton torpedo
launchers

Known Ships

Names unknown

CLASS INFORMATION:

The Krenim warship was utilized by the Krenim in the Delta Quadrant during the 24th century. The Krenim are one of the few species in the galaxy besides the Federation which use temporal technology.

Krenim warships were not particularly heavily armed or protected, but were larger and more powerful than an *Intrepid*-class starship, due in part to their complement of chroniton torpedoes. When fired these torpedoes enter into a state of temporal flux, and this phase variance enables them to penetrate enemy shields almost unhindered.

The *U.S.S. Voyager* was eventually able to establish a form of temporal shielding, protecting it from both the chroniton torpedoes and the incursions of the Krenim's temporal weapon ship.



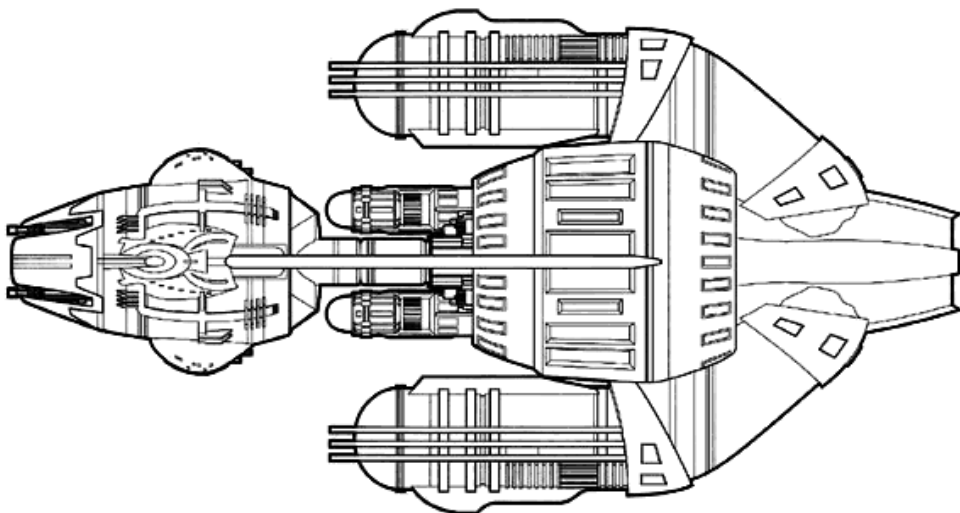
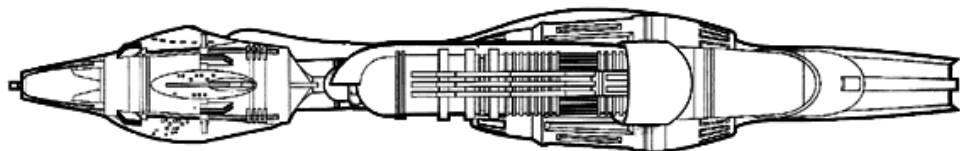

MALON EXPORT VESSEL

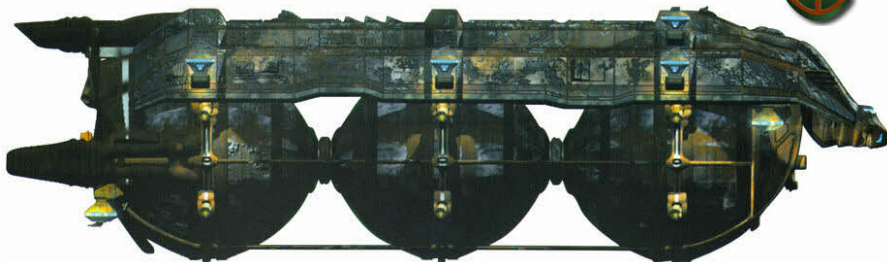

Class: 11th Gradient

Type: Freighter

First Encountered: 2375

Production Base: Malon Prime,
Malon Sanctity

Length: 317.3 metres

Beam: 105.8 metres

Height: 92.6 metres

Mass: 1,165,000 metric tons

Crew: 9

Cruising Speed: Unknown

Maximum Speed: Warp 9

Armament: 12 Spatial charge
launchers

Known Ships

Names unknown

CLASS INFORMATION:

A Malon export vessel is a type of large freighter designed for long-range haulage and dumping of contaminated antimatter waste produced by the Malon Sanctity. Due to the harmful theta radiation emitted by the cargo, Malon export vessels are heavily shielded, also making them impervious to many conventional weapons.

Waste export vessels are commanded by a controller, and crewmembers who work near the hazardous waste regions of the theta storage tanks are known as core laborers. The freighters are armed with spatial charge launchers. They are also equipped with escape pods for use in emergencies and can eject damaged storage tanks into space if they threaten the ship.

11th Gradient-class freighters can transport over ninety million isotons of contaminated antimatter. Larger classes can transport as much as four trillion isotons.



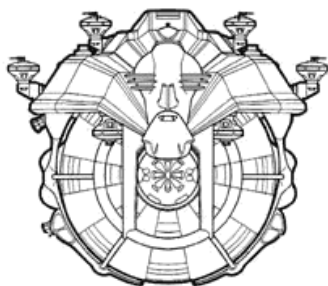
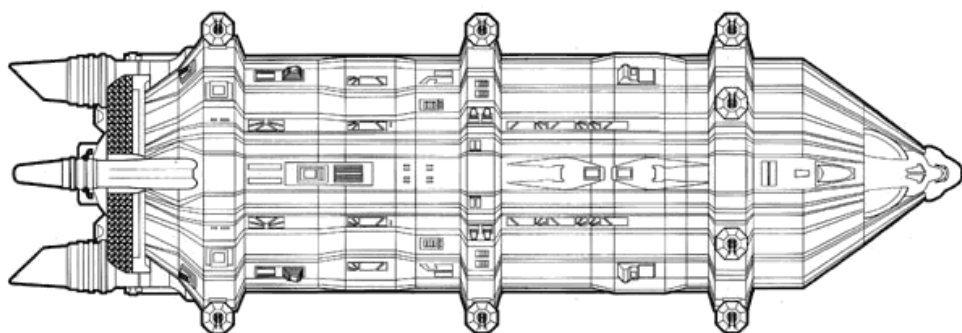
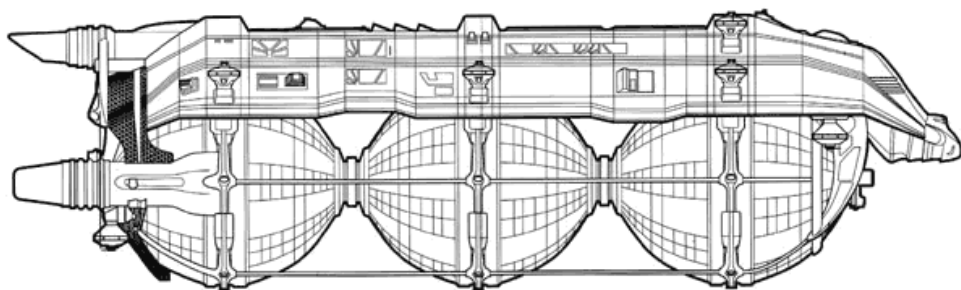

SPECIES 8472 BIOSHIP



Class: Bioship

Type: Organic vessel

First Encountered: 2373

Production Base: Unknown,

Fluidic Space

Length: Variable

Beam: Variable

Height: Variable

Mass: Variable

Crew: 1

Cruising Speed: Unknown

Maximum Speed: Unknown

Armament: 1 Bio-kinetic energy
weapon

Known Ships

Ay Hort ☿

Cuh Thug Ah ☿†

† *Lost or destroyed*

☿ *Non-canon*

CLASS INFORMATION:

The Species 8472 bioship is an organic vessel with a similar genetic makeup to members of Species 8472 itself. Bioships are piloted by a single individual, and are extremely powerful. A single ship can easily destroy a Borg cube, while a group of eight bioships can focus their energy weapons through a ninth vessel to produce a beam powerful enough to destroy a planet.

Species 8472 bioships are impervious to conventional weapons, and the organic material of the bioship is able to quickly heal itself after an attack. Bioships appear to be powered by antimatter particles, and can open quantum singularities to traverse between fluidic space and our galaxy. Their surface can reflect deep sensor scans and transporter locks. Bioships can also change shape depending on their operational mode. The crew of the *U.S.S. Voyager* developed a defence against the ships in the form of modified Borg nanoprobes.



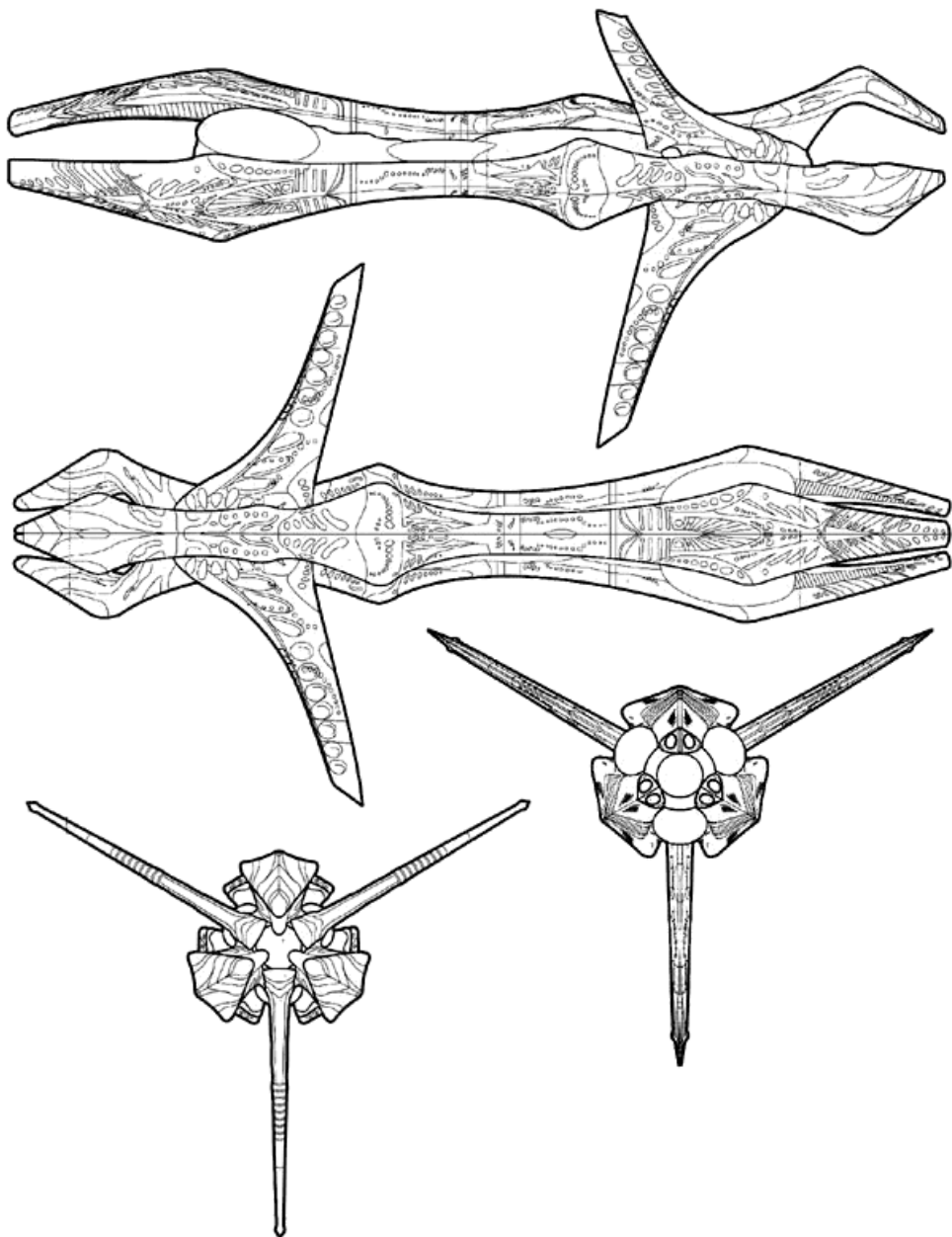

VIDIIAN CRUISER



Class: Unknown

Type: Cruiser

First Encountered: 2371

Production Base: Vidiia Prime,
Vidiiian Sodaloty

Length: 500 metres

Beam: 458 metres

Height: 95 metres

Mass: Unknown

Crew: 350

Cruising Speed: Unknown

Maximum Speed: Unknown

Armament: Hypothermic
charges

Known Ships

Names unknown

CLASS INFORMATION:

The Vidiiian cruiser was a large and heavily armed starship used by the Vidiiians in 2371 and 2372. This class of vessel operated with a crew of well over 300, and was armed with hypothermic charges. As the Vidiiians did not have transporter technology, the cruiser was equipped with extendable grapplers and cutters to board enemy vessels.

In 2372, the *U.S.S. Voyager* NCC-74656 was attacked by a Vidiiian cruiser while trapped in a plasma drift. At the time, a subspace divergence field had created a duplicate of *Voyager*, which was unseen to the Vidiiians. The Vidiiians attacked one of the two ships and destroyed its weapons array, before manoeuvring into grappling range and boring an access route through *Voyager's* hull. *Voyager* was then boarded by over 347 Vidiiians. Captain Kathryn Janeway auto-destructed *Voyager* to destroy the Vidiiian ship, allowing the other *Voyager* to escape unharmed.



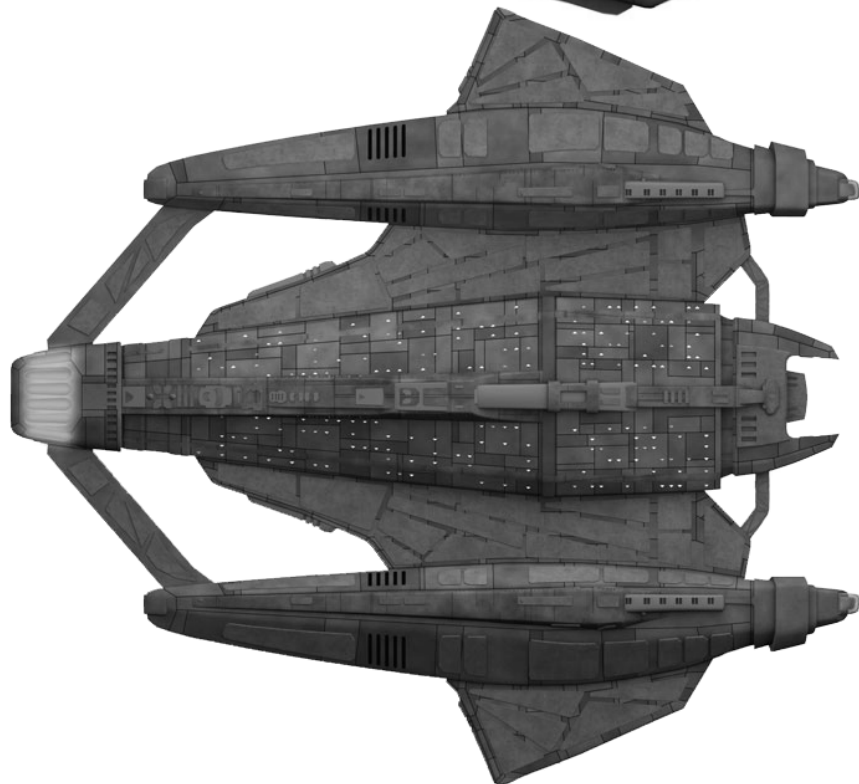

VIDIIAN INTERCEPTOR

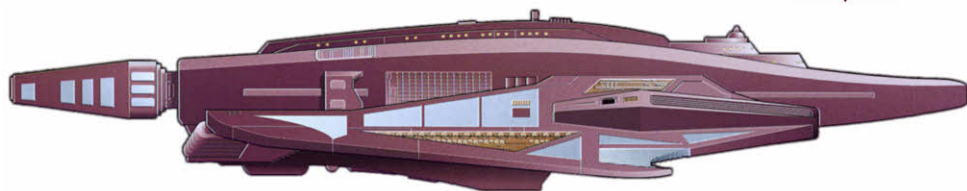

Class: Interceptor

Type: Warship

First Encountered: 2372

Production Base: Vidiia Prime, Vidiian Sodaloty

Length: 143.7 metres

Beam: 151.4 metres

Height: 26.7 metres

Mass: Unknown

Crew: Unknown

Cruising Speed: Unknown

Maximum Speed: Unknown

Armament: Hypothermic charges

Known Ships

Names unknown

CLASS INFORMATION:

The Vidiian interceptor was a type of relatively small but powerful warship utilized by the Vidiians during the 2370s. The interceptor was favoured for agility and manoeuvrability in battle, and suited for hit and fade attacks.

The Vidiian interceptor had a formidable arsenal and was well shielded for a vessel its size. In common with its larger counterpart, the Vidiian cruiser, the interceptor was armed with hypothermic charges - powerful directed energy weapons. Also like the Vidiian cruiser, the interceptor featured distinctive manta ray-shaped 'wings' which housed the warp nacelles, and a cone-shaped aft propulsion unit. The main navigational deflector and long-range sensor array were situated on the ventral hull of the vessel.

Sulan commanded an interceptor prior to his promotion to Chief Surgeon of the Vidiian Sodaloty,



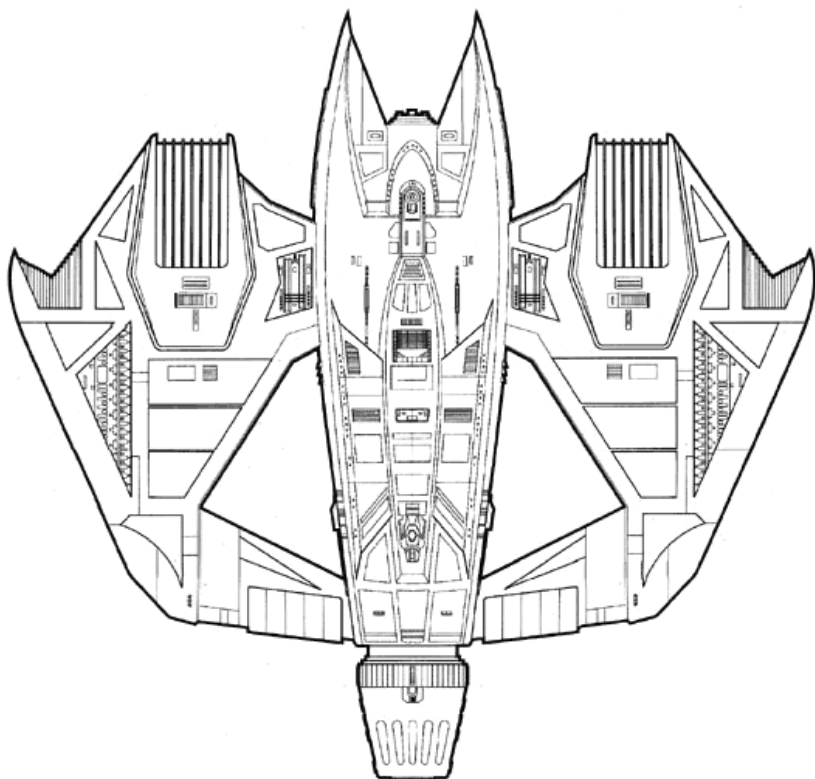
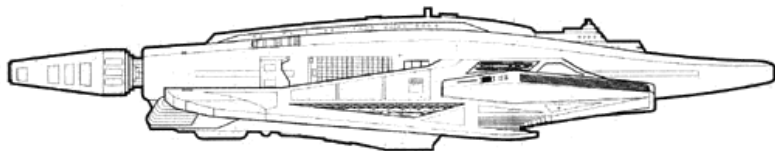

VOTH CITY SHIP

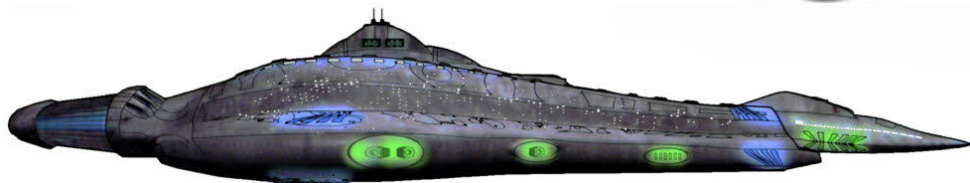

Class: Unknown
Type: City Ship
First Encountered: 2373
Production Base: Unknown
Length: 9,800 metres
Beam: 5,123 metres
Height: 1,840 metres
Mass: Unknown

Crew: Unknown
Cruising Speed: Unknown
Maximum Speed: Unknown
(Transwarp)
Armament: Unknown

Known Ships
(Name Unknown)

CLASS INFORMATION:

Essentially a mobile planet, the Voth city ship is a massive transwarp-capable starship that serves as the centre of the Voth civilization. It is one of the largest known vessels in the galaxy, over three times the length of a Borg cube.

This technologically advanced ship is equipped with high resolution scanners with a range of over ninety light years. The Voth also possess spatial displacement capabilities – a form of cloaking technology that can move their starships or even individuals out of phase.

In 2373 the Voth city ship located and captured the *U.S.S. Voyager* NCC-74656 - beaming the Federation starship into a vast chamber inside the vessel. A dampening field within the city ship made *Voyager's* main power inoperative, and rendered tricorders, communicators, and phasers useless.

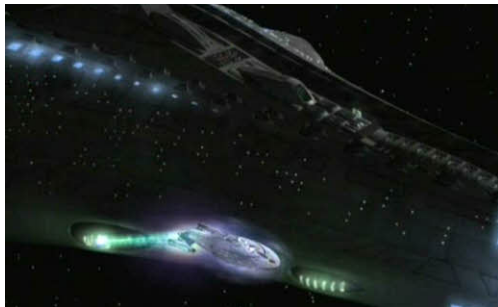

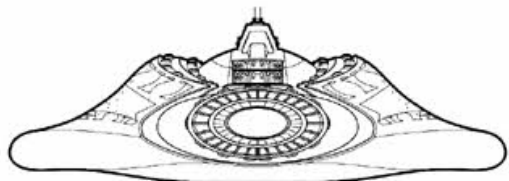
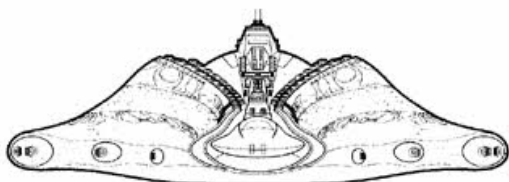
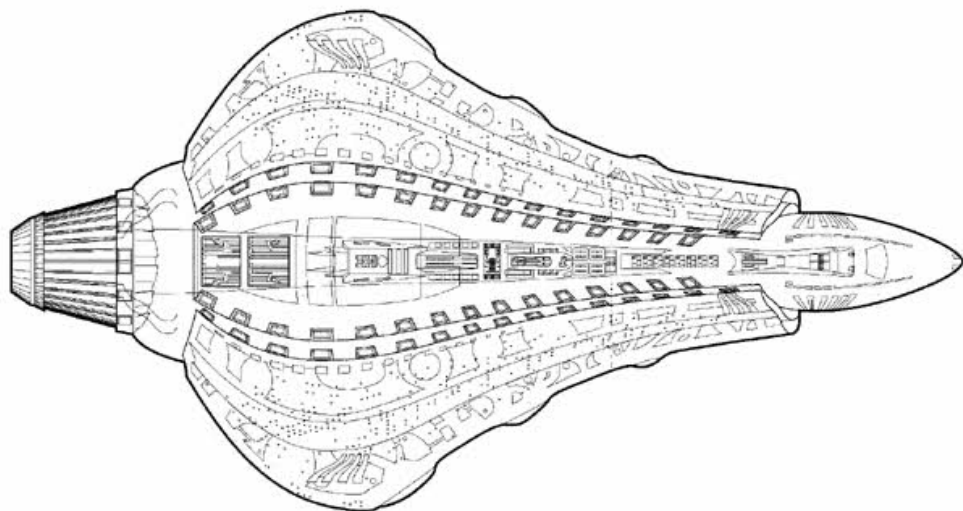
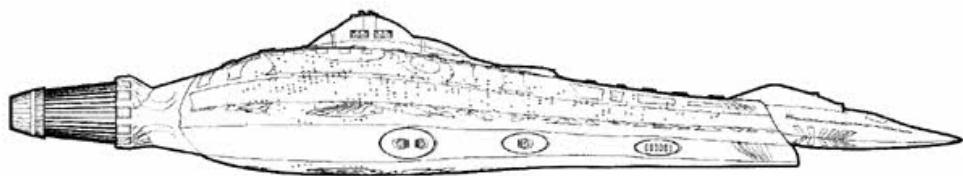

VOTH RESEARCH VESSEL



Class: Unknown
Type: Research Vessel
First Encountered: 2373
Production Base: Voth City Ship, Delta Quadrant
Length: 130 metres
Beam: 74.4 metres
Height: 32.1 metres

Mass: Unknown
Crew: 1-10
Cruising Speed: Unknown
Maximum Speed: Unknown (Transwarp)
Armament: Unknown

Known Ships
Names unknown

CLASS INFORMATION:

The Voth research vessel is a small yet highly advanced science ship. Like the rest of the Voth civilisation it is based in the vast Voth City Ship in the Delta Quadrant.

The Voth research vessel possesses transwarp capabilities, enabling speeds in excess of 50,000 times the speed of light. It also features highly advanced sensors able to scan from a distance of over ninety light years with significant accuracy, even down to individual lifeform readings. Additionally the research vessel has a transphasic cloaking device, and could be piloted by a single individual.

Voth scientist Forra Gegan utilised a research vessel as part of his studies regarding the Distant Origin Theory, which stated that the Voth had evolved on Earth. This was later proven by the crew of the *U.S.S. Voyager*, who traced the species' DNA back to an ancestor that lived among the dinosaurs millions of years ago.



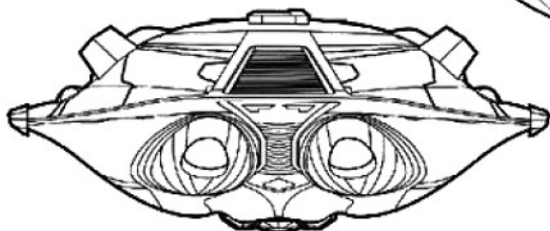
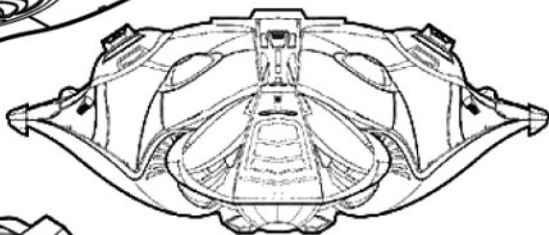
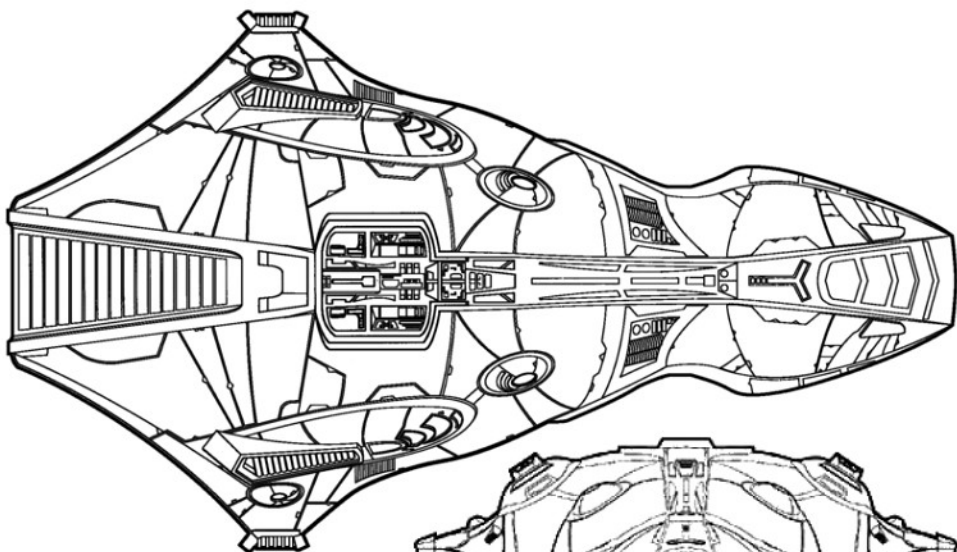
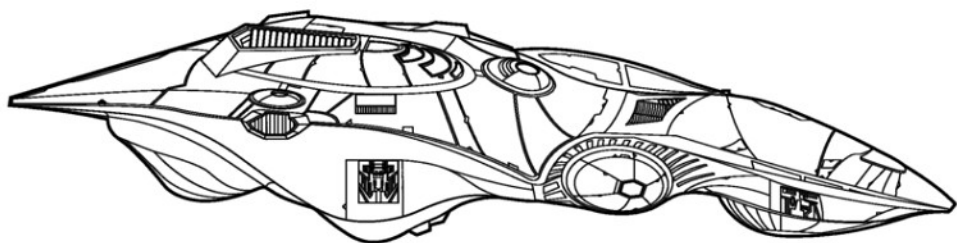



**EARTH &
FEDERATION
AUXILIARY
VESSELS**

AEROSHUTTLE



Class: Aeroshuttle/AeroWing
Type: Atmospheric Operations Craft
Commissioned: 2370
Production Base: Utopia Planitia Fleet Yards, Mars
Length: 24.8 metres
Beam: 29.6 metres

Height: 4.1 metres
Mass: 222.5 metric tons
Crew: 1-5
Cruising Speed: Warp 3
Maximum Speed: Warp 5
Armament: 4 Type VI phaser arrays, 2 Mk 25 photon micro-torpedo launchers

NCC	Known Ships
74600	(Name unknown)
74656	(Name unknown)
74705	(Name unknown)

CLASS INFORMATION:

The *Aeroshuttle* (or *AeroWing*) is a large auxiliary craft optimised for atmospheric operations, and is mounted beneath the primary hull of *Intrepid*-class starships.

The *Aeroshuttle* shares many systems with the similar-sized *Danube*-class runabout, from which it was derived. The streamlined hull and large reinforced wings of the *Aeroshuttle* make it more efficient in atmospheric manoeuvres, and its hybrid microfusion and EM driven airflow coil engines give it a 450 percent increase in atmospheric flight and hover endurance over standard shuttlecraft. The craft is equipped with a variety of sensor arrays for planetary surveys or reconnaissance.

The success of the *Aeroshuttle* led to the design of the more advanced *Waverider* shuttlecraft currently deployed aboard *Nova*-class starships.



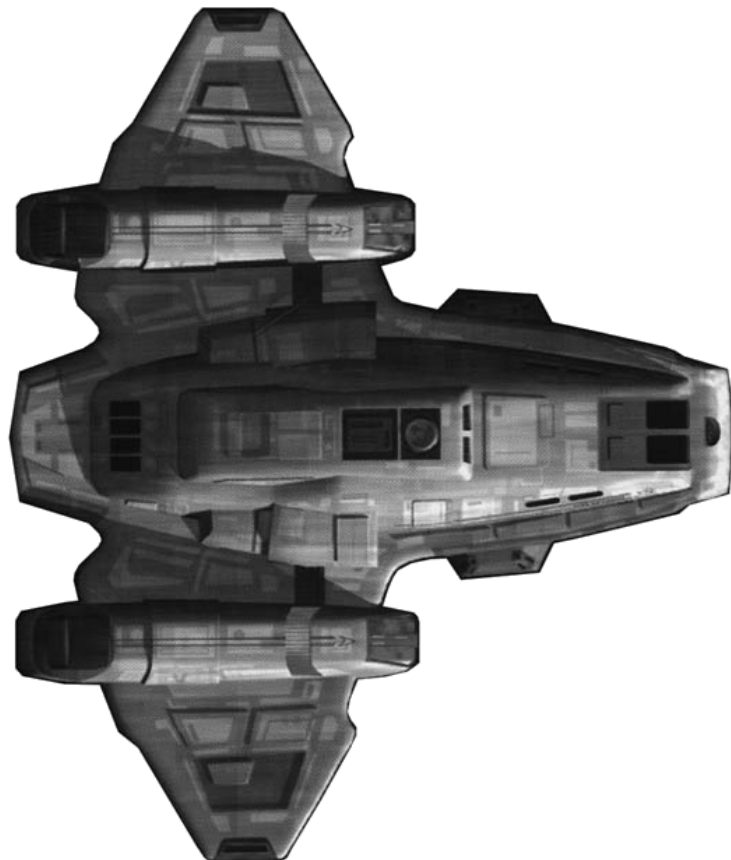

ARGO TRANSPORT SHUTTLE



Class: Argo
Type: Heavy Transport Shuttle
Commissioned: 2378
Production Base: San Francisco Fleet Yards, Earth
Length: 20 metres
Beam: 12 metres
Height: 5 metres

Mass: 30 metric tons
Crew: 2-5
Cruising Speed: Warp 3
Maximum Speed: Warp 4
Armament: 4 Type IV phaser emitters, 2 photon/quantum micro-torpedo launchers

NCC Known Ships
1701-E Argo

CLASS INFORMATION:

The *Argo* is a specialized shuttle carried on *Sovereign*-class starships, developed for ferrying cargo and vehicles when conditions preclude the use of transporters.

The ship is equipped with retractable wings that allow the craft to easily land on a variety of planetary surfaces. After departing from the shuttlebay the wings and dorsal fins deploy for atmospheric flight. The craft's warp nacelles are integrated into the body of the shuttle for increased protection.

The *Argo* can carry a small four-wheeled all-terrain vehicle (ATV) armed with an aft phaser cannon. The shuttle can be remotely controlled by a device on the vehicle.

Both the shuttle and the ATV were field-tested in 2378 by *U.S.S. Enterprise* NCC-1701-E personnel, Captain Jean-Luc Picard, Lt. Commander Data and Lt. Commander Worf, while investigating unique positronic signatures on Kolarus III.



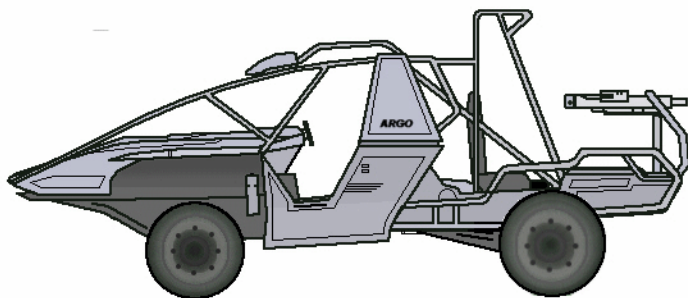
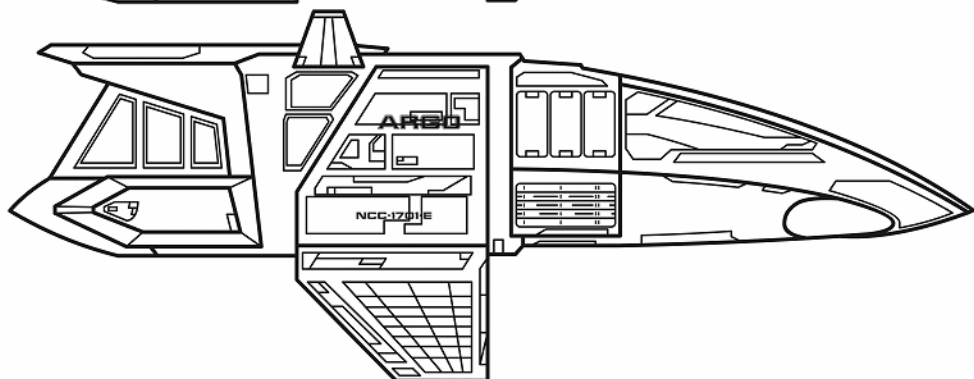
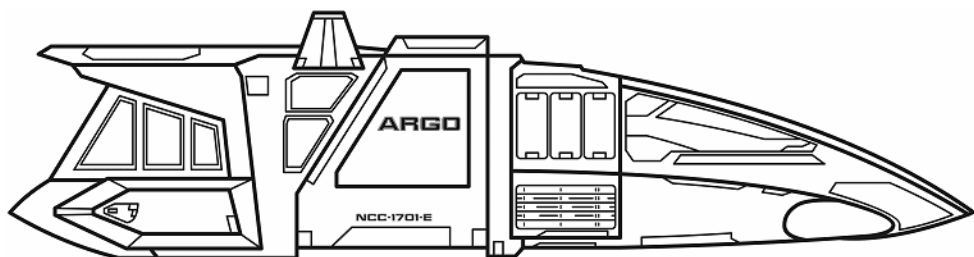

ATAI LONG RANGE SHUTTLE



Class: Atai

Type: Long-Range Shuttle

Commissioned: 2271

Production Base: 40 Eridani A
Starfleet Construction Yards

Length: 18.3 metres (48 metres
with warp sled)

Beam: 10.8 metres

Height: 4.7 metres

Mass: 35 metric tons

Crew: 2 (plus 20 passengers)

Cruising Speed: Warp 3

Maximum Speed: Warp 4

Armament: 4 Mini-phaser
emitters

NCC **Known Ships**

Atai ϕ

1701/5 Copernicus ϕ

1701/7 Galileo ϕ

1701/1 Halley ϕ

1701/3 Herschel ϕ

Laika

VS-5047-61192259584-5 Surak

ϕ Non-canon

CLASS INFORMATION:

The *Atai*-class long-range warp shuttle can be regarded as the predecessor of the runabout and was one of the few small spacecraft capable of warp flight during the late 23rd century.

A joint Starfleet and Vulcan design, the ship was conceived as both a long-range courier (with the detachable warp sled) and the new standard shuttle for the refit *Constitution*-class starship (before the development of the smaller *Type-3* shuttlecraft). Vulcan versions sported a distinctive magenta and purple colour scheme.

The warp sled's impulse engines were mounted in the rear of the warp nacelles. The passenger compartment could be detached and docked to a starship via its rear-mounted docking ring.

In 2273, the long-range shuttle *Surak* transported Commander Spock from Vulcan to rendezvous with the *U.S.S. Enterprise* during its mission to intercept V'Ger.



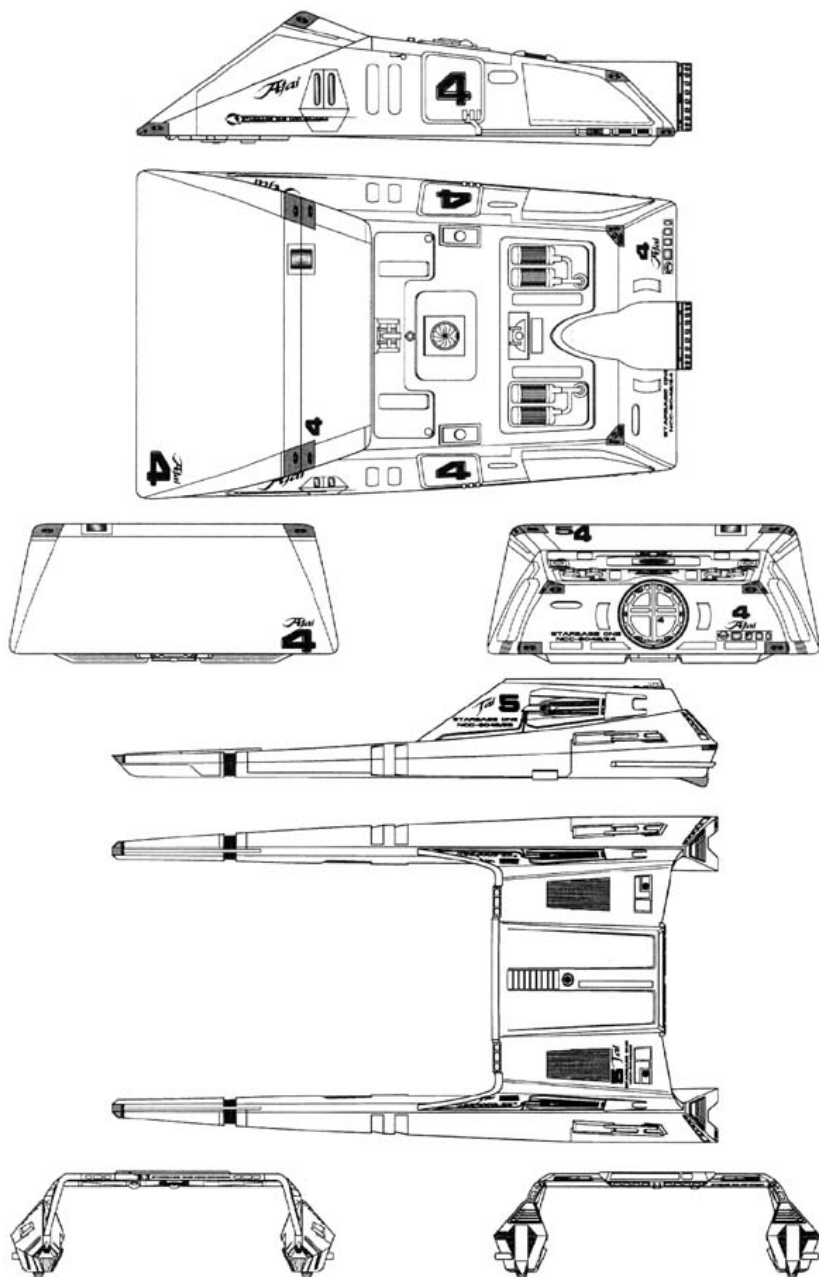

CLASS F SHUTTLECRAFT

**Class:** F**Type:** Personnel Shuttle**Commissioned:** 2245**Production Base:** San Francisco Fleet Yards, Earth**Length:** 6.8 metres**Beam:** 4.2 metres**Height:** 2.4 metres**Mass:** 17 metric tons**Crew:** 1 (plus 6 passengers)**Cruising Speed:** Warp 1**Maximum Speed:** Warp 2**Armament:** None**NCC**

1701/2 Columbus

SB6 Conrad

SB4-0314/2 Da Vinci

1701/6 Einstein †

1701/7 Galileo †

1701/7 Galileo II

SB11-1201/1 Picasso

1701/9 (Name unknown)

NCC-K7 (Name unknown)

† Lost or destroyed

Known Ships

CLASS INFORMATION:

The *Class-F* shuttlecraft was the standard shuttle assigned to *Constitution*-class starships and starbases during the mid-23rd century.

Constructed with a duranium-metal shell, the *Class-F* was propelled by an ion engine, whose power was generated by matter/antimatter reaction. The interior of the craft was divided into two: the larger forward section contained seating for seven passengers, while the smaller aft compartment provided access to the engineering components of the shuttle.

During normal spaceflight, *Class-F* shuttles operated on instruments only, and blast shutters could be lowered over the three forward windows if required.

The *Class-F* shuttlecraft remained in service into the 2270s.



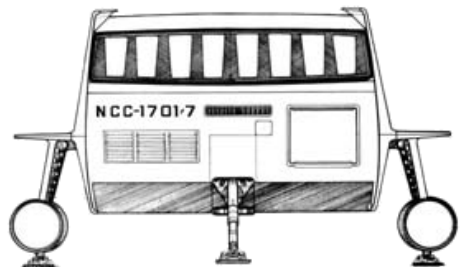
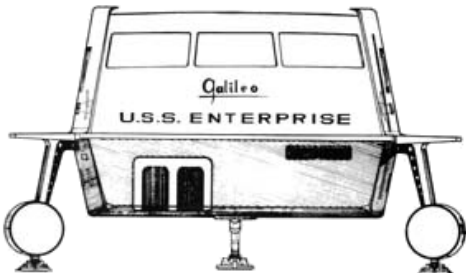
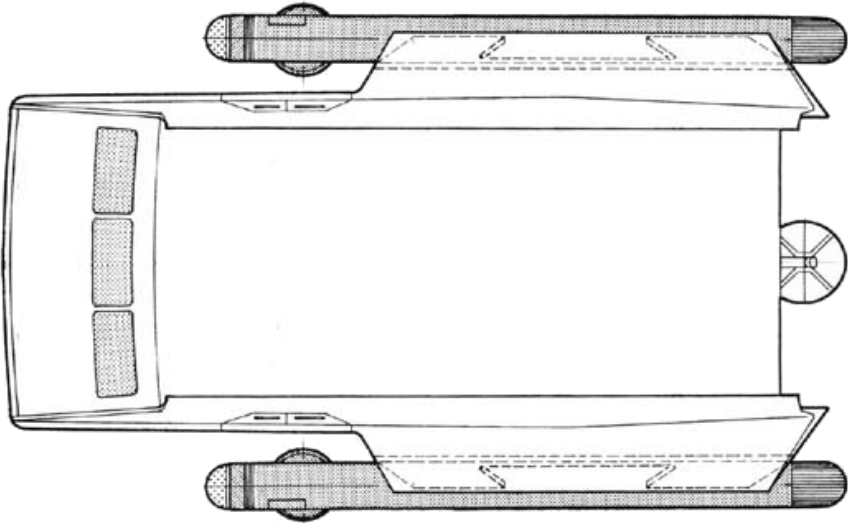
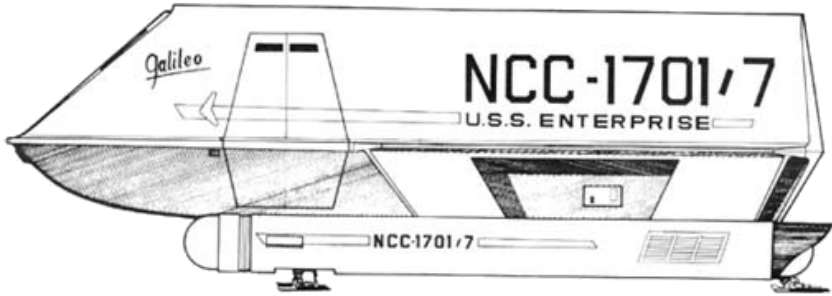

DELTA FLYER



Class: Delta Flyer
Type: Long Range Shuttle
Commissioned: 2375
Production Base: U.S.S. Voyager, Delta Quadrant
Length: 21 metres
Beam: 12.2 metres
Height: 5.3 metres

Mass: 180.6 metric tons
Crew: 1-6
Cruising Speed: Warp 3
Maximum Speed: Warp 6
Armament: 8 Type-V phaser arrays, 1 Mk 25 photon torpedo launcher, photonic missiles

NCC **Known Ships**
74656 Delta Flyer †
74656 Delta Flyer II
† *Lost or destroyed*

CLASS INFORMATION:

The *Delta Flyer* was a unique Starfleet shuttlecraft constructed by the crew of the *U.S.S. Voyager* in the Delta Quadrant in 2375. The vessel was designed to handle environments that would be too hazardous for a standard shuttlecraft.

Conceived by Lt. Tom Paris, the *Delta Flyer* was a blend of Starfleet and Borg technology. It featured an ultra-aerodynamic tetraburnium alloy hull, retractable warp nacelles, parametallic hull plating, unimatrix shielding, and a Borg-inspired weapons system, including photonic missiles. The aft section included a hardpoint for custom-designed mission modules, ranging from lab units to cargo pods. The *Delta Flyer* also carried at least three single-person escape pods.

The original *Delta Flyer* was destroyed by the Borg in 2376, but a replacement was constructed, which operated aboard *Voyager* throughout the rest of its journey home.



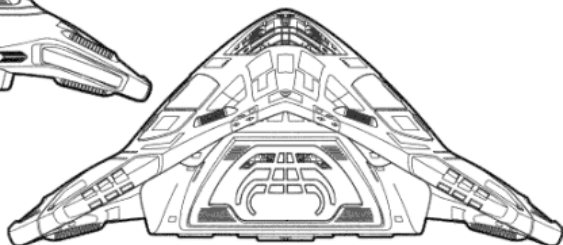
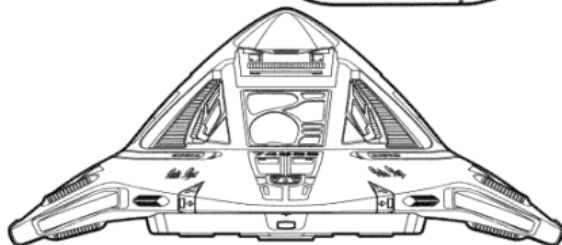
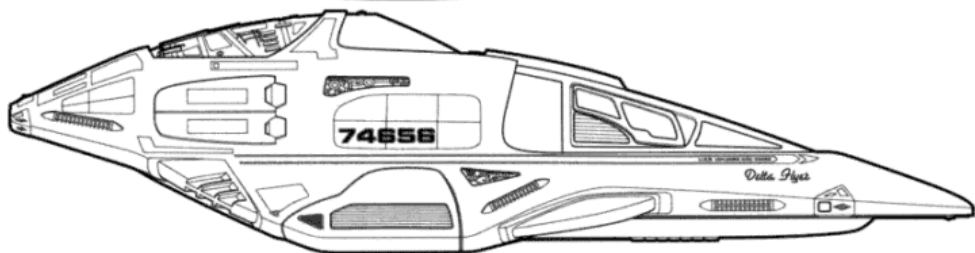
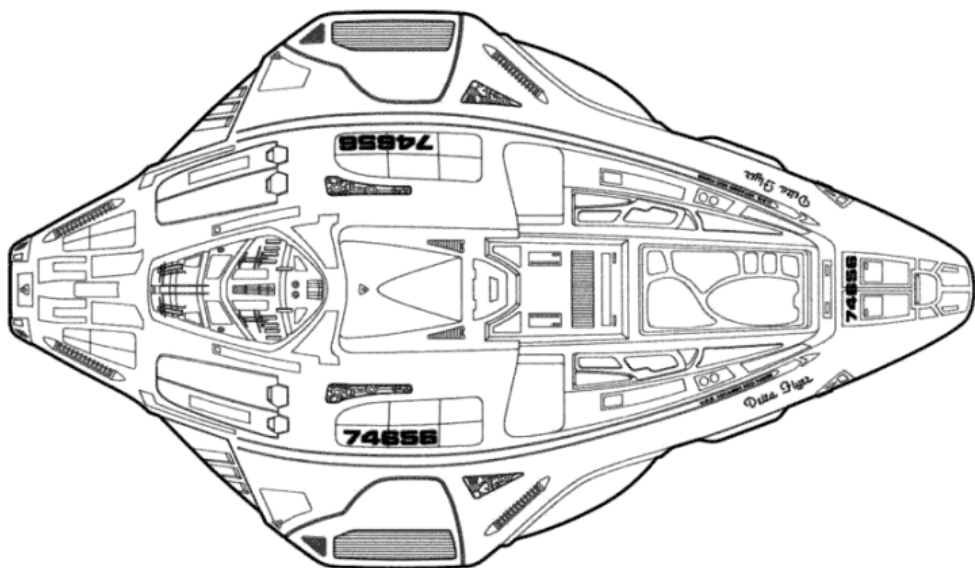

EXECUTIVE SHUTTLE



Class: Executive Shuttle

Type: Orbital Personnel Transport

Commissioned: 2284

Production Base: Various

Length: 26 metres

Beam: 14.7 metres

Height: 6 metres

Mass: 35 metric tons

Crew: 2 (plus 20 passengers)

Cruising Speed: Sublight

Maximum Speed: Sublight

Armament: None

NCC Known Ships

25820 SD-103 *

60597 (Name unknown)

* *Civilian ship (NAR registry)*

CLASS INFORMATION:

The *Executive Shuttle* was a short-range transport used to transfer important personnel and dignitaries, or for deployment from large starships during surface evacuation operations. *Executive Shuttles* were faster, more efficient, and provided greater capacity than shuttlecraft in these roles, but their range was far inferior.

Federation shuttle *SD-103* (NAR-25820) was a civilian orbital transport assigned to Earth Spacedock, and ferried the command crew of the *U.S.S. Enterprise* NCC-1701-A to their vessel moored in Spacedock in 2293.

The *Executive Shuttle* design was still utilised into the 2370s. An *Executive Shuttle* from the *U.S.S. Farragut* NCC-60597 assisted in the evacuation of *U.S.S. Enterprise-D* personnel from the surface of Veridian III, after the latter ship's saucer section had crash-landed there in 2371.



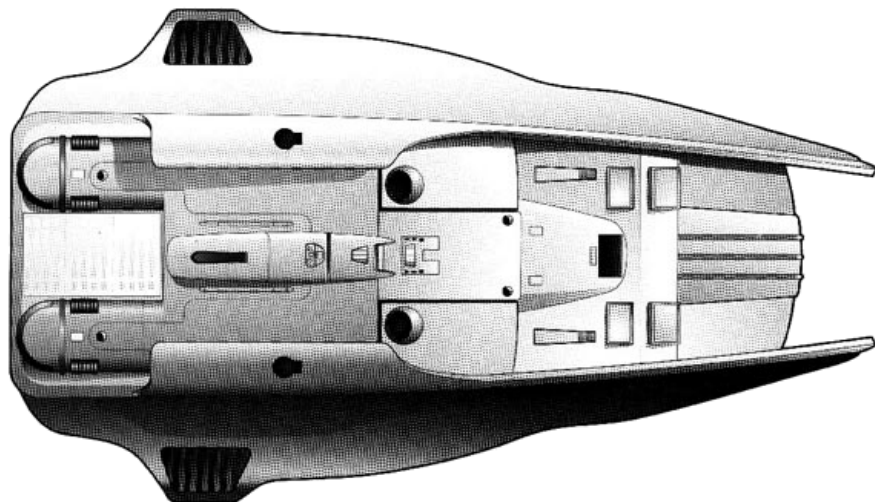
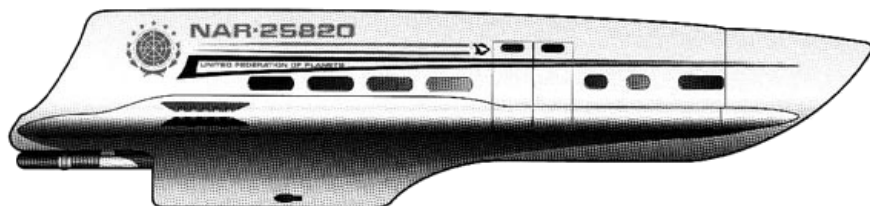
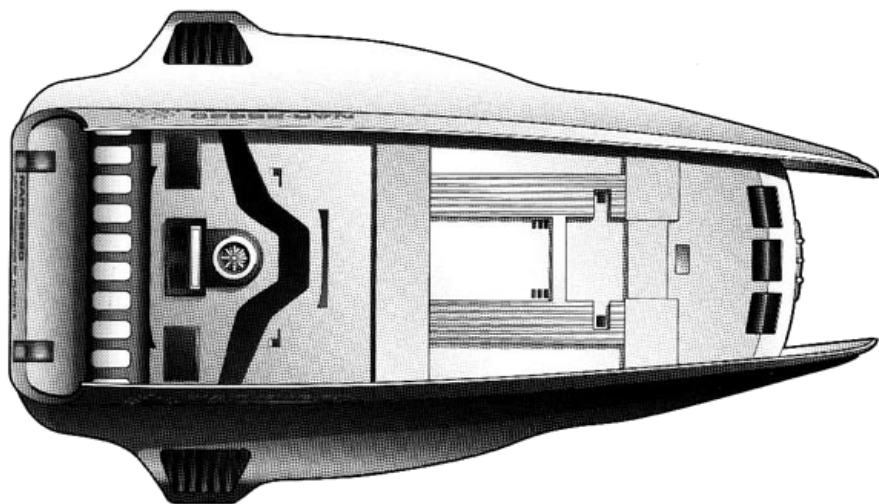

INSPECTION POD

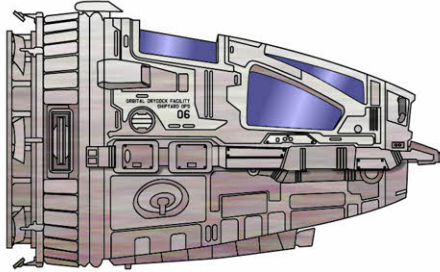

Class: Inspection Pod
Type: Interorbital Personnel Transport
Commissioned: 2148
Production Base: Warp Five Complex, Earth
Length: 3.3 metres
Beam: 2.26 metres

Height: 2 metres
Mass: 2.5 metric tons
Crew: 1 (plus 1 passenger)
Cruising Speed: Sublight
Maximum Speed: Sublight
Armament: None

Known Ships
Orbital 5
Orbital 6

CLASS INFORMATION:

An *Orbital Inspection Pod* was a type of shuttlepod used by Earth Starfleet in the mid-22nd century. At that time matter transportation was not yet in regular use, so *Inspection Pods* and shuttles were a principal method of transferring personnel to and from starships.

The capsule featured a two person cockpit with large observation windows, and a docking port at the rear. Remote manipulators enabled the pod operator to handle cargo and carry out repairs. Propulsion was provide by thrusters. *Inspection Pods* could be launched into orbit atop rockets, then manoeuvred to holding areas, and outfitted for specific duties while in orbit.

NX-class starships carried two *Inspection Pods* for handling cargo, repairs and routine maintenance, which could be launched via the ventral cargo bay doors.



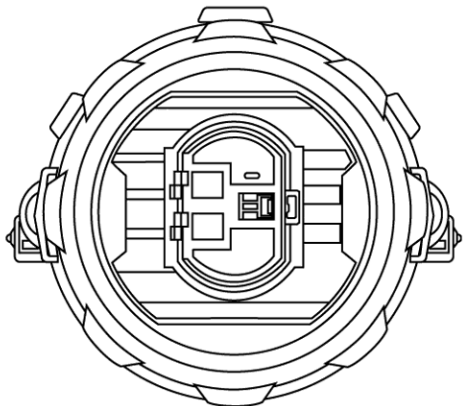
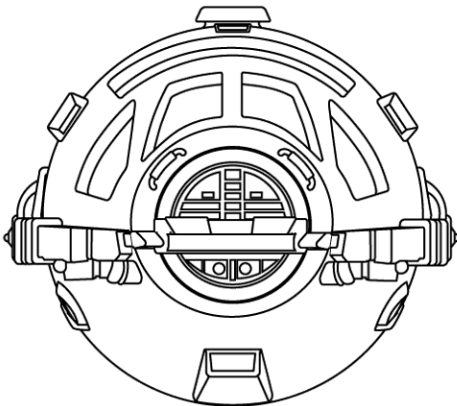
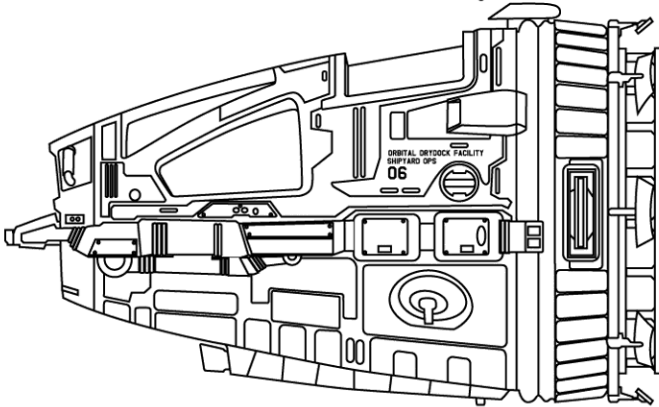
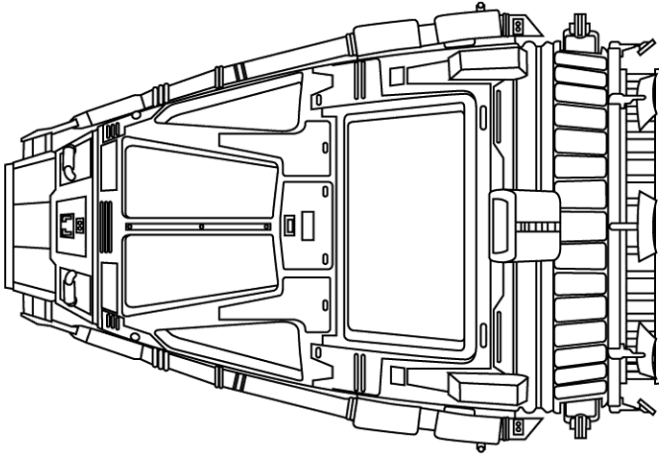

MISSION SCOUT SHIP

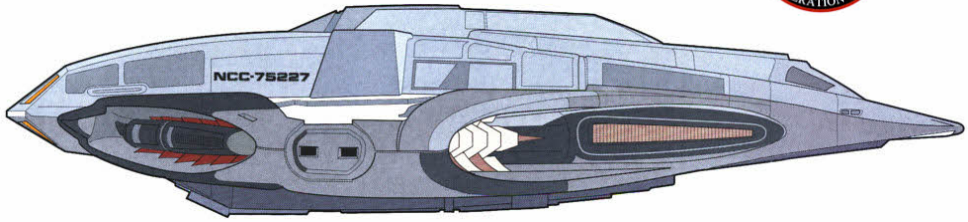

Class: Talon/Venture

Type: Mission Scout

Commissioned: 2373

Production Base: Various

Length: 24.38 metres

Beam: 16.15 metres

Height: 5.03 metres

Mass: 85.7 metric tons

Crew: 1-5

Cruising Speed: Warp 1.5

Maximum Speed: Warp 5

Armament: 4 Type VI phaser arrays, 3 photon micro-torpedo launchers

NCC **Known Ships**

75227 Talon ϕ

ϕ *Non-canon name*

CLASS INFORMATION:

Conceived as a short-range, warp-capable auxiliary science vessel, the *Talon*-class mission scout (also known as the *Venture*-class) is designed primarily for reconnaissance and exploration. Like the similar-sized *Danube*-class runabout, the mission scout can be carried in the shuttlebays of larger starships. The vessel is typically made available for long-term research - its small size making it ideal for planetary survey missions, first contact programs and cultural survey duties.

The spaceframe is constructed around the primary sensor system, which allows research and analysis at a level typically reserved for much larger vessels. The mission scout is well armed for a small vessel, and was used in the Dominion War to locate Jem'Hadar activity and recon star systems in advance of Starfleet attack.

The prototype was used in the cultural study of the Ba'ku planet in the Briar Patch in 2375.



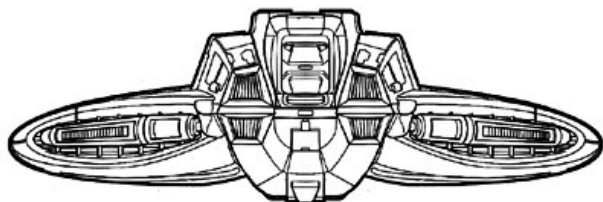
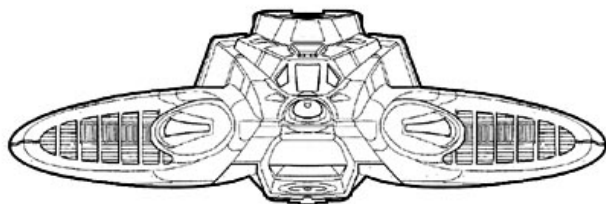
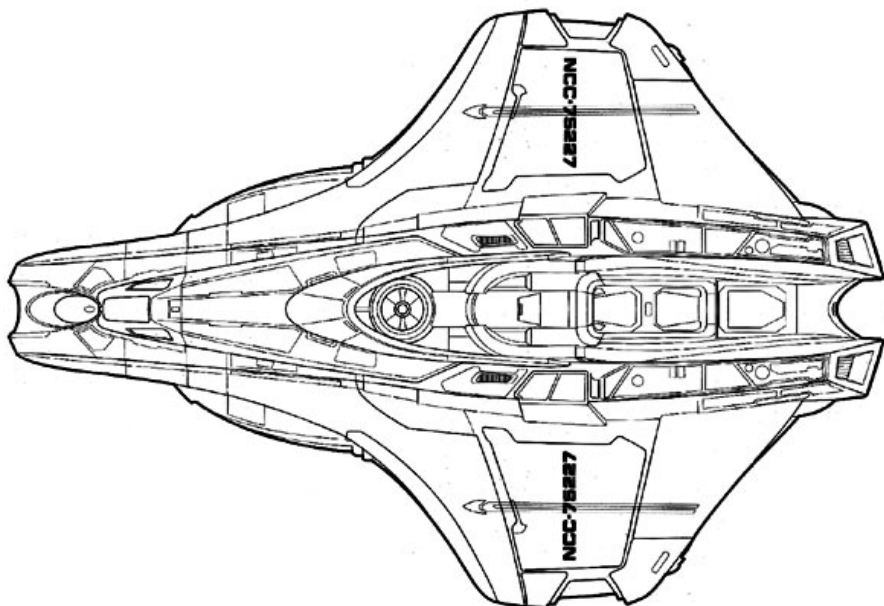
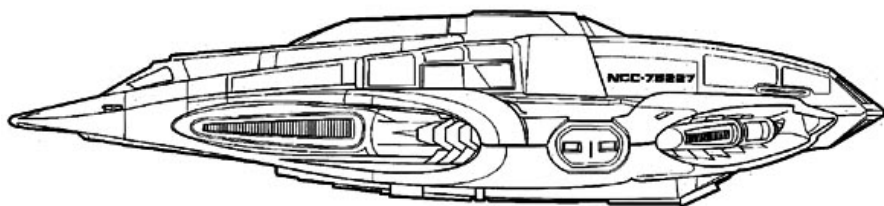

PEREGRINE CLASS FIGHTER

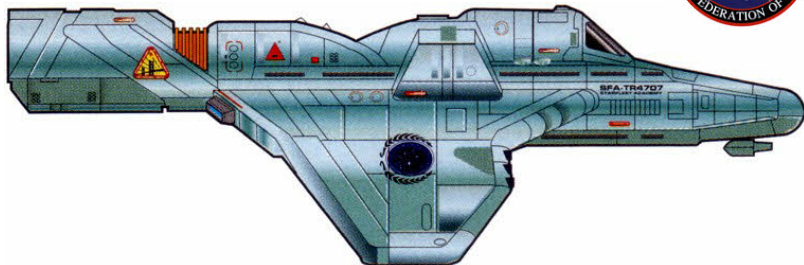

Class: Peregrine
Type: Attack Fighter/Courier
Commissioned: 2367
Production Base: Various
Length: 30.2 metres
Beam: 28.5 metres
Height: 12.7 metres
Mass: 27 metric tons

Crew: 1-2
Cruising Speed: Warp 4
Maximum Speed: Warp 5.1
Armament: 3 Type VIII phaser emitters, 3 photon/quantum micro-torpedo launchers

SFA Known Ships
TR4707 (Name unknown)

CLASS INFORMATION:

The *Peregrine*-class attack fighter is a small, manoeuvrable, heavily-armed assault vessel. Though warp-capable, these ships are usually transported to the site of a battle by a carrier vessel (*Akira* and *Shelley*-class starships often served in this role during the Dominion War) and deployed in squadrons as forward waves of attack.

The *Peregrine* carries an impressive arsenal for a small craft, with pulse phasers and quantum micro-torpedo launchers mounted in the wings and nose. The ship has a pair of large impulse engines at the rear, flanked by the warp nacelles. The cockpit is in the forward section.

In 2370, the Maquis acquired several *Peregrine*-class vessels for use against the Cardassians. The Maquis armed the fighters with whatever weapons were available, and used the ships as both interceptors and couriers.



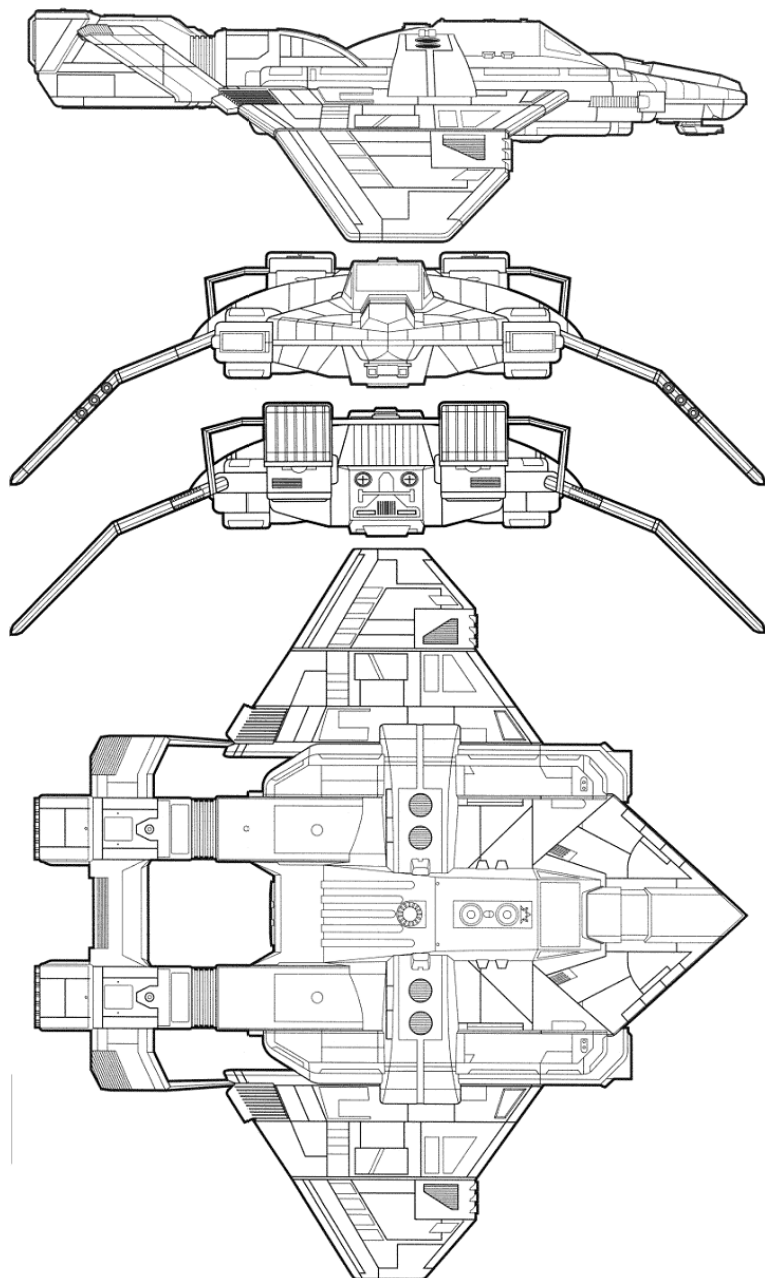

SOVEREIGN CAPTAIN'S YACHT



Class: Sovereign-class
Captain's Yacht
Type: Diplomatic
Courier/Transport
Commissioned: 2369
Production Base: San
Francisco Fleet Yards, Earth
Length: 33.5 metres

Beam: 26.2 metres
Height: 6.3 metres
Mass: 125 metric tons
Crew: 1-3
Cruising Speed: Warp 6
Maximum Speed: Warp 9
Armament: 4 Type IV phaser
arrays, 1 tachyon burst emitter

NCC **Known Ships**
1701-E *Cousteau*

CLASS INFORMATION:

The *Captain's Yacht* on a *Sovereign*-class starship is a large auxiliary craft that is normally docked on the ventral side of the saucer section.

The *Captain's Yacht* was designed as a multipurpose vehicle, but is principally used for diplomatic missions or for the captain's personal use. When docked the yacht uses power from the starship, however once launched it is a completely independent craft, equipped with transporters, phasers, and impulse and warp engines. The nacelles move down into their flight position once the craft is deployed. The *Captain's Yacht* is capable of atmospheric flight and planetfall, and can be flown by a single pilot. It has a cockpit, passenger and cargo areas, and a small transporter.

The U.S.S. *Enterprise* NCC-1701-E's *Captain's Yacht* was called the *Cousteau*. In 2375, Captain Jean-Luc Picard and his senior staff took the *Cousteau* to the Ba'ku planet as part of a plan to prevent the forced relocation of the Ba'ku by the Son'a.



Plans SOVEREIGN CAPTAIN'S YACHT

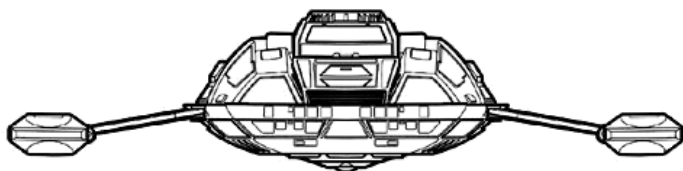
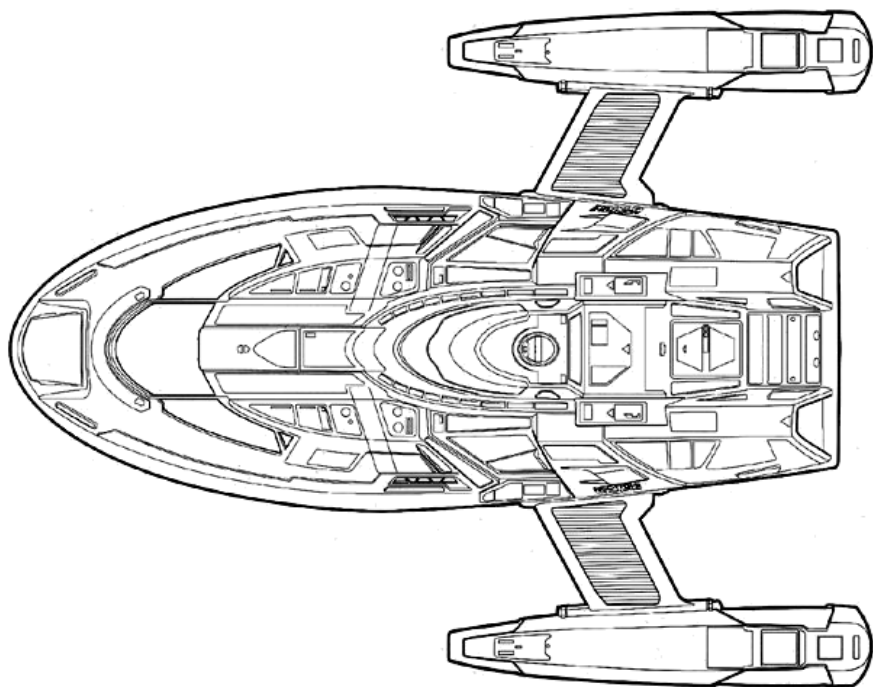
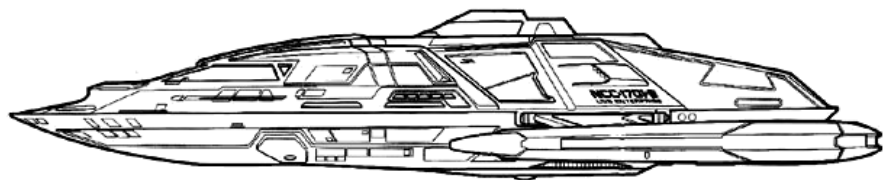

TRAVEL POD



Class: Travel Pod
Type: Interorbital Personnel Transport
Commissioned: 2270
Production Base:
Length: 4.4 metres
Beam: 3.26 metres
Height: 2.85 metres

Mass: 2.85 metric tons
Crew: 1 (plus 7 passengers)
Cruising Speed: 680 m/s
Maximum Speed: 10 km/s
Armament: None

Known Ships
Travel Pod 05
Travel Pod 06

CLASS INFORMATION:

A *Travel Pod* was a small Federation shuttlepod used during the 23rd century to transfer personnel between orbital facilities and spaceships.

The *Travel Pod* was designed to complement the orbital shuttle also produced in the 2270s. Where the orbital shuttle was designed to operate both in space and a planetary atmosphere, the *Travel Pod* was confined purely to space. The bulky shape was designed to maximize internal volume, with no attempt to give it any aerodynamic qualities. Propulsion was provided by microthrusters.

The design featured a standard docking and entry hatch at the rear, simple flight controls at the forward end, and an artificial gravity generator under the floor. The front of the vessel was dominated by a large viewport.



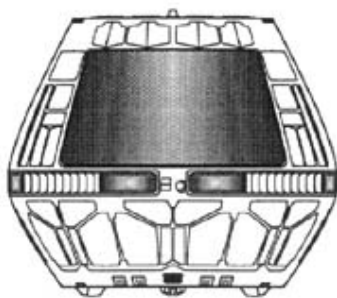
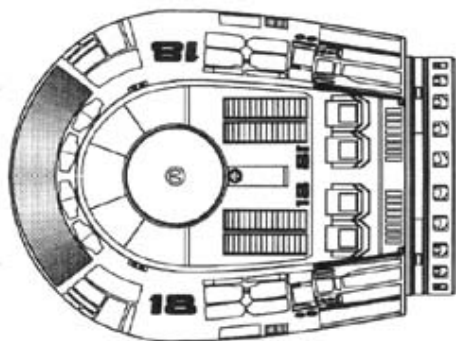
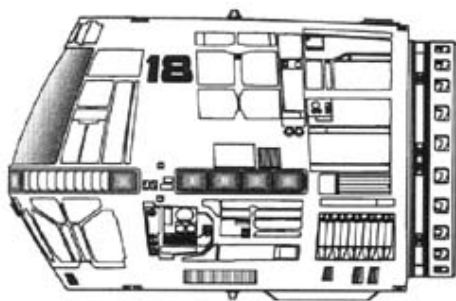

TYPE 1 SHUTTLEPOD

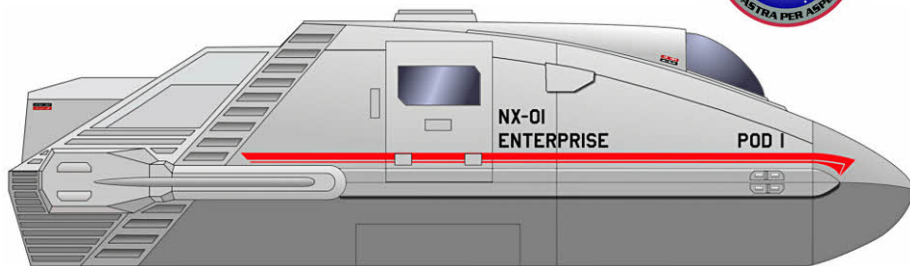

Class: Type-1
Type: Personnel Shuttle
Commissioned: 2150
Production Base: Warp Five Complex, Earth
Length: 6 metres
Beam: 2.75 metres
Height: 1.7 metres

Mass: 3.76 metric tons
Crew: 1 (plus 6 passengers)
Cruising Speed: Sublight
Maximum Speed: 0.25 c
Armament: 2 TDM-8 plasma cannons

NX/NC	Known Ships
NX-01/1	Pod 1
NX-01/2	Pod 2
NC-05	(Name unknown)

CLASS INFORMATION:

In the mid-22nd century, shuttlepods were the primary method for the transport of personnel between starships and planetary surfaces, as transporter technology was in its infancy and not considered entirely reliable.

Type-1 shuttlepods could carry six passengers, though conditions aboard the vehicles were cramped. Enough rations were stored to last two crew for ten days. The craft were equipped with retractable wings, an impulse drive capable of one quarter light speed, and twin plasma cannons for defence. Access was via a hatch on either side and a docking port on the dorsal surface. Universal translators were not usually stored aboard.

NX-class starships usually carried two shuttlepods in a ventral bay, with two more in storage. The craft were deployed and recovered using a magnetic docking arm.



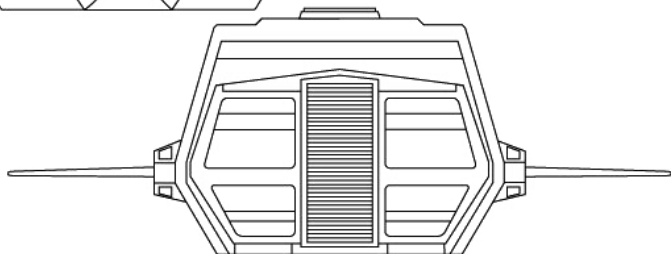
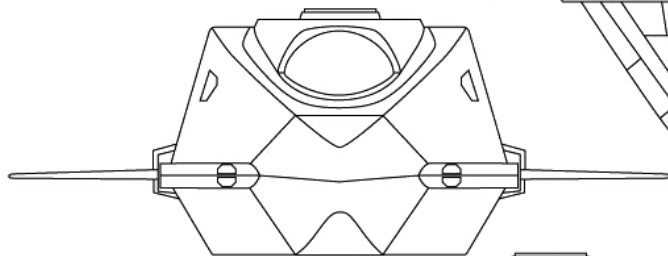
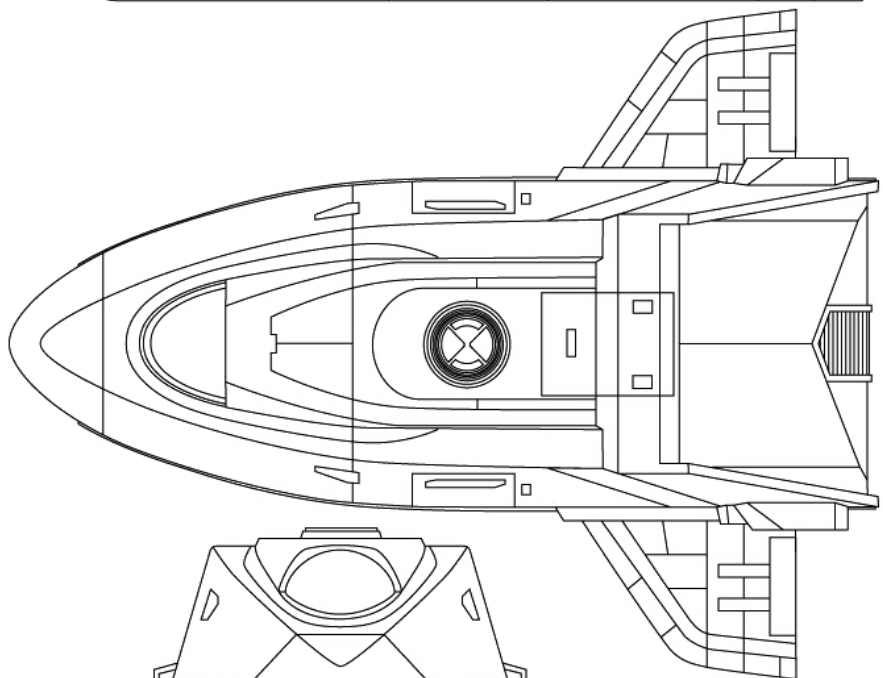
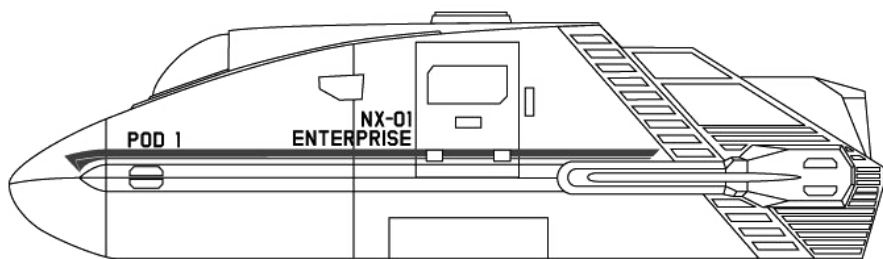

TYPE 3 SHUTTLECRAFT

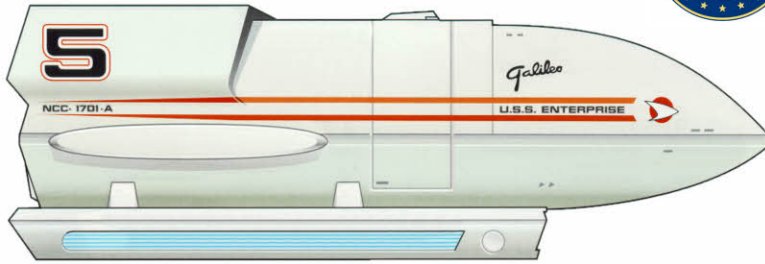

Class: Type-3

Type: Personnel Shuttle

Commissioned: 2280

Production Base: San Francisco Fleet Yards, Earth

Length: 9.1 metres

Beam: 4.7 metres

Height: 2.9 metres

Mass: 10 metric tons

Crew: 2 (plus 10 passengers)

Cruising Speed: Sublight

Maximum Speed: Sublight

Armament: 1 Type III Phaser emitter

NCC

1701-A/3

1701-A/5

† *Lost or destroyed*

Known Ships

Copernicus †

Galileo

CLASS INFORMATION:

During the 2280s the *Type-3* shuttlecraft superseded the *Class-F* and *Atai*-class vessels as the standard shuttle employed by Starfleet. The *Type-3* was useful for a large array of missions due to its versatility, speed, range, and large interior space.

The wedge-shaped spaceframe was equipped with three doors: personnel access gangways on either side, and a large cargo hatch at the rear. Navigational sensor pods were situated on either side of the main body, with further arrays on the base of the shuttle. Impulse propulsion was provided by the drive section on the upper rear of the vessel, with supplementary micro-nacelles attached to the lower sides. A single phaser pod was situated on top of the craft.

The *Type-3* was among the standard complement of auxiliary vessels aboard refit *Constitution*-class starships as of 2287, and the successful spaceframe design would become the basis for the *Type-6* and *Type-8* shuttles of the 24th century.



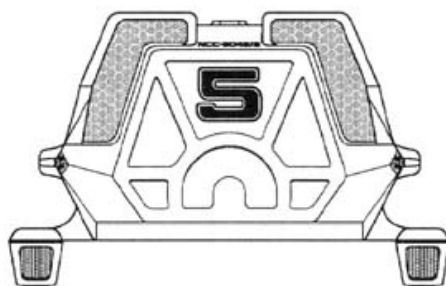
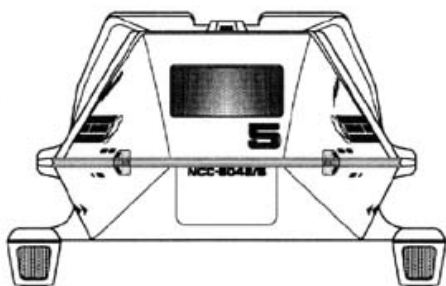
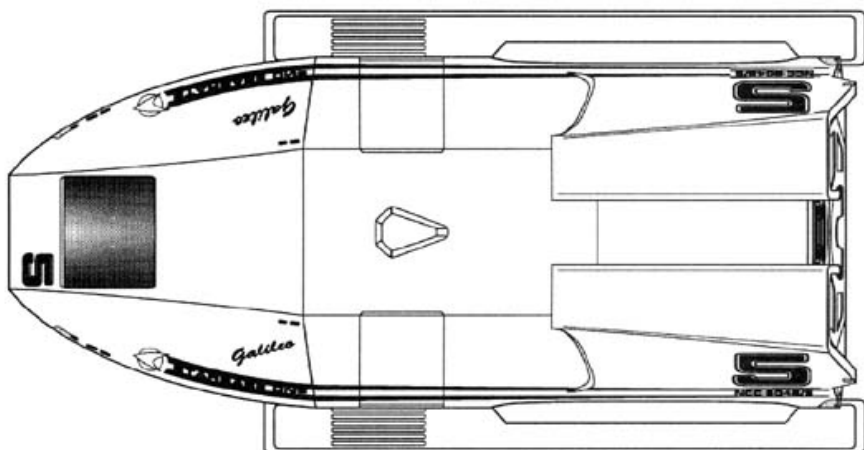
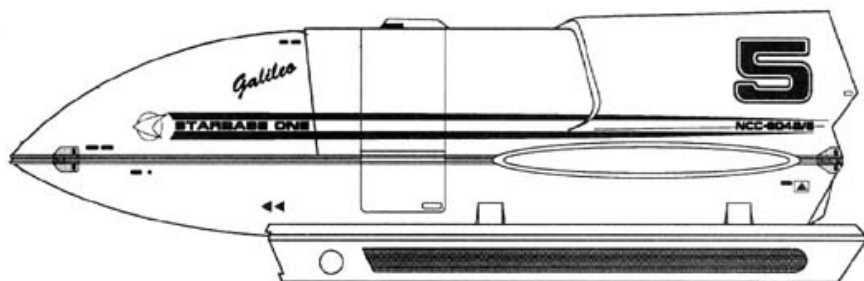

TYPE 6 SHUTTLECRAFT

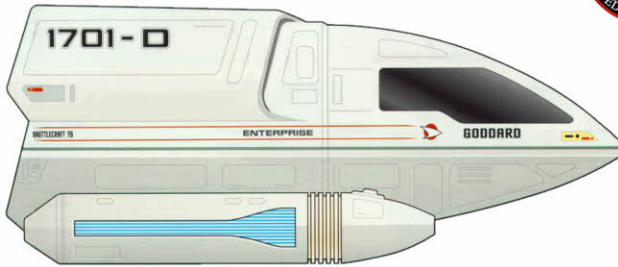

Class: Type-6

Type: Light Short-Range Personnel Shuttle

Commissioned: 2357

Production Base: Utopia Planitia Fleet Yards, Mars

Length: 6 metres

Beam: 4.4 metres

Height: 2.7 metres

Mass: 3.38 metric tons

Crew: 2 (plus 2-6 passengers)

Cruising Speed: Warp 1.2

Maximum Speed: Warp 2

Armament: 2 Type IV phaser emitters (optional)

NCC

Known Ships

	Berman
1701-D/03	Curie †
1701-D/09	Fermi †
	Feynman
1701-D/07	Galileo
1701-D/15	Goddard
	Hypatia
1701-D/03	Justman
1701-D/15	Magellan †
	Pillar
74656/05	Sacajawea
RS-47	Verne
1701-D/04	(Name unknown)
71325	(Name unknown)
	† <i>Lost or destroyed</i>

CLASS INFORMATION:

A short-range vessel, the *Type-6* shuttlecraft was an evolution of successful earlier designs, such as the *Type-3*, and was the basis for the later *Type-8*.

The *Type-6* had a duranium/tritanium hull, and featured key redundant systems, including operations and sensors.

It also introduced isolar computer systems into shuttlecraft service. The craft could be fitted with a portable transporter, and this, along with phasers and shields, was fitted as standard by 2374. Entry was via a large hatch at the rear.

Type-6 shuttles were part of the standard loadout aboard *Galaxy*, *Nebula*, and *Intrepid*-class starships, as well as space stations and other Federation facilities.



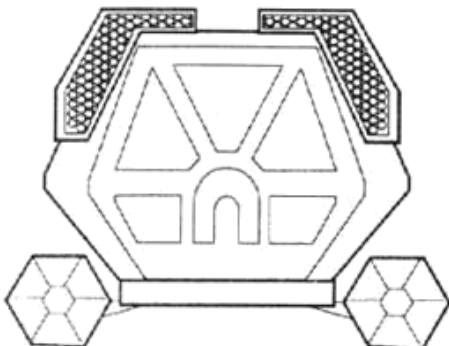
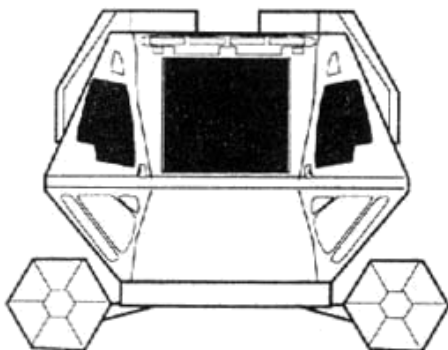
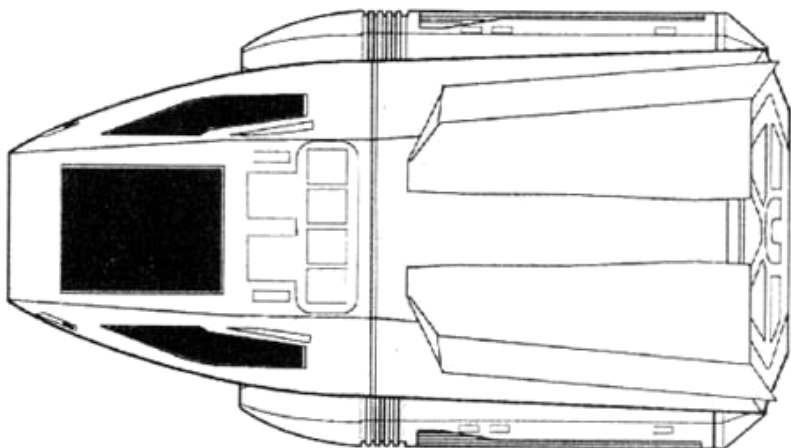
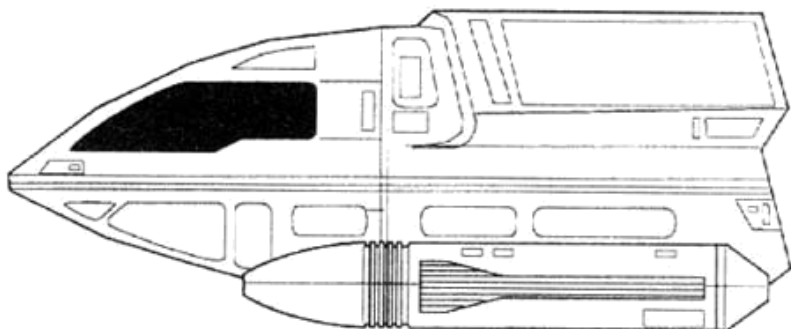

TYPE 7 SHUTTLECRAFT

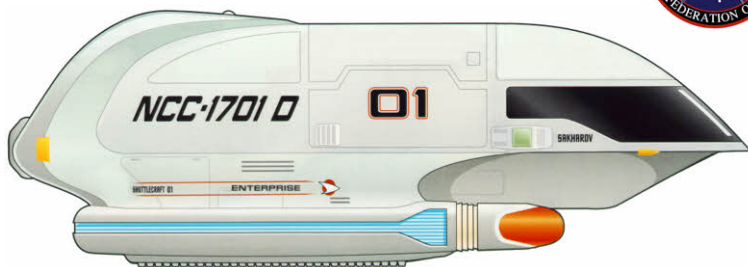

Class: Type-7
Type: Medium Short-Range Personnel Shuttle
Commissioned: 2357
Production Base: Utopia Planitia Fleet Yards, Mars
Length: 8.5 metres
Beam: 3.6 metres

Height: 2.7 metres
Mass: 3.96 metric tons
Crew: 2 (plus 2-6 passengers)
Cruising Speed: Warp 1.75
Maximum Speed: Warp 2
Armament: 2 Type V phaser emitters (optional)

NCC	Known Ships
1701-D/01	Sakharov
1701-D/02	(Name unknown)
1701-D/03	Copernicus
1701-D/05	(Name unknown)
1701-D/06	(Name unknown)
1701-D/13	†(Name unknown)
1701-D/15	Hawking
2544/10	D'Alison
67016/07	Kotoi †
	† Lost or destroyed

CLASS INFORMATION:

The *Type-7* shuttlecraft was a short to medium-range auxiliary vessel, and a larger and heavier counterpart to the *Type-6*.

Type-7 shuttles were typically unarmed and had minimal deflector shield coverage. They were fitted with escape transporters, which could be reconfigured for standard use if necessary. The impulse engine was located at the stern of the vessel.

The cockpit area had two seats, each with a small console and window. A large display in the centre of the front bulkhead provided navigational information and acted as a viewscreen. The aft area contained further seating and sensor control.

The *Type-7* was a standard shuttlecraft aboard *Galaxy*, *Excelsior*, and *Nebula*-class starships.

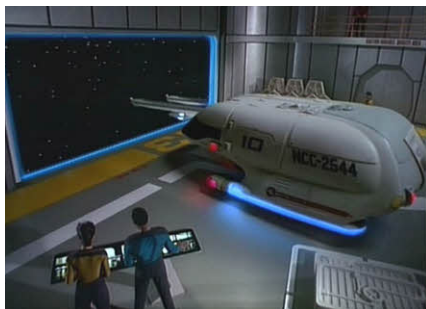

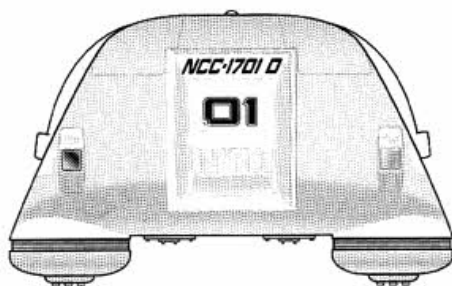
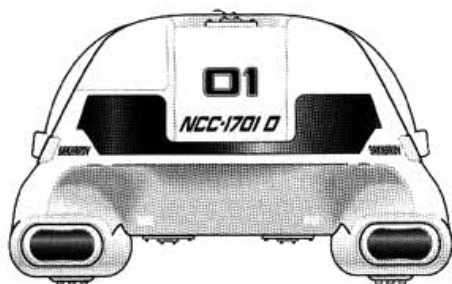
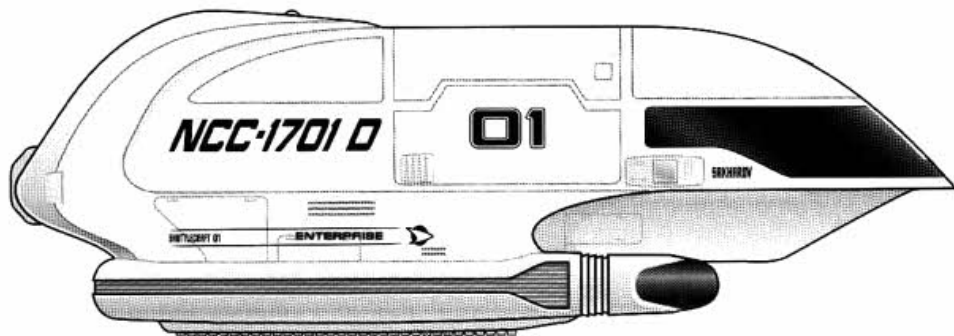

TYPE 8 SHUTTLECRAFT



Class: Type-8

Type: Personnel Shuttle

Commissioned: 2371

Production Base: Utopia

Planitia Fleet Yards, Mars

Length: 7 metres

Beam: 4.7 metres

Height: 2.8 metres

Mass: 3.47 metric tons

Crew: 2 (plus 2-6 passengers)

Cruising Speed: Warp 2.6

Maximum Speed: Warp 3

Armament: 2 Type IV phaser emitters (optional)

NCC

Known Ships

Drake †

74656/01 Tereshkova

† *Lost or destroyed*

CLASS INFORMATION:

A development of the successful *Type-6* design, the more advanced and streamlined *Type-8* shuttlecraft was introduced for use on *Intrepid*-class starships.

Type-8 shuttles are composed of duranium, magnesite and carbon residue. They are not normally armed, but can be fitted with dual phaser emitters.

The *Type-8*'s computer system incorporates the bio-neural gel pack technology used by its mother ship, as a replacement for the isolar chips of the *Type-6*. The more advanced and efficient warp nacelles are also modelled on the *Intrepid*'s design. Internally the *Type-8*'s layout is very similar to the *Type-6*, with a slightly larger passenger and cargo compartment. The craft is fitted with a medium-range transporter.



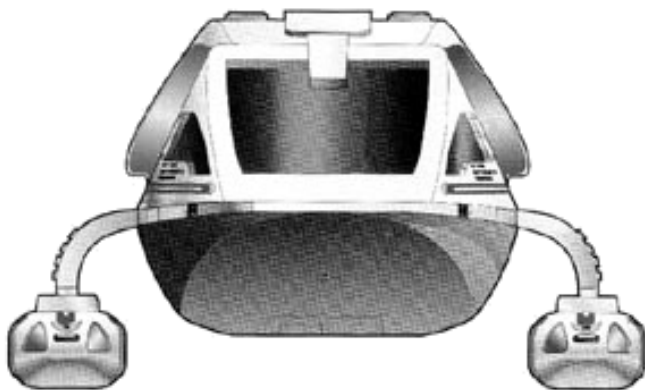
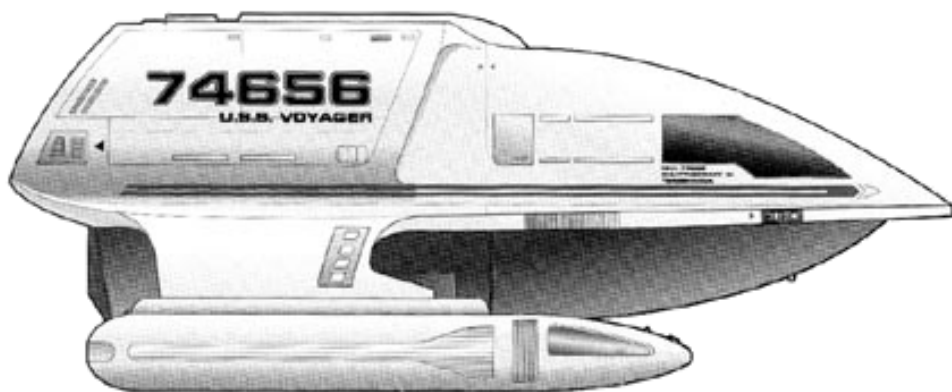

TYPE 9 SHUTTLECRAFT

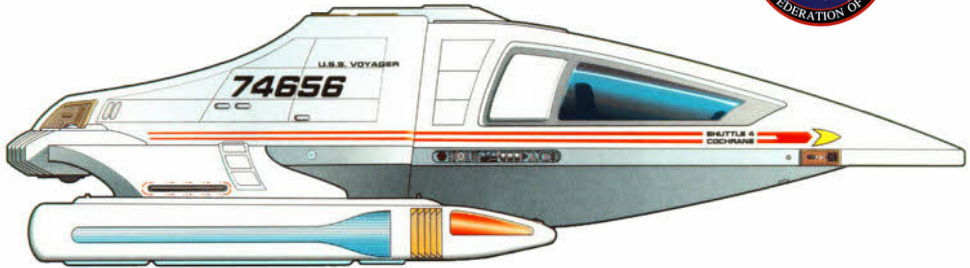

Class: Type-9/Class-2
Type: Personnel Shuttle
Commissioned: 2370
Production Base: Utopia Planitia Fleet Yards, Mars
Length: 8.5 metres
Beam: 4.5 metres
Height: 2.3 metres

Mass: 2.61 metric tons
Crew: 2 (plus 2 passengers)
Cruising Speed: Warp 3
Maximum Speed: Warp 4
Armament: 3 Type VI phaser arrays, 2 Mk 25 photon micro-torpedo launchers (optional)

NCC **Known Ships**
74656/04 Cochrane †
 Dawkins
74656/05 Harris
† *Lost or destroyed*

CLASS INFORMATION:

The *Type-9* shuttlecraft is a fast, long-range auxiliary craft ideal for personnel transport, scouting and reconnaissance. It is often referred to as a *Class-2* shuttle.

Older *Class-2* vessels were widely used during the 2360s at Starfleet Academy, and though fast and manoeuvrable were notorious for their cramped interiors. The *Type-9* features a streamlined hull and nacelles, and a pronounced forward deflector dish that houses a compact long-range sensor. *Type-9* shuttlecraft are equipped with phasers as standard, and can be retrofitted with photon torpedoes. They also carry a medium-range transporter. Most of the components of these types of shuttle were designed to be easily replicated, making them easy to replace.

In 2372, the crew of the *U.S.S. Voyager* discovered a new form of dilithium that enabled a modified *Class-2* shuttle to achieve speeds significantly past warp nine.



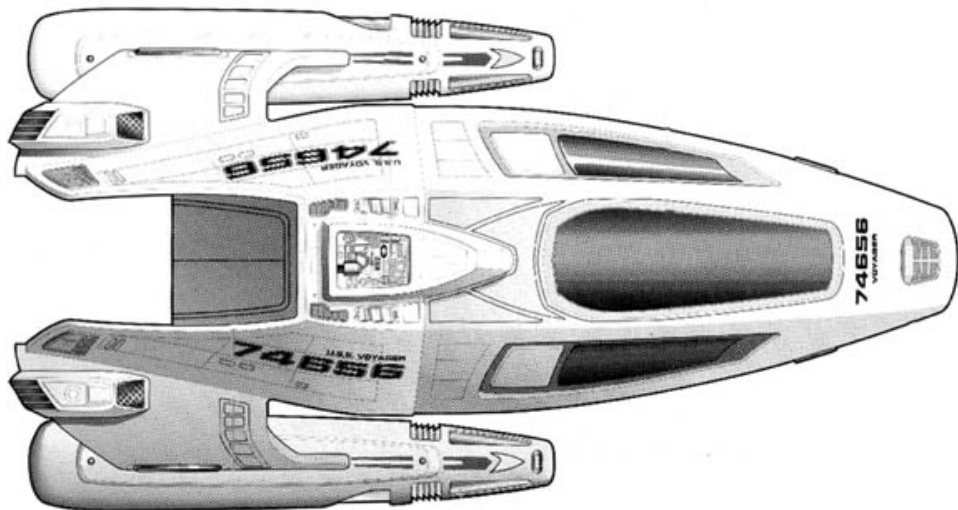
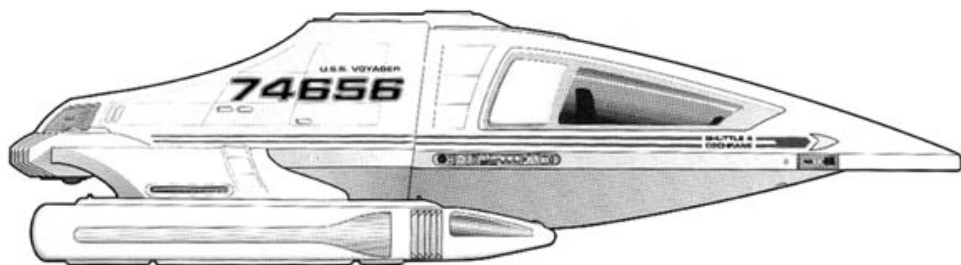

TYPE 10 SHUTTLECRAFT



Class: Type-10

Type: Personnel Shuttle

Commissioned: 2373

Production Base: Antares
Fleet Yards, Antares IV

Length: 9.64 metres

Beam: 5.82 metres

Height: 3.35 metres

Mass: 19.73 metric tons

Crew: 4

Cruising Speed: Warp 3

Maximum Speed: Warp 5

Armament: 2 Type V phaser
arrays, 2 Mk 25 photon/quantum
micro-torpedo launchers

NCC

74205/01

Known Ships

Chaffee

CLASS INFORMATION:

The *Type-10* shuttle was developed as an armoured support craft for use aboard the *Defiant*-class escort, and takes many of its design cues from its mother ship.

The spaceframe is based on the established *Type-6* design, with armoured and recessed engine pods modelled after the *Defiant's* own warp nacelles. The impulse drive is likewise a smaller version of the *Defiant's*. Defensive systems include phasers, micro-torpedo launchers, shields and jamming devices. Onboard systems include a shortened version of the *Danube*-class runabout computer core, and provisions have been made for bio-neural gel pack peripherals and upgrades.

The prototype *U.S.S. Defiant* carried a single *Type-10* shuttle, housed in a bay built into Decks 3 and 4 and released via launch doors in the base of the starship.



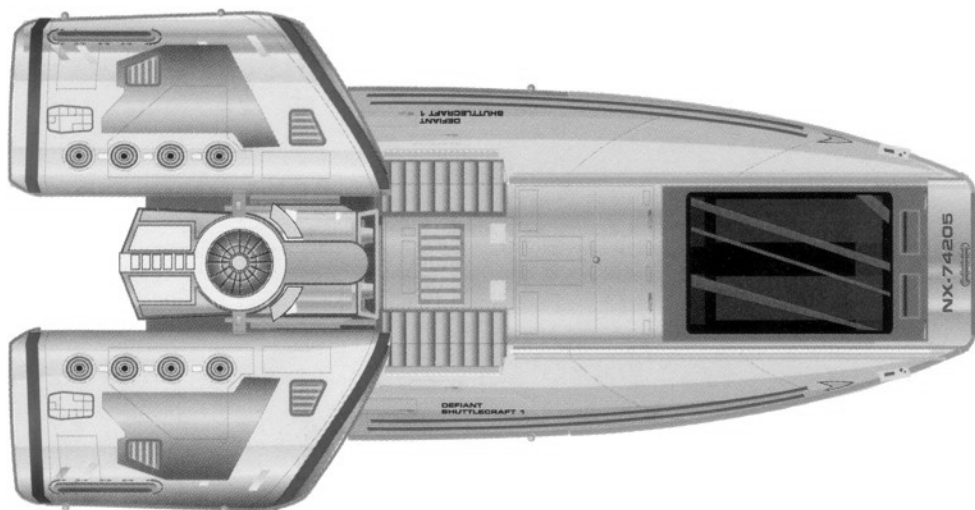

TYPE 11 SHUTTLECRAFT

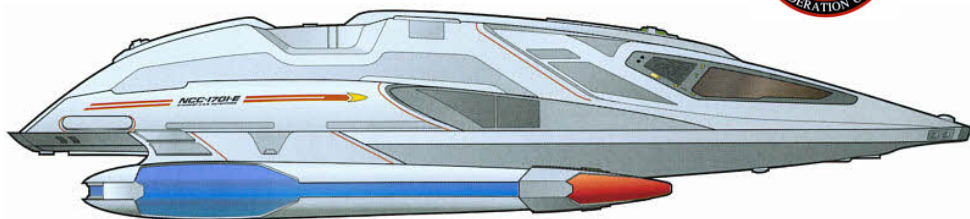

Class: Type-11
Type: Heavy Personnel Shuttle
Commissioned: 2369
Production Base: San Francisco Fleet Yards, Earth
Length: 16 metres
Beam: 9.78 metres
Height: 4.25 metres

Mass: 28.11 metric tons
Crew: 4 (plus 6 passengers)
Cruising Speed: Warp 5
Maximum Speed: Warp 6
Armament: 4 Type V phaser arrays, 2 Mk 25 photon micro-torpedo launchers

NCC **Known Ships**
1701-E (Name unknown)

CLASS INFORMATION:

The *Type-11* personnel shuttle is equipped with all the systems of a starship within the shell of an auxiliary craft. The design represents an intermediate step between a traditional small shuttle and a runabout, and the frame and components blend aspects of both the *Type-9* and *Danube*-class vessels.

The *Type-11* is a true multi-role vessel, and features impressive shielding, multiple phaser emitters, micro-torpedo launchers and a warp drive capable of speeds faster than previous shuttle designs. Both the ventral and dorsal surfaces of the shuttle house magnaclamp docking ports capable of linking up to other ships. A two-person transporter and a large aft compartment with a replicator add to the shuttle's versatility.

Type-11 shuttles are part of the standard complement of auxiliary craft aboard *Sovereign*-class starships.



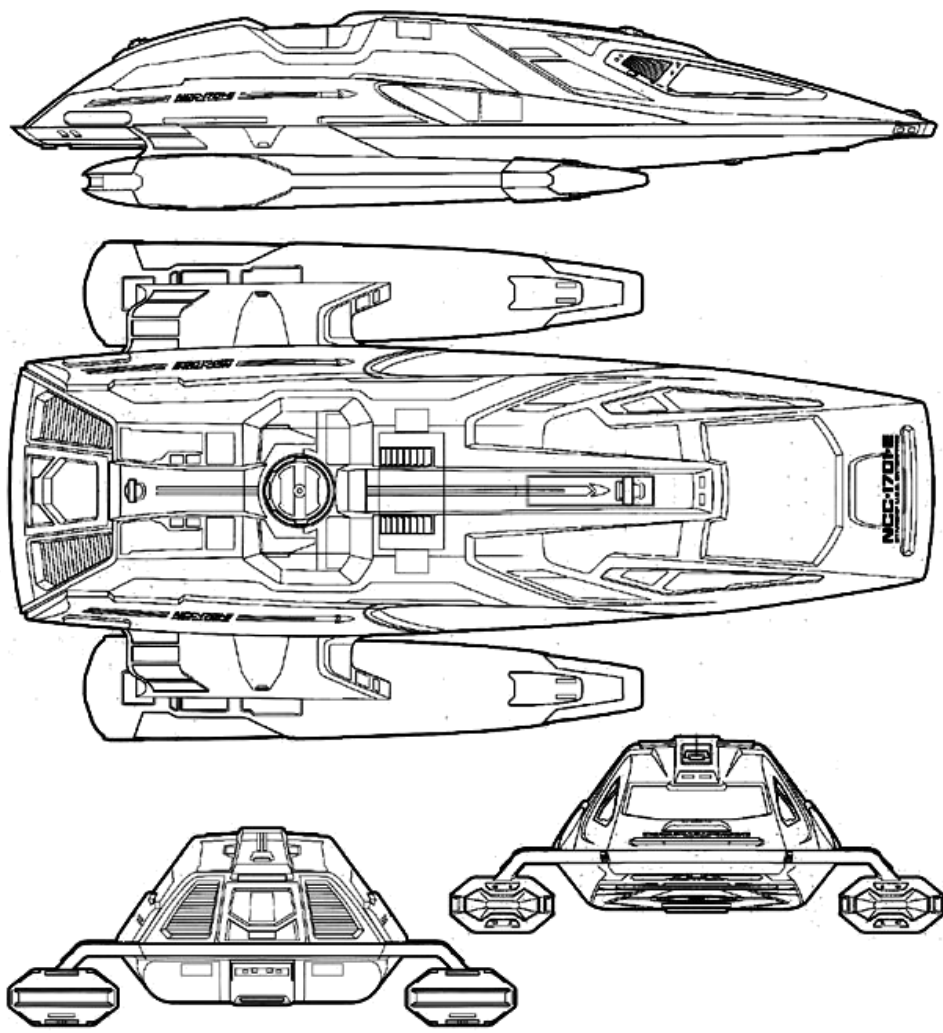

TYPE 15 SHUTTLEPOD



Class: Type-15
Type: Light Short-Range
Sublight Shuttle

Commissioned: 2357

Production Base: Starbase
134 Integration Facility, Rigel VI

Length: 3.6 metres

Beam: 2.4 metres

Height: 1.6 metres

Mass: 0.86 metric tons

Crew: 1-2

Cruising Speed: Sublight

Maximum Speed: 12,800 m/s

Armament: 2 Type IV phaser
emitters

NCC Known Ships

1701-D	Campbell
45167	Cousteau
1701-D/05	El-Baz †
1701-D/09	Ley
1701-D/07	Onizuka
1701-D/12	Pike †
1701-D/03	Voltaire †
1701-D/01	(Name unknown)

† *Lost or destroyed*

CLASS INFORMATION:

The *Type-15* shuttlepod was a small one or two-person craft primarily used for short-range transport of personnel and cargo, as well as for extravehicular inspections of Federation starships, stations and associated facilities.

The *Type-15* had a small cargo space, accessed through a hatch at the rear of the craft, which could be used for carrying supplies. Some configurations included space for an additional passenger in the cargo area. Defensive systems included deflector shields and two phaser emitters. In addition to a primary deuterium supply, power was provided by three sarium krellide cells.

The *Type-15* was one of three similar classes of shuttlepod, with the *Type-15A* and *Type-16* variants featuring slightly superior specifications. *Type-15s* were part of the standard complement on *Galaxy*, *Renaissance*, and *Nebula*-class starships.

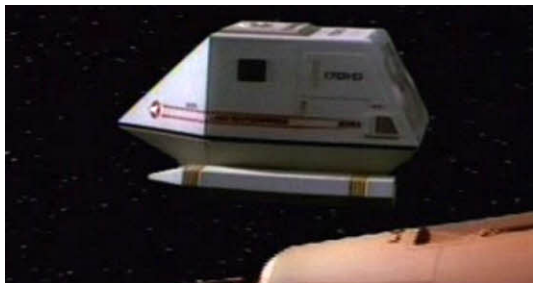

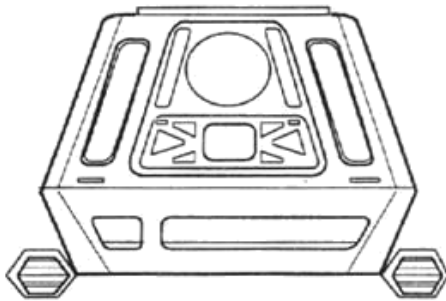
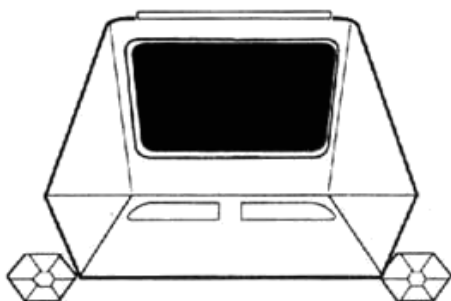
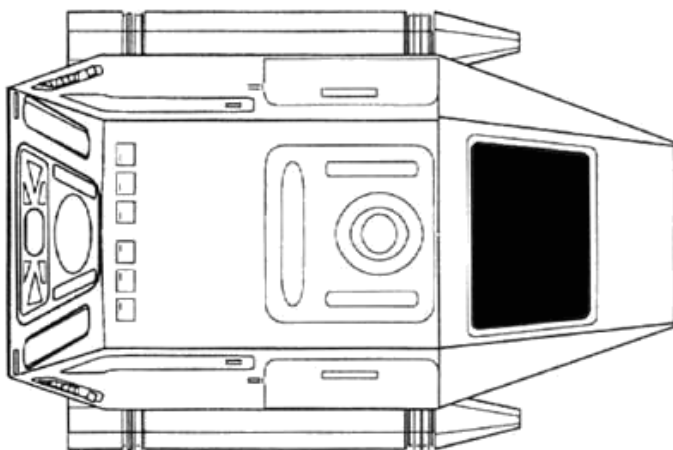
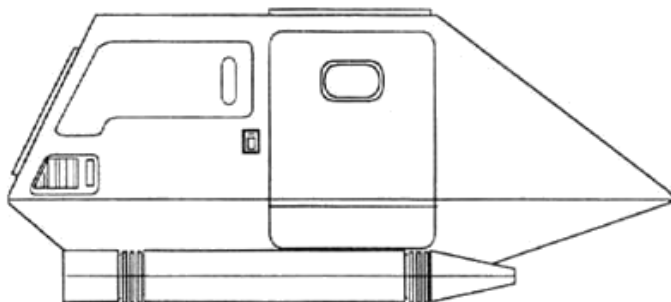

TYPE 18 SHUTTLEPOD

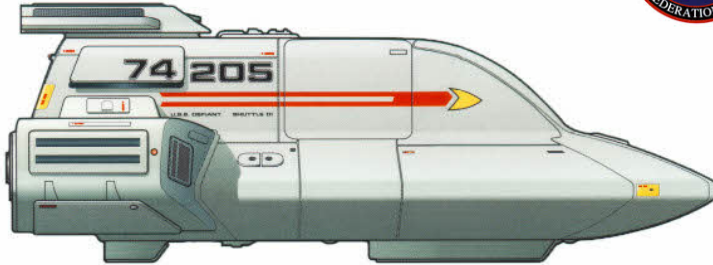

Class: Type-18
Type: Shuttlepod
Commissioned: 2371
Production Base: Antares Fleet Yards, Antares IV
Length: 4.5 metres
Beam: 3.1 metres
Height: 1.8 metres

Mass: 1.12 metric tons
Crew: 2 (plus 4 passengers)
Cruising Speed: Sublight
Maximum Speed: 0.2 c
Armament: 2 Type V phaser emitters

NCC 74205/01
Known Ships (Name unknown)

CLASS INFORMATION:

Like its bigger brother, the *Type-10* shuttle, the *Type-18* shuttlepod was developed alongside, and for use aboard, the *Defiant*-class escort. Compared to the *Type-15* and *Type-16* shuttlepods, the *Type-18* is designed to handle more vigorous assignments and function in battle situations.

The *Type-18* is suitable for a variety of roles, including starship escape, planetary surface operations, and ship-to-ship transfers. The craft is equipped with limited phaser armaments, but can be modified to mount a number of small weapons systems. Like the *Type-10*, the *Type-18* features truncated, armoured nacelle pods.

Defiant-class starships can carry up to four *Type-18* shuttlepods.



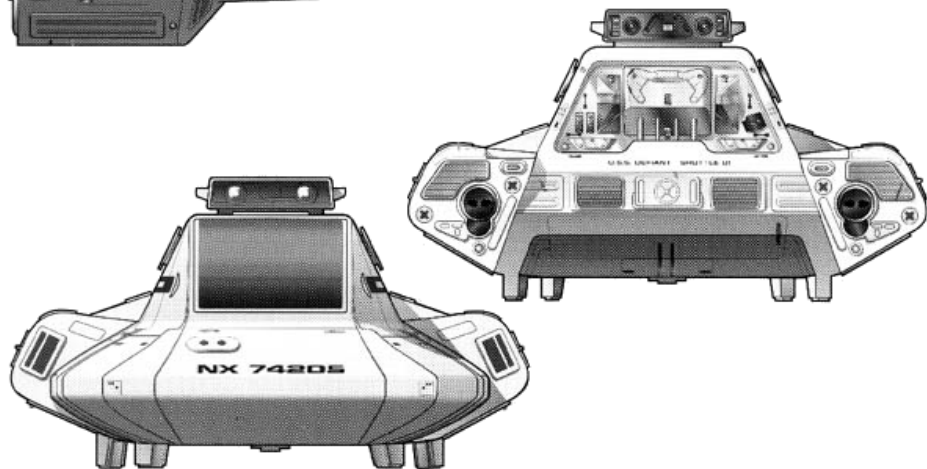
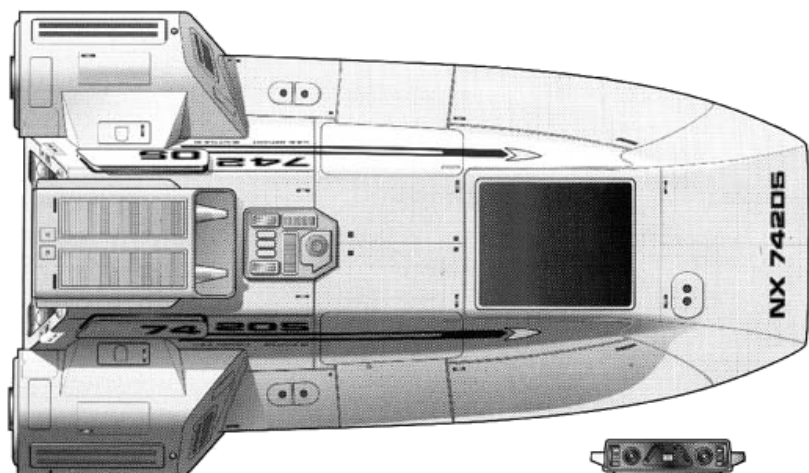
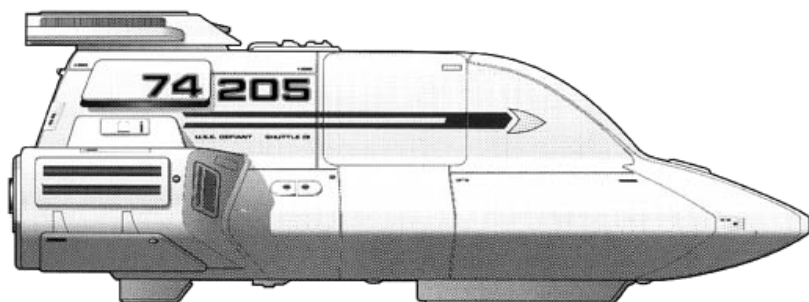

WORK BEE



Class: Work Bee
Type: General Utility Craft
Commissioned: 2268
Production Base: Various
Length: 1.2 metres
Beam: 1.2 metres
Height: 1.3 metres
Mass: 2.23 metric tons

Crew: 1
Cruising Speed: 7.9 km/s
Maximum Speed: 8.2 km/s
Armament: None

Known Ships
005
008
010
342

CLASS INFORMATION:

A *Work Bee* is a small, versatile, microfusion-powered utility craft designed to support the construction and maintenance of starships and space stations.

The *Work Bee* consists of a cab for a single operator, which can be fitted with a variety of specialised add-on modules, including a grabber sled, a welder unit, a 'metal spinner' unit, and cargo or passenger module trains, amongst others. The forward hatch can be opened, allowing the pilot to leave the craft to conduct an EVA. The hatch can also be disconnected and removed for unpressurised work.

With upgrades and enhancements to the basic design, the versatile *Work Bee* has continued in service for over 110 years. *Work Bees* assisted in the refitting of the original *U.S.S. Enterprise NCC-1701* and the launch of the *Enterprise-B*, and were numerous at San Francisco Fleet Yards, Utopia Planitia, and Deep Space Nine.



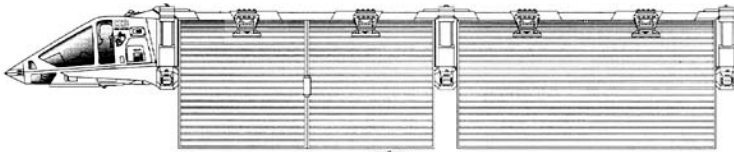
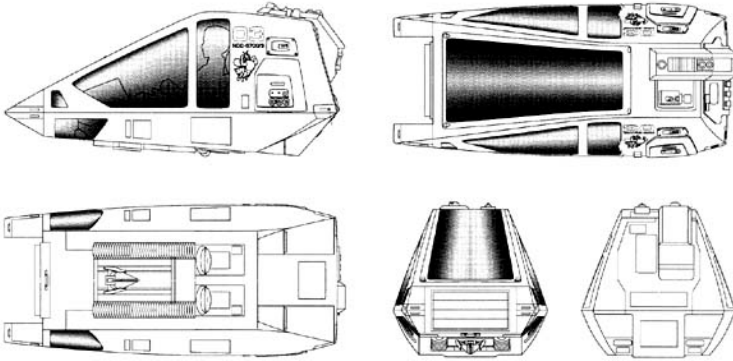

Cargo Train

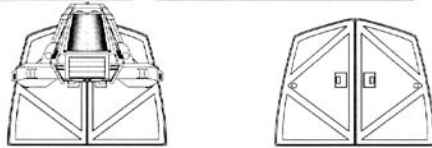

Bee Packs



Booster Pack

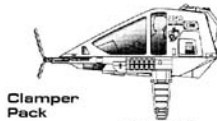

Clamper Pack



Cutter Pack



Heavy Booster Pack



Drone Pack



Floodlight Pack



Grabber Pack



Sensor Pack

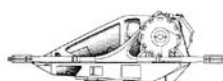

Spinner Pack



Survey Pack



Tractor Pack

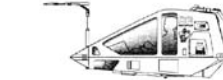

Welder Pack



SIZE COMPARISON CHARTS

MAJOR STARFLEET VESSELS

0 100m 200m 300m



Sovereign: 685m



Galaxy: 643m

Danube: 23m



Ambassador: 526m

Defiant: 120m



Excelsior: 467m

Oberth: 150m



Akira: 440m

Nova: 180m

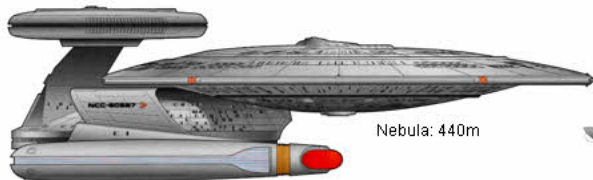

Nebula: 440m

Saber: 223m



Prometheus: 414m

NX: 225m



Steamrunner: 356m

Miranda: 243m



Intrepid: 344m

Constitution: 289m



Constitution II: 305m

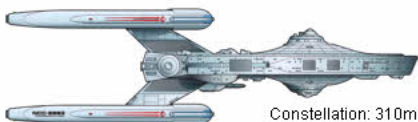

Constellation: 310m

OTHER STARFLEET VESSELS

0 100m 200m 300m



Niagara: 480m



Excelsior II: 469m



Freedom: 430m

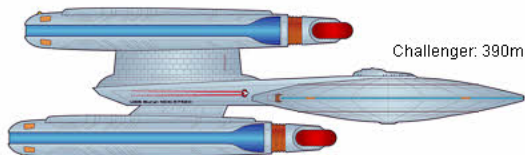

Challenger: 390m



Cheyenne: 362m



Norway: 355m



New Orleans: 340m



Springfield: 325m



Raven: 90m



Daedalus: 105m



Iceland: 120m



Sherman: 163m



NV: 170m



Centaur: 210m



Sydney: 235m



Saladin/Hermes: 242m

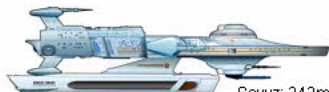

Soyuz: 243m



Curry: 272m

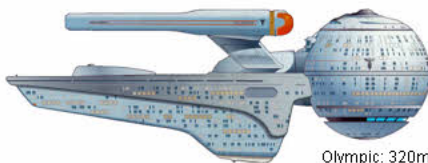

Olympic: 320m

ALPHA & BETA QUADRANTS

0 100m 200m 300m

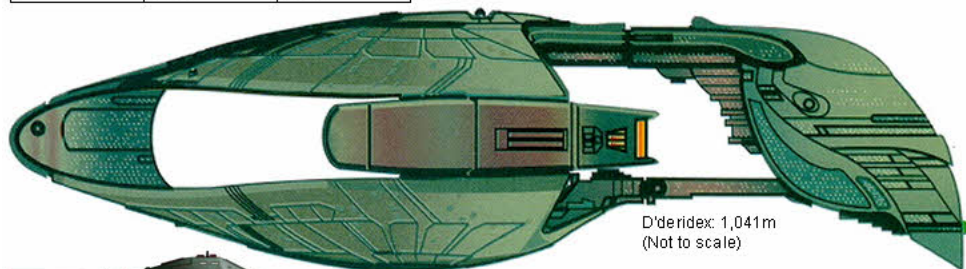

Tholian Ship: 15m

Kestrel: 24m

Romulan scout: 89m

Romulan science ship: 95m

Hideki: 98m

Klingon Bird-of-Prey: 110m

Romulan Bird-of-Prey: 131m

Merchantman: 150m

K't'inga: 214m

D-7: 228m

Cardassian military freighter: 256m

GAMMA & DELTA QUADRANTS

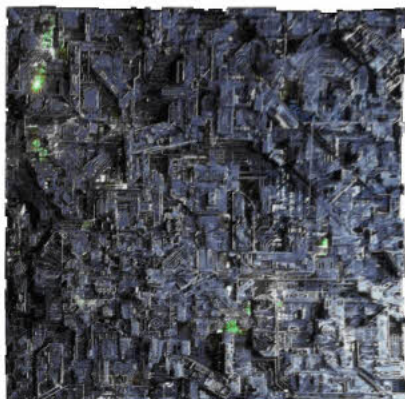

Borg Cube: 3040m



Borg Tactical Cube: 3040m

0 500m 1km



Borg Queen's Ship: 820m



Borg Sphere: 600m



Devore warship: 800m



Jem'Hadar Battleship: 1457m



Kazon Carrier: 1800m



Borg Type 03: 1200m

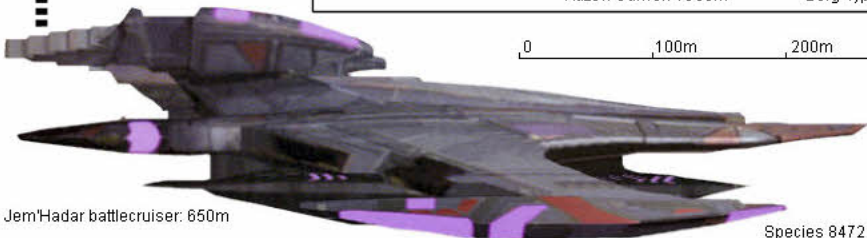

Jem'Hadar battlecruiser: 650m

0 100m 200m 300m



Malon export vessel: 515m



Krenim warship: 500m



Borg Probe: 360m



Species 8472 bioship: 50m



Jem'Hadar attack ship: 95m



Voth science ship: 130m



Vidlian Interceptor: 140m



Hirogen hunter ship: 150m



Kazon raider: 160m



Karemma ship: 380m

22nd CENTURY VESSELS

0 100m 200m 300m



Xindi-Aquatic Cruiser: 1,800m (Not to scale)



D'Kyr: 600m



Surak: 600m



Kumari: 360m



Y Class: 270m



J Class: 230m



Klingon D4: 205m

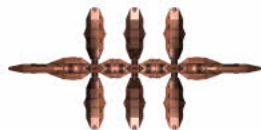

Suliban Salvage Ship: 190m



Romulan Early Bird-of-Prey: 165m



Stealth Cruiser: 106m



Vahklas: 110m



Klingon Early Bird-of-Prey: 115m



Insectoid Warship: 120m



Raptor: 145m



Klingon D5: 155m

0 10m 20m 30m



Long Cell Ship: 40m



Romulan Drone: 35m



Tholian Starship: 15m



Suliban Cell Ship: 2.6m

AUXILIARY VESSELS

0 5m 10m 15m 20m

Vulcan warpsuttle: 48m



Type 15: 3.6m



Type 18: 4.5m



Sovereign captain's yacht: 33.5m



NX class shuttlepod: 6m



Type 6: 6m



Type 10: 6.5m



Aeroshuttle: 27m



Galileo 7: 6.7m



Executive shuttle: 26m



Type 8: 7m

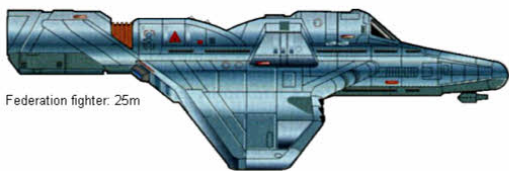

Federation fighter: 25m



Type 7: 8.5m



Type 9: 8.5m



Scout: 24m



Galileo 5: 9.1m



Enterprise-E shuttle: 16m



Delta Flyer: 21m



Argo jeep: 5m



Argo shuttle: 20m

SUPPLEMENTAL



Voth City Ship: 9,800m



Son'a Battleship: 837m



Hirogen Venatic: 600m



Vidlian Cruiser: 500m



Son'a command ship: 354m



Whorfin: 270m



Holoship: 247m



Ptolemy: 222m



Conestoga: 180m



TPau: 170m

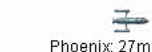

Phoenix: 27m



T'Plana Hath: 45m



Maquis raider: 60m



Tug: 66m



DY-100: 108m



NX prototype: 20m



Travel pod: 4.4m



Inspection pod: 3.3m



Work bee: 3.2m



BIBLIOGRAPHY

BIBLIOGRAPHY - 1

BOOKS, MAGAZINES & EBOOKS

- Decipher Starships Sourcebook* - by B.Bridges, A.Greenberg, K.Hite, R.Isaacs & D.Sun. Decipher Inc., 2003.
- Jackill's Star Fleet Reference Manual Vol.1* - by Eric Kristiansen. Jackill's, 1992.
- Mr. Scott's Guide to the Enterprise* - by Shane Johnson. Pocket Books, 1987.
- Starfleet Dynamics* - by David John Schmidt. 2000.
- The Making of Star Trek* - by Stephen E. Whitfield and Gene Roddenberry. Titan Books, 1991.
- Spacedock Ship Recognition Manual* - by Stephen S. Long. 2000.
- Star Fleet Technical Manual* - by Franz Joseph. Titan Books, 1975.
- Starship Recognition Manual (Beta)* - by Robert Hamilton III. 2007.
- Star Trek Concordance* - by Bjo Trimble. Titan Books, 1995.
- Star Trek Encyclopedia* - by Michael Okuda, Denise Okuda & Debbie Mirek. Pocket Books, 1997.
- Star Trek Fact Files* - GE Fabbri, 1997-2002
- Star Trek: The Magazine* - Titan Magazines, 1995-2010.
- Star Trek Ships of the Line* - by Michael Okuda, edited by Doug Drexler and Margaret Clark. Pocket Books, 2006.
- Star Trek Ships of the Line Calendar 2006* - edited by Doug Drexler. Andrews McMeel Publishing, 2005.
- Star Trek Star Charts* - by Geoffrey Mandel. Pocket Books, 2002.
- Star Trek: Starship Spotter* - by Adam 'Mojo' Lebowitz & Robert Bonchune. Pocket Books, 2001.
- ST:DS9 Technical Manual* - by Herman Zimmerman, Doug Drexler & Rick Sternbach. Pocket Books, 1998.
- ST:TNG Technical Manual* - by Rick Sternbach & Michael Okuda. Boxtree, 1991.

WEBSITES

- [Advanced Starship Design Bureau](#) - Star Trek starship PDFs by Chris Wallace and Team Nexus.
- [Daystrom Institute Technical Library](#) - the Star Trek reference site of Graham Kennedy.
- [Desktop Starships](#) - science fiction wallpaper.
- [Drex Files](#) - the blog of visual effects artist and illustrator Doug Drexler.
- [Eavesdropping with Johnny](#) - the blog of designer and illustrator John Eaves.
- [Ex Astris Scientia](#) - the Star Trek reference site and starship database of Bernd Schneider.
- [Gilso Star Trek Schematics](#) - blueprints and schematics by Gerard Gillan.
- [Joe's Enterprise Season 5 Development Blog](#) - the animation project and blog of Joe Hodkiss.
- [LCARS-Interface](#) - graphics and schematics by Tobias Weimann.
- [The Light Works](#) - the digital imagery and visual effects site of Tobias Richter.
- [Mateen's 3D Graphics](#) - the 3D graphics and modelling site of Mateen Greenway.
- [Memory Alpha](#) - the online encyclopedia and database of canon Star Trek.
- [Memory Beta](#) - the online encyclopedia and database of licensed Star Trek content.
- [Neutral Zone Starship Database](#) - the starship reference site of Thomas Schmid.
- [Obsidian Fleet](#) - play by email Star Trek roleplaying site.
- [Scifi-Meshes.com Forum](#) - online community for 3D science fiction.
- [Starship Schematic Database](#) - Jim Stevenson's collection and database of schematics and plans.
- [STARTREK.com](#) - CBS Entertainment's official website of Star Trek.
- [Star Trek: A Call to Duty](#) - online Star Trek roleplaying game.
- [Star Trek LCARS Blueprints Database](#) - John Patuto's collection of schematics and plans.
- [Star Trek Minutiae](#) - Star Trek reference site of Dan Carlson, featuring the logos of Kristian Trigwell.
- [ST Starship Tactical Combat Simulator Online Database](#) - the FASA reference site of Brad Torgersen.
- [Titan Fleet Yards](#) - the Star Trek and science fiction blog of Harry Doddema.
- [Trekmania](#) - the Star Trek and starship reference site of Mark George.
- [Trekplace](#) - the Star Trek reference site of Greg Tyler.

GAMES

Starfleet Command 3 & Star Trek Armada 2 - Activision, Star Trek Online - Cryptic Studios.

BIBLIOGRAPHY - 2

IMAGE SOURCES

Colour side-views from Ex Astris Scientia except *Xindi-Aquatic Cruiser* and *Sphere Builder Pod* by Animaniac. Emblems from Ex Astris Scientia and Star Trek Minutiae (Tholian & Breen by Kristian Trigwell). Tholian and Species 8472 emblems originally by Geoffrey Mandel. ECS Fortunate emblem from Okudagrams.com.

AERIE CLASS -

Page 8: L - Star Trek Fact Files, R - Neutral Zone.de, Page 9: Schematics - Tobias Weimann

AKIRA CLASS - *Designed by Alex Jaeger*

Page 10: L - Mark Thomson, R - Desktop Starships, Page 11: Schematics - Adam Heinbuch

AMBASSADOR CLASS - *Designed by Rick Sternbach*

Page 12: L - Neutral Zone.de, R - Desktop Starships Page 13: Schematics - Adam Heinbuch

ATLAS CLASS -

Page 14: L - Neutral Zone.de, R - Doug Drexler, Page 15: Schematics - Starship Schematic Database

CENTAUR CLASS - *Designed by Adam Buckner*

Page 16: L - Star Trek: The Magazine, R - Unknown, Page 17: Schematics - Flare Sci-Fi Forums

CHALLENGER CLASS - *Designed by Ed Miarecki*

Page 18: L - The Red Admiral, R - The Red Admiral, Page 19: Schematics - Copernicus Shipyards

CHEYENNE CLASS - *Designed by Greg Jein & Mike Okuda*

Page 20: L - The Red Admiral, The Red Admiral, Page 21: Schematics - Krenim

CONSTELLATION CLASS - *Designed by Rick Sternbach*

Page 22: L - Star Trek exhibition, R - Memory Alpha, Page 23: Schematics - Neutral Zone.de

CONSTITUTION CLASS - *Designed by Matt Jefferies*

Page 24: L - STARTREK.com, R - STARTREK.com, Page 25: Schematics - Ex Astris Scientia

CONSTITUTION REFIT - *Designed by Andrew Probert*

Page 26: L - Memory Alpha, R - Star Trek Mechanics, Page 27: Schematics - Adam Heinbuch

DAEDALUS CLASS - *Designed by Matt Jefferies*

Page 28: L - Star Trek Chronology, R - Star Trek Chronology, Page 29: Schematics - Star Trek Fact Files

DANUBE CLASS - *Designed by Rick Sternbach & Jim Martin*

Page 30: L - Star Trek: The Magazine, R - Memory Alpha, Page 31: Schematics - Neutral Zone.de

DEFIANT CLASS - *Designed by Jim Martin*

Page 32: L - Ex Astris Scientia, R - Ex Astris Scientia, Page 33: Schematics - Neutral Zone.de

EXCELSIOR CLASS - *Designed by Nilo Rodis & Bill George*

Page 34: L - Memory Alpha, R - Star Trek Mechanics, Page 35: Schematics - Neutral Zone.de

EXCELSIOR REFIT - *Designed by John Eaves*

Page 36: L - Memory Alpha, R - Star Trek Mechanics, Page 37: Schematics - Neutral Zone.de

FREEDOM CLASS - *Designed by Greg Jein & Mike Okuda*

Page 38: L - The Red Admiral, R - The Red Admiral, Page 39: Schematics - Star Trek Fact Files

GALAXY CLASS - *Designed by Andrew Probert*

Page 40: L - Star Trek Mechanics, R - Memory Alpha, Page 41: Schematics - Adam Heinbuch

HOLOSHIP - *Designed by John Eaves*

Page 42: L - Neutral Zone.de, R - Neutral Zone.de, Page 43: Schematics - Starship Schematic Database

ICELAND CLASS - *Designed by John Eaves & Rob Bonchune*

Page 44: L - Rob Bonchune, R - Neutral Zone.de, Page 45: Schematics - Unknown

INTREPID CLASS - *Designed by Rick Sternbach*

Page 46: L - Star Trek: The Magazine, R - Ex Astris Scientia, Page 47: Schematics - Adam Heinbuch

MIRANDA CLASS - *Designed by Joe Jennings & Mike Minor*

Page 48: L - Memory Alpha, R - Memory Alpha, Page 49: Schematics - Adam Heinbuch

NEBULA CLASS - *Designed by Ed Miarecki*

Page 50: L - Neutral Zone.de, R - Star Trek Mechanics, Page 51: Schematics - Adam Heinbuch

NEW ORLEANS CLASS - *Designed by Ed Miarecki*

Page 52: L - The Red Admiral, R - Star Trek Encyclopedia, Page 53: Schematics - Starship Schematic Database

NIAGARA CLASS - *Designed by Greg Jein & Michael Okuda*

Page 54: L - The Red Admiral, R - The Red Admiral, Page 55: Schematics - Star Trek Fact Files

NORWAY CLASS - *Designed by Alex Jaeger*

Page 56: L - TNG Sketchbook: The Movies, R - The Red Admiral, Page 57: Schematics - Gilso Star Trek Schematics

NOVA CLASS - *Designed by Rick Sternbach*

Page 58: L - Star Trek: The Magazine, R - Neutral Zone.de, Page 59: Schematics - Adam Heinbuch

NV CLASS - *Designed by John Eaves & Rob Bonchune*

Page 60: L - Gotardo, R - Memory Alpha, Page 61: Schematics - Irishman

NX CLASS - *Designed by Herman Zimmerman*

Page 62: L - TV Guide, R - Memory Alpha, Page 63: Schematics - Unknown

NX PROTOTYPE - *Designed by John Eaves*

Page 64: L - DITL.org, R - DITL.org, Page 65: Schematics - Neutral Zone.de

OBERTH CLASS - *Designed by David Carson*

Page 66: L - The Art of Star Trek, R - Neutral Zone.de, Page 67: Schematics - Ex Astris Scientia

OLYMPIC CLASS - *Designed by Bill George*

Page 68: L - Unknown, R - Neutral Zone.de, Page 69: Schematics - Starship Schematic Database

BIBLIOGRAPHY - 4

ROMULAN MOGAI CLASS - *Designed by John Eaves*

Page 142: L - IGN, R - Neutral Zone.de,
Page 143: Schematics - Animaniac (edited by Fenix)

ROMULAN NEH'VOR CLASS -

Page 144: L - Star Trek Fact Files, R - Memory Alpha,
Page 145: Schematics - Star Trek Fact Files

ROMULAN TERETHI CLASS - *Designed by Rick Sternbach*

Page 146: L - Neutral Zone.de, R - Neutral Zone.de,
Page 147: Schematics - Starship Schematic Database

CARDASSIAN GALOR CLASS - *Designed by Rick Sternbach*

Page 150: L - Star Trek Fact Files, R - Neutral Zone.de,
Page 151: Schematics - Starship Schematic Database

CARDASSIAN GROUMALL CLASS - *Designed by John Eaves*

Page 152: L - Neutral Zone.de, R - Neutral Zone.de,
Page 153: Schematics - Star Trek Fact Files

CARDASSIAN HIDEKI CLASS - *Designed by Rick Sternbach*

Page 154: L - Neutral Zone.de, R - Memory Alpha,
Page 155: Schematics - Star Trek Fact Files

CARDASSIAN KELDON CLASS - *Designed by Tony Meininger*

Page 156: L - STTNG: The Continuing Mission, R - Memory Alpha,
Page 157: Schematics - Starship Schematic Database

FERENGI D'KORA CLASS - *Designed by Andrew Probert*

Page 160: L - Neutral Zone.de, R - Neutral Zone.de,
Page 161: Schematics - Adam Heinbuch

THOLIAN PATROL SHIP -

Page 164: L - StarTrek.com, R - Memory Alpha,
Page 165: Schematics - Starship Schematic Database

THOLIAN STARSHIP - *Designed by John Eaves*

Page 166: L - Neutral Zone.de, R - Memory Alpha,
Page 167: Schematics - Animaniac

JEM'HADAR ATTACK SHIP - *Designed by Jim Martin*

Page 170: L - Star Trek Mechanics, R - Star Trek Fact Files,
Page 171: Schematics - Starship Schematic Database

JEM'HADAR BATTLECRUISER - *Designed by John Eaves*

Page 172: L - Neutral Zone.de, R - Neutral Zone.de,
Page 173: Schematics - Adam Heinbuch

JEM'HADAR BATTLESHIP - *Designed by John Eaves*

Page 174: L - Neutral Zone.de, R - Memory Alpha,
Page 175: Schematics - Adam Heinbuch

BREEN WARSHIP - *Designed by John Eaves*

Page 176: L - Neutral Zone.de, R - Ex Astris Scientia,
Page 177: Schematics - Adam Heinbuch

KAREMMA TRADING VESSEL -

Page 178: L - Star Trek Fact Files, R - Neutral Zone.de,
Page 179: Schematics - Starship Schematic Database

SON'A BATTLESHIP - *Designed by John Eaves*

Page 180: L - DITL.org, R - Memory Alpha,
Page 181: Schematics - Neutral Zone.de

SON'A COMMAND SHIP - *Designed by John Eaves*

Page 182: L - DITL.org, R - Neutral Zone.de,
Page 183: Schematics - Star Trek Fact Files

BORG CUBE - *Designed by Maurice Hurley & Rick Sternbach*

Page 186: L - Neutral Zone.de, R - Neutral Zone.de,
Page 187: Schematics - Starship Schematic Database

BORG QUEEN'S SHIP -

Page 188: L - Neutral Zone.de, R - Star Trek Fact Files,
Page 189: Schematics - Starship Schematic Database

BORG PROBE -

Page 190: L - Neutral Zone.de, R - Star Trek Fact Files,
Page 191: Schematics - Starship Schematic Database

BORG SPHERE -

Page 192: L - Neutral Zone.de, R - Neutral Zone.de,
Page 193: Schematics - Starship Schematic Database

BORG TACTICAL CUBE - *Designed by Doug Drexler*

Page 194: L - Neutral Zone.de, R - Star Trek: The Magazine,
Page 195: Schematics - STSTCS Online Database

BORG TYPE 03 - *Designed by Dan Curry*

Page 196: L - Neutral Zone.de, R - Neutral Zone.de,
Page 197: Schematics - Starship Schematic Database

VULCAN APOLLO CLASS -

Page 200: L - ST:TNG Continuing Mission, R - Neutral Zone.de,
Page 201: Schematics - Star Trek Fact Files

VULCAN D'KYR CLASS - *Designed by John Eaves*

Page 202: L - Ex Astris Scientia, R - Neutral Zone.de,
Page 203: Schematics - Joe Hodkiss

VULCAN SUUROK CLASS - *Designed by Doug Drexler*

Page 204: L - Ex Astris Scientia, R - Memory Alpha,
Page 205: Schematics - Neutral Zone.de

VULCAN T'PLANA HATH CLASS - *Designed by John Eaves*

Page 206: L - Memory Alpha, R - Neutral Zone.de,
Page 207: Schematics - Starship Schematic Database

VULCAN VAHKLAS CLASS -

Page 208: L - Ex Astris Scientia, R - Ex Astris Scientia,
Page 209: Schematics - Doug Drexler

ANDORIAN KUMARI CLASS -

Page 212: L - Rob Bonchune, R - Memory Alpha,
Page 213: Schematics - Joe Hodkiss

SULIBAN CELL SHIP (SHORT) - *Designed by John Eaves*

Page 216: L - Neutral Zone.de, R - DITL.org,
Page 217: Schematics - Doug Drexler

SULIBAN CELL SHIP (LONG) - *Designed by John Eaves*

Page 218: L - Neutral Zone.de, R - DITL.org,
Page 219: Schematics - Doug Drexler

SULIBAN SALVAGE SHIP - *Designed by John Eaves*

Page 220: L - Memory Alpha, R - DITL.org,
Page 221: Schematics - Doug Drexler

BIBLIOGRAPHY - 5

SULIBAN STEALTH CRUISER - *Designed by John Eaves*
Page 222: L - Neutral Zone.de, R - Neutral Zone.de,
Page 223: Schematics - Doug Drexler

XINDI-AQUATIC CRUISER -

Page 226: L - Neutral Zone.de, R - Memory Alpha,
Page 227: Schematics - Animaniac

XINDI-INSECTOID WARSHIP - *Designed by John Eaves*

Page 228: L - Ex Astris Scientia, R - Jörg Hillebrand,
Page 229: Schematics - John Eaves

SPHERE BUILDER POD -

Page 230: L - Neutral Zone.de, R - DITL.org,
Page 231: Schematics - Animaniac

DEVORE WARSHIP -

Page 234: L - Gilso Star Trek Schematics, R - Neutral Zone.de,
Page 235: Schematics - Janet's Star Trek Voyager Site

HIROGEN HUNTER SHIP -

Page 236: L - Memory Alpha, R - Star Trek Fact Files,
Page 237: Schematics - Starship Schematic Database

HIROGEN VENATIC CLASS - *Designed by Rick Sternbach*

Page 238: L - Neutral Zone.de, R - Star Trek Fact Files,
Page 239: Schematics - Doug Drexler

KAZON CARRIER -

Page 240: L - Neutral Zone.de, R - Memory Alpha,
Page 241: Schematics - Ex Astris Scientia

KAZON RAIDER -

Page 242: L - Ex Astris Scientia, R - Memory Alpha,
Page 243: Schematics - Star Trek Fact Files

KRENIM WARSHIP -

Page 244: L - Star Trek Fact Files, R - Memory Alpha,
Page 245: Schematics - Starship Schematic Database

MALON EXPORT VESSEL -

Page 246: L - Ex Astris Scientia, R - Neutral Zone.de,
Page 247: Schematics - Starship Schematic Database

SPECIES 8472 BIOSHIP -

Page 248: L - Neutral Zone.de, R - Neutral Zone.de,
Page 249: Schematics - Starship Schematic Database

VIDIAN CRUISER - *Designed by Rick Sternbach*

Page 250: L - Neutral Zone.de, R - Memory Alpha,
Page 251: Schematics - Doug Drexler

VIDIAN INTERCEPTOR -

Page 252: L - Neutral Zone.de, R - Memory Alpha,
Page 253: Schematics - Starship Schematic Database

VOTH CITY SHIP -

Page 254: L - Ex Astris Scientia, R - Memory Alpha,
Page 255: Schematics - Starship Schematic Database

VOTH RESEARCH VESSEL -

Page 256: L - Neutral Zone.de, R - Star Trek Fact Files,
Page 257: Schematics - Starship Schematic Database

AEROSHUTTLE - *Designed by Rick Sternbach & Rob Bonchune*

Page 260: L - Memory Alpha, R - Star Trek Fact Files,
Page 261: Schematics - Starship Schematic Database

ARGO CARGO SHUTTLE - *Designed by John Eaves*

Page 262: L - Neutral Zone.de, R - Memory Alpha
Page 263: Schematics - LCARS-Interface/Lobo/Alex Hartmann

ATAI LONG-RANGE SHUTTLE - *Designed by Andrew Probert*

Page 264: L - Star Trek Fact Files, R - Memory Alpha,
Page 265: Schematics - Starship Schematic Database

CLASS-F SHUTTLE - *Designed by T. Kellogg & M. Jefferies*

Page 266: L - Ex Astris Scientia, R - Memory Alpha,
Page 267: Schematics - Starship Schematic Database

DELTA FLYER - *Designed by Richard James & Rick Sternbach*

Page 268: L - Star Trek Fact Files, R - Memory Alpha,
Page 269: Schematics - Adam Heinbuch

EXECUTIVE SHUTTLE - *Designed by John Goodson*

Page 270: L - Star Trek: The Continuing Mission, R - Memo-
ry Alpha, Page 271: Schematics - Star Trek Fact Files

INSPECTION POD - *Designed by John Eaves*

Page 272: L - Memory Alpha, R - Neutral Zone.de,
Page 273: Schematics - Ex Astris Scientia

MISSION SCOUT SHIP - *Designed by John Eaves*

Page 274: L - Neutral Zone.de, R - Unknown,
Page 275: Schematics - Star Trek Fact Files

PEREGRINE CLASS FIGHTER -

Page 276: L - Memory Alpha, R - Memory Alpha,
Page 277: Schematics - Adam Heinbuch

SOVEREIGN CAPTAIN'S YACHT - *Designed by John Eaves*

Page 278: L - The Light Works, R - Neutral Zone.de.
Page 279: Schematics - Star Trek Fact Files

TRAVEL POD - *Designed by Andrew Probert*

Page 280: L - The Art of Star Trek, R - DITL.org,
Page 281: Schematics - Starship Schematic Database

TYPE-1 SHUTTLEPOD - *Designed by John Eaves*

Page 282: L - Neutral Zone.de, R - LCARS-Interface,
Page 283: Schematics - Ex Astris Scientia

TYPE-3 SHUTTLE - *Designed by N.Rodis & A.Neskoromny*

Page 284: L - Memory Alpha, R - Memory Alpha,
Page 285: Schematics - Starship Schematic Database

TYPE-6 SHUTTLECRAFT - *Designed by Rick Sternbach*

Page 286: L - Neutral Zone.de, R - Neutral Zone.de,
Page 287: Schematics - Starship Schematic Database

TYPE-7 SHUTTLECRAFT - *Designed by Andrew Probert*

Page 288: L - Neutral Zone.de, R - Neutral Zone.de,
Page 289: Schematics - Starship Schematic Database

TYPE-8 SHUTTLECRAFT -

Page 290: L - Ex Astris Scientia, R - DITL.org,
Page 291: Schematics - Starship Schematic Database

TYPE-9 SHUTTLECRAFT - *Designed by Rob Bonchune*

Page 292: L - Ex Astris Scientia, R - Memory Alpha,
Page 293: Schematics - Star Trek Fact Files

BIBLIOGRAPHY - 6

TYPE-10 SHUTTLECRAFT - *Designed by Doug Drexler*

Page 294: L - Gilso Star Trek Schematics, R - Neutral Zone.de, Page 295: Schematics - ST:DS9 Technical Manual

TYPE-11 SHUTTLECRAFT - *Designed by*

Page 296: L - Neutral Zone.de, R - Neutral Zone.de,

Page 297: Schematics - Starship Schematic Database

TYPE-15 SH'POD - *Designed by R.Sternbach & R.McKenzie*

Page 298: L - Neutral Zone.de, R - Neutral Zone.de,

Page 299: Schematics - Starship Schematic Database

TYPE-18 SHUTTLEPOD -

Page 300: L - Neutral Zone.de, R - Neutral Zone.de,

Page 301: Schematics - Star Trek Fact Files

WORK BEE - *Designed by Andrew Probert*

Page 302: L - Doug Drexler, R - Memory Alpha,

Page 303: Schematics - Starship Schematic Database

SIZE COMPARISON CHARTS - Pages 306-312:

Adapted from the Fleet Charts of Bernd Schneider (Ex Astris Scientia).

Created with Serif PagePlus software. This ebook was produced purely for reference and fun, on a non-profit, not-for-sale basis. All copyrights are acknowledged and no infringement is intended. Star Trek and all photos, symbols and designs copyright Paramount Pictures and CBS Studios Inc. as far as I am aware.

This document © Mark Gill 2004-2014



trek.escape-committee.co.uk